

# *Satellite Titan WUXGA 120Hz*

Digital Video Projector

INSTALLATION & QUICK START GUIDE

CONNECTION GUIDE

ON SCREEN DISPLAY (OSD) OPERATING GUIDE

REFERENCE GUIDE



A brand of  **DELTA**

## Introduction

Congratulations on your purchase of this Digital Projection product. The Satellite Titan WUXGA 120Hz has the following key features:

- Satellite Modular Laser System
- Offers separation of Head from the light source for reduced size, weight and noise compared to a conventional projector.
- WUXGA native resolution delivering up to 30,000 ISO lumens.
- RGB laser illuminated
- Supports a combination of Modular Light Source modules including MLS 10000, MLS 20000 and MLS 30000.
- Satellite Link Cable enables light source MLS modules to be remote
- Wide color gamut very close to REC2020
- DisplayPort and HDMI Inputs
- Control via LAN
- Motorised and memorized lens mount with shift, zoom and focus using compatible lenses.

A serial number is located on the side of each Satellite module. Please record it here for future reference:

Follow the instructions in this manual carefully to ensure safe and long-lasting use of the projection system. Do not attempt to power the system on or operate the projector until the system has been safely installed. Please refer to the Installation and Quick Start Guide later in this manual for full installation details.

### Notes



*This product is a Laser Risk Group 3 product.*

## About this document

### Symbols used in this document

Many pages in this document have a dedicated area for notes. The information in that area is accompanied by the following symbols:



**LASER WARNING:** this symbol indicates that there is a potential hazard of eye exposure to laser radiation unless the instructions are closely followed.



**LIGHT HAZARD WARNING:** this symbol indicates that there is a danger of exposure to intensive light that may result in personal injury unless the instructions are closely followed.



**ELECTRICAL WARNING:** this symbol indicates that there is a danger of electrical shock unless the instructions are closely followed.



**WARNING:** this symbol indicates that there is a danger of physical injury to yourself and/or damage to the equipment unless the instructions are closely followed.



**NOTE:** this symbol indicates that there is some important information that you should read.

### Product revision

Because we at Digital Projection continually strive to improve our products, we may change specifications and designs, and add new features without prior notice.

### Additional Documentation

Updates to this manual may be available online.

Please use the QR code (also located on the satellite projector head, modular light source and satellite control module) to access the latest Satellite system user guides and other documentation via the Digital Projection website.

Or visit the Digital Projection website to download the latest user guide and other documentation. [www.digitalprojection.co.uk/digital-products/manuals/satellite/](http://www.digitalprojection.co.uk/digital-products/manuals/satellite/)



### Legal notice

Trademarks and trade names mentioned in this document remain the property of their respective owners. Digital Projection disclaims any proprietary interest in trademarks and trade names other than its own.

Copyright © 2024 Digital Projection Ltd. All rights reserved.

### Third Party Credits

DMD™, Digital Micromirror Device™ and DLP™ are trademarks of Texas Instruments Inc.

Art-Net™ Designed by and Copyright Artistic License Holdings Ltd.

etherCON™ Designed by and Copyright Neutrik AG.

### Notes

## Electrical and Physical Specifications

### Notes

### Satellite Head

Mains Voltage	100-240 VAC 50/60Hz single phase
Current	3.7 A at 100-240 VAC
Operating Temperature	0°C to 40°C (32°F to 104°F)
Storage Temperature	-20°C to 60°C (-4°F to 140°F)
Operating Humidity	20% to 80% non-condensing
Storage Humidity	20% to 90% non-condensing
Dimensions	450 mm x 494 mm x 340 mm
Weight	34.5 kg (excluding lens)
Power Consumption	at 100 VAC: typical 189.0 W, max 198.5 W at 100 VAC: typical 314.0 W, max 329.7 W (High Altitude Mode) at 240 VAC: typical 187.0 W, max 196.4 W at 240 VAC: typical 303.0 W, max 318.2 W (High Altitude Mode)
Thermal Dissipation	at 100 VAC: typical 2078 BTU/hr, max 2162 BTU/hr (Room Temperature)  at 100 VAC: typical 2505 BTU/hr, max 2610 BTU/hr (HighTemperature) (High Altitude Mode) at 240 VAC: typical 2072 BTU/hr, max 2155 BTU/hr (Room Temperature)  at 240 VAC: typical 2467 BTU/hr, max 2570 BTU/hr (HighTemperature) (High Altitude Mode)
Fan Noise	<32 dBA (1 MLS), <37 dBA (2 MLS), < 42 dBA (3 MLS)

## Modular Light Source

Multiple MLS are available for this system.

### **MLS 10000**

Mains Voltage	100-240 VAC 50/60Hz single phase
Current	10.1 A at 100 VAC 4.9 A at 240 VAC
Operating Temperature	0°C to 40°C (32°F to 104°F)
Storage Temperature	-10°C to 50°C (14°F to 122°F)
Operating Humidity	20% to 80% non-condensing
Storage Humidity	20% to 90%
Dimensions	19" 3U rack unit - 483mm (w) x 133mm (h) x 500mm (d)
Weight	16.5 kg
Power Consumption	at 100 VAC: typical 908.7 W, max 1004.6 W at 240 VAC: typical 872.4 W, max 963.4 W
Thermal Dissipation	at 100 VAC: typical 2623 BTU/hr, max 2950 BTU/hr at 240 VAC: typical 2499 BTU/hr, max 2809 BTU/hr
Fan Noise	< 45 dBA
Fuse in Fuse Holder	marking T15AH/250 VAC, or F15AH/250 VAC

### **MLS 20000**

Mains Voltage	100-240 VAC 50/60Hz single phase
Current	5.5 A at 100 VAC 10.5 A at 240 VAC
Operating Temperature	0°C to 40°C (32°F to 104°F)
Storage Temperature	-20°C to 60°C (-4°F to 140°F)
Operating Humidity	20% to 80% non-condensing
Storage Humidity	20% to 90%
Dimensions	19" 4U rack unit - 483mm (w) x 178mm (h) x 725mm (d)
Weight	28 kg
Power Consumption	at 100 VAC: typical 438 W, max 482 W at 240 VAC: typical 1633 W, max 1983 W
Thermal Dissipation	at 100 VAC: typical 1495 BTU/hr, max 1645 BTU/hr at 240 VAC: typical 5572 BTU/hr, max 6128 BTU/hr
Fan Noise	< 56 dB (A)

## Notes

**MLS 30000**

Mains Voltage	100-240 VAC 50/60Hz single phase
Current	6.5 A at 100 VAC 14.5 A at 240 VAC
Operating Temperature	0°C to 40°C (32°F to 104°F)
Storage Temperature	-20°C to 60°C (-4°F to 140°F)
Operating Humidity	20% to 80% non-condensing
Storage Humidity	20% to 90%
Dimensions	19" 4U rack unit - 483mm (w) x 178mm (h) x 725mm (d)
Weight	29 kg
Power Consumption	at 100 VAC: typical 559 W, max 615 W at 240 VAC: typical 2488 W, max 2834 W
Thermal Dissipation	at 100 VAC: typical 1907 BTU/hr, max 2098 BTU/hr at 240 VAC: typical 8489 BTU/hr, max 9339 BTU/hr
Fan Noise	< 60 dB (A)

**Satellite Control Module**

Mains Voltage	100-240 VAC 50/60Hz single phase
Current	0.4 A at 100-240 VAC
Operating Temperature	0°C to 40°C (32°F to 104°F)
Storage Temperature	-10°C to 50°C (14°F to 122°F)
Operating Humidity	20% to 80% non-condensing
Storage Humidity	20% to 90%
Dimensions	19" 3U rack unit - 483 mm (w) x 133 mm (h) x 265 mm (d)
Weight	6.5 kg
Power Consumption	at 100 VAC: typical 23.9 W, max 25.1 W at 240 VAC: typical 21.3 W, max 22.5
Thermal Dissipation	at 100 VAC: typical 82 BTU/hr, max 86 BTU/hr at 240 VAC: typical 73 BTU/hr, max 77 BTU/hr
Fan Noise	< 32 dBA
Fuse in Fuse Holder	marking T10AH/250 VAC

**Satellite Link Cable**

Operating Temperature	10°C to 40°C (50°F to 104°F)
Storage Temperature	-10°C to 50°C (14°F to 122°F)
Operating Humidity	20% to 80% non-condensing

 Specifications are subject to change without notice.

**Notes**

## Laser Parameters

	MLS 10000	MLS 20000	MLS 30000
Wavelength (Red)	635-647nm		
Wavelength (Blue)	459-471nm		
Wavelength (Green)	519-531nm		
Mode of operation	CW		
Total internal power	192 W	448 W	601 W

## Light Output

The light output for your Satellite system is the sum total of lumens produced by the Modular Light Sources (MLS) installed:

MLS	Light output (klm)
MLS 10000	10 klm
MLS 20000	20 klm
MLS 30000	30 klm

For example; a system with one MLS 10000 will produce a total light output of 10 klm. A system with one MLS 10000 and one MLS 20000 will produce a total light output of 30 klm:

The light output at each Satellite head is the total light output divided by the number of Satellite heads in the system:

Total Light Output (klm)	Number of Satellite Heads	Light Output (klm) at each Satellite Head
10 klm	1	10 klm
	2	5 klm
	3	3.3 klm
	4	2.5 klm
20 klm	1	20 klm
	2	10 klm
30 klm	1	30 klm
	2	15 klm

For example; a system with one MLS 10000 and 2 Satellite heads will produce a total light output of 10 klm, but 5 klm at each Satellite Head. A system with two MLS 10000 and 1 Satellite head will produce a total light output of 20 klm at the Satellite Head.

Use the light output at the Satellite Head to determine the hazard distance when installing the Satellite Head. See Risk Group 3 Laser Hazard Installation Precautions on page 37.

## Notes



*The maximum light output permitted for this Satellite Head is 30,000 klm.*

### Laser Power

The laser power for this projector is related to the fitted lens and the light output at the Satellite Heads:

Light output (klm) at each Satellite Head	Maximum Laser Power at Lens (mW)										
	0.37 : 1	0.65 - 0.85: 1	0.67 : 1	0.8 - 1.16 : 1	1.12 : 1	1.16 - 1.49:1	1.39 - 1.87:1	1.87 - 2.56:1	2.56 - 4.16:1	4.16 - 6.96:1	6.92 - 10.36:1
2.5 klm	6	20	20	30	30	40	55	70	160	400	1100
3.3 klm	6	30	28	35	33	60	65	100	200	750	1650
5 klm	6	32	22	42	87	80	88	135	366	950	2150
10 klm	8	40	17	55	36	130	140	240	684	1663	3300
15 klm	9	50	23	65	45	175	200	400	1000	2600	5500
20 klm	12	70	32.7	86	54	245	276	505	1366	3331	6800
30 klm	15	120	49	140	129	312	353	612	2050	4982	9404

**Notes**

## Compliance with International Standards



### RF Interference

FCC

The Federal Communications Commission does not allow any modifications or changes to the unit EXCEPT those specified by Digital Projection in this manual. Failure to comply with this government regulation could void your right to operate this equipment.

This equipment has been tested and found to comply with the limits for a Class B digital device, pursuant with Part 15 of the FCC Rules. These limits are designed to provide reasonable protection against harmful interference when the equipment is operated in a commercial environment. This equipment generates, uses, and can radiate radio frequency energy and, if not installed and used in accordance with the instruction manual, may cause harmful interference to radio communications. Operation of this equipment in a residential area may cause harmful interference, in which case the user will be responsible for correcting any interference.

### Noise

GSGV Acoustic Noise Information Ordinance

The sound pressure level for the Satellite Laser Head is less than 42 dB (A) according to ISO 3744 or ISO 7779.

The sound pressure level for the Modular Light Source (MLS 10000) is less than 45 dB (A) according to ISO 3744 or ISO 7779.

The sound pressure level for the Modular Light Source (MLS 20000) is less than 54 dB (A) dB (A) according to ISO 3744 or ISO 7779.

The sound pressure level for the Modular Light Source (MLS 30000) is less than 58 dB (A) dB (A) according to ISO 3744 or ISO 7779.

The sound pressure level for the Satellite Control Module is less than 32 dB (A) according to ISO 3744 or ISO 7779.

### European Waste Electrical and Electronic Equipment (WEEE) Directive



Digital Projection Ltd is fully committed to minimizing Waste Electrical and Electronic Equipment. Our products are designed with reuse, recycling and recovery of all components in mind. To this end, at end of life, your projector may be returned to Digital Projection Ltd or its agent so that the environmental impact can be minimized.

**Notes**

<b>Contents</b>	
<b>Introduction</b> .....	<b>2</b>
<b>About this document</b> .....	<b>3</b>
<i>Symbols used in this document</i> .....	3
<i>Product revision</i> .....	3
<i>Additional Documentation</i> .....	3
<i>Legal notice</i> .....	3
<i>Third Party Credits</i> .....	3
<b>Electrical and Physical Specifications</b> .....	<b>4</b>
<i>Satellite Head</i> .....	4
<i>Modular Light Source</i> .....	5
<i>Satellite Control Module</i> .....	6
<i>Satellite Link Cable</i> .....	6
<i>Laser Parameters</i> .....	7
<i>Light Output</i> .....	7
<i>Laser Power</i> .....	8
<b>Compliance with International Standards</b> .....	<b>9</b>
<i>RF Interference</i> .....	9
<i>Noise</i> .....	9
<i>European Waste Electrical and Electronic Equipment (WEEE) Directive</i> .....	9
<b>Contents</b> .....	<b>10</b>
<b>Installation &amp; Quick Start Guide</b> .....	<b>15</b>
<b>General Precautions</b> .....	<b>16</b>
<b>What's in the box?</b> .....	<b>18</b>
<i>Satellite Head</i> .....	18
<i>Modular Light Source - MLS10000 (Shipped Separately)</i> .....	19
<i>Modular Light Source - MLS20000, MLS30000 (Shipped Separately)</i> .....	19
<i>Satellite Control Module (Shipped Separately)</i> .....	20
<i>Satellite Link Cable (Shipped Separately)</i> .....	21
<b>Module Overviews</b> .....	<b>22</b>
<i>Satellite Head</i> .....	22
<i>Modular Light Source</i> .....	23
<i>MLS 10000</i> .....	23
<i>MLS 20000 / MLS 30000</i> .....	24
<i>Satellite Control Module</i> .....	25
<i>Location of Laser Aperture</i> .....	25
<i>Interlock Switches</i> .....	26
<i>Satellite Head</i> .....	26
<i>Modular Light Source - MLS10000</i> .....	27
<i>Modular Light Source - MLS 20000/MLS 30000</i> .....	27
<i>Satellite Control Module</i> .....	28
<i>Satellite Link Cable</i> .....	28
<b>Installation Precautions</b> .....	<b>29</b>
<i>Risk Group 3 precautions:</i> .....	29
<i>For Installations within the United States:</i> .....	29
<i>Risk Group 3:</i> .....	29
<i>Satellite Head</i> .....	30
<i>Modular Light Source and Satellite Control Module</i> .....	33
<i>Rack Mounts</i> .....	33
<i>Free Standing</i> .....	33
<i>Satellite Link Cable</i> .....	34
<i>Handling Precautions</i> .....	35
<b>Laser Safety Precautions</b> .....	<b>36</b>
<i>Laser Risk Group 3 Precautions</i> .....	36
<b>Risk Group 3 Laser Hazard Installation Precautions</b> .....	<b>37</b>
<i>Laser Risk Group 3 Installation Precautions</i> .....	37
<i>Light Hazard Warning</i> .....	37
<i>Light Hazard Distance and Hazard Zone</i> .....	38
<i>Restriction Zone</i> .....	39
<b>Fitting a lens</b> .....	<b>40</b>
<i>Inserting a new lens</i> .....	40
<i>Removing the lens</i> .....	42
<i>Fitting a lens stabilizing bracket</i> .....	42
<b>Positioning the screen and Satellite Head</b> .....	<b>46</b>
<b>Mounting the rack mount modules</b> .....	<b>47</b>
<i>MLS 10000</i> .....	47
<i>MLS 20000/MLS 30000</i> .....	48
<i>SCM</i> .....	48
<b>Connecting the Satellite Link Cable</b> .....	<b>49</b>
<b>Connecting the Signal and LAN cables</b> .....	<b>52</b>

**Notes**

Single Satellite Head and Modular Light Source - 1:1 System ..... 55

Multiple Modular Light Sources - n:1 System ..... 56

Multiple Satellite Projector Heads - 1:n System ..... 58

**Power Supply ..... 60**

    AC Power Precautions ..... 60

    Connecting the power supply ..... 61

**Basic Operating Instructions ..... 63**

    Switching the system on ..... 63

    Switching the projector off ..... 63

    Emergency off ..... 63

    Interlock reset ..... 64

    Selecting an input signal ..... 64

    Selecting a test pattern ..... 64

    Adjusting the lens ..... 65

    Adjusting the image ..... 65

        Orientation ..... 65

        Picture ..... 65

**Laser color calibration ..... 66**

**Operating the system ..... 67**

    Satellite Head Control panel ..... 67

    Remote control ..... 69

    Infrared reception ..... 73

    Module indicators ..... 74

        Satellite Head ..... 74

        Modular Light Source ..... 77

            MLS 10000 ..... 77

            MLS 20000 / MLS 30000 ..... 77

        Satellite Control Module ..... 77

**Connection Guide ..... 79**

**Signal inputs ..... 80**

    Digital inputs and outputs ..... 80

    EDID on the DisplayPort, HDMI, and HDBaseT inputs ..... 81

    Using DisplayPort / HDMI / HDBaseT switchers with the projector ..... 81

**Control connections ..... 82**

    LAN connection examples ..... 83

**On Screen Display (OSD) Operating Guide ..... 85**

**Introduction to the OSD ..... 86**

    Opening the Menu ..... 86

    Opening a submenu ..... 86

    Exiting menus and closing the OSD ..... 87

    Inside a menu ..... 87

    Accessing sub menus ..... 88

    Executing commands ..... 88

    Editing projector settings ..... 89

        Using a slider to set a value ..... 89

        Editing numeric values ..... 90

**Using the projector ..... 91**

    Main Menu ..... 91

    Input ..... 91

        EDID Mode ..... 92

    Lens ..... 93

        Lens Memory ..... 93

    Image ..... 95

    Advanced ..... 96

    Color ..... 97

        Color Space ..... 97

        Color Mode ..... 98

            ColorMax ..... 98

            Manual Color Matching ..... 99

            Color matching parameters explained ..... 100

            Color Temperature ..... 101

            Gains and Lifts ..... 101

    Geometry ..... 102

        Aspect Ratio ..... 102

        Theaterscope setting ..... 103

    Digital Zoom ..... 104

    Overscan ..... 105

    Blanking ..... 106

    Setup ..... 107

    System Setting ..... 108

        Clock Adjust ..... 109

        PIC Mute ..... 109

        Screen Setting ..... 110

        Power Setting ..... 110

            Schedule Management ..... 111

        ColorMax Setting ..... 112

**Notes**

*Measured Data / Target Data* ..... 112

*Control Setting* .....113

*Hotkey Setting* ..... 114

*OSD Settings* .....114

*Web Served OSD* .....115

*Memory* ..... 115

*Network* ..... 116

*Network Setup* ..... 116

*Information* .....117

*Signal Format* .....117

*System Status* ..... 118

*Thermal Status* .....118

*Factory Reset* ..... 119

**MLS 10000 Touchscreen Operating Guide** ..... **121**

**Introduction to the MLS 10000 Touchscreen** ..... **122**

*Using the menus* ..... 122

*Main Menu* ..... 123

*Laser* ..... 123

*Setup* ..... 124

*OSD Settings* ..... 124

*Network* ..... 124

*Information* .....125

*System Status* ..... 125

*Thermal Status* .....126

*Factory Reset* ..... 126

**MLS 20000 / MLS 30000 LCM Screen Operating Guide** ..... **127**

**Introduction to the MLS 20000 / MLS 30000 LCM Screen** ..... **128**

*LCM Pages* ..... 128

*System Status* .....128

*System Information* .....129

*Network Information* ..... 129

*Thermal Information* ..... 129

*Error Page* ..... 129

**SCM Touchscreen Operating Guide** ..... **131**

**Introduction to the SCM Touchscreen** ..... **132**

**Using the menus** ..... **133**

*System Configuration* ..... 133

*Main Menu* ..... 133

*Laser Power* ..... 134

*Interlocks* ..... 134

*Network* ..... 134

*Information* .....135

*Network Information* ..... 135

*Software Information* ..... 135

*System Information* ..... 136

*Hardware Information* .....136

*Service Information* .....137

*Component menu* .....137

**Reference Guide** ..... **139**

**Appendix A: Product labels** ..... **140**

*Satellite Head* .....140

*Label Locations* ..... 142

*Modular Light Source* .....144

*MLS 10000 Label Locations* .....146

*MLS 20000/MLS 30000 Label Locations* ..... 147

*Satellite Control Module* .....148

*Label Locations* ..... 148

*Satellite Link Cable* ..... 149

*Label Locations* ..... 150

**Appendix B: Choosing a lens** ..... **151**

*Basic calculation* ..... 152

*Basic calculation example* ..... 153

*Full lens calculation* ..... 154

*Introducing TRC* .....154

*Calculating TRC* .....155

*TRC table* ..... 155

*Calculating the throw ratio with TRC* .....155

*Full lens calculation example* ..... 156

**Appendix C: Screen requirements** ..... **157**

*Fitting the image to the display* ..... 157

*Images displayed full width of 1920 pixels* .....157

*Images displayed with a height of 1200 pixels* .....157

*Images displayed full height of 1200 pixels* ..... 158

*Diagonal screen sizes* ..... 158

**Appendix D: Positioning the image** ..... **159**

**Appendix E: Aspect ratios explained ..... 161**

*Aspect ratios examples* .....161

        Source: 4:3 .....161

        Source: 16:9 .....162

        Source: 16:10 (native) ..... 162

    Aspect ratio example: TheatreScope ..... 163

**Appendix F: Supported signal input modes ..... 164**

    2D formats .....164

**Appendix G: Wiring details ..... 166**

    Signal inputs and outputs .....166

        HDMI ..... 166

        DisplayPort .....167

        HDBaseT input .....167

    Control connections .....168

        LAN .....168

        RS232 ..... 168

**Appendix H: Cleaning the SLC ..... 169**

**Appendix I: Memory scheme and memory items ..... 170**

    Satellite Head .....170

    MLS ..... 172

    SCM .....172

**Appendix J: Served web pages ..... 173**

**Appendix K: Glossary of terms ..... 175**

**Notes**

This page is intentionally left blank

# *Satellite Titan WUXGA 120Hz*

Digital Video Projector

INSTALLATION & QUICK START GUIDE



A brand of  **DELTA**

## General Precautions

Notes

 **Warning! Death or Serious Injury could occur if the following precautions are ignored**

 **Eye Hazard! Do not look directly into the lens when the light source is on. The high brightness can cause permanent eye damage**

 **Fire Hazard! Keep any combustible material away from hot surfaces and the projected beam. Ensure cables do not contact hot surfaces**

 **Shock Hazard! Use only authorized components, tools, accessories and replacement parts specified by the manufacturer**

 **Trip Hazard! Locate cables where they cannot be pulled, tripped over or damaged by persons or objects**

**Operate the product in the specified operating environment and conditions**

**Product should be powered off and disconnected from the mains before any service or maintenance operation**

**Keep body parts, hair, clothing and jewellery away from moving parts in the product.**

**Do not operate the product without a lens installed**

**Use a lens plug when installing or moving the product**

 **The system is never to be operated if a component is defective or the covers are damaged.**

 **No maintenance allowed by end user.**

**Do not open any of the modules. There are no user serviceable parts inside.**

**No service is allowed except by authorized personnel.**

 **Service personnel should use effective laser safety goggles during service operations.**

 **Use only the power cable provided.**

 **Ensure that the power outlet includes a Ground connection, as this equipment **MUST** be earthed.**

 **Take care to prevent small objects such as paper or wire from falling into the Satellite Head , MLS or SCM. If this does happen, switch off immediately, and have the objects removed by authorized service personnel.**

 **Do not expose the Satellite Head , MLS and SCM to rain or moisture, and do not place any liquids on top of the projector.**

**Unplug before cleaning, and use a damp, not wet, cloth.**

**Do not touch the power plug with wet hands.**

**Do not touch the power plug during a thunder storm.**

**Handle the power cable carefully and avoid sharp bends. Do not use a damaged power cable.**



**Do not touch the ventilation outlets, as they will become hot in use.**

**Do not cover or obstruct the ventilation outlets or inlets.**

**Do not cover the lens whilst the system is switched on. This could cause a fire.**

**Always allow the Satellite Head , MLS and SCM to cool for 5 minutes before disconnecting the power or moving the projector.**

**Never use strong detergents or solvents such as alcohol or thinners to clean the projector and lens.**

**Notes**

# What's in the box?

## Satellite Head

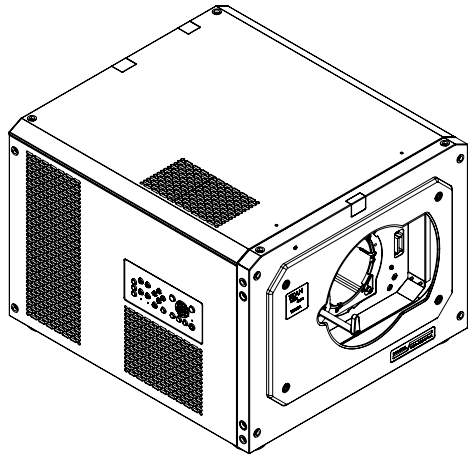

Satellite Head

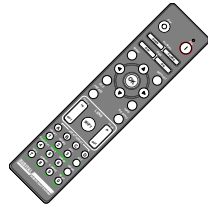

Remote Control

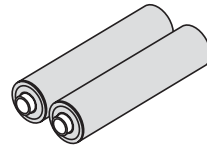

Batteries (2xAAA)

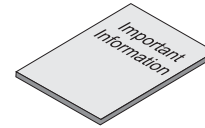

Important Information Book

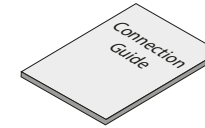

Connection Guide

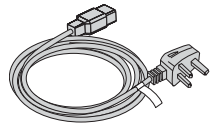

Power Cable, UK

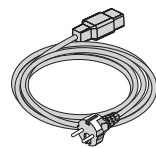

Power Cable, Europe

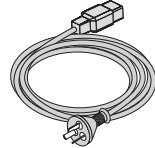

Power Cable, China

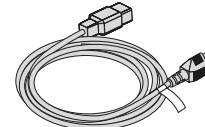







NEMA 5-15P - C19 Power Cable, North America



Lens Stabilizing Bracket with 2 x M4 Screws

### Notes

-  The MLS, SCM and SLC are shipped separately.
-  The appropriate MLS modules are supplied for your system.
-  The projector is shipped without a lens.
-  Make sure your box contains everything listed. If any pieces are missing, contact your dealer.
-  Only one remote is supplied with the projector.
-  Only the appropriate power cables for destination territory are supplied.
-  Save and store the original box and packing materials, in case you ever need to ship your projector.

**Modular Light Source - MLS10000 (Shipped Separately)**

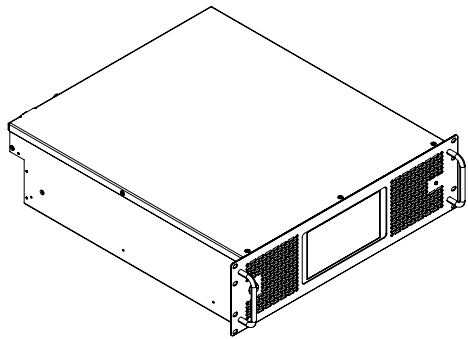

*Modular Light Source (MLS 10000)*



*Important Please Read Booklet*

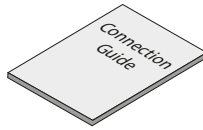

*Connection Guide*



*Laser Key (x2)*

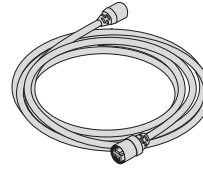

*LAN Cable*

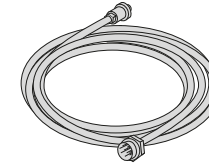

*SCM - MLS Signal Cable*

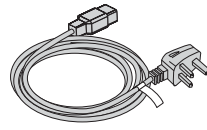

*Power Cable, UK*

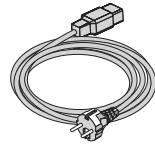

*Power Cable, Europe*

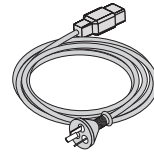

*Power Cable, China*

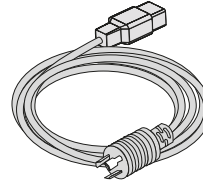

*NEMA L5-20P - C19 Power Cable, North America*

**Modular Light Source - MLS20000, MLS30000 (Shipped Separately)**

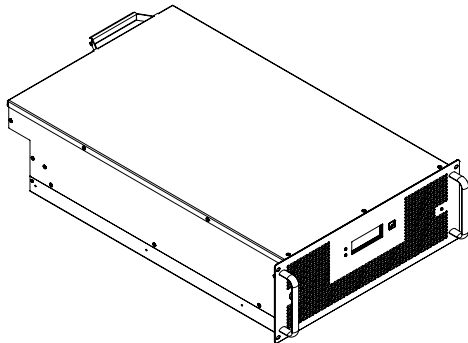

*Modular Light Source (MLS 20000, MLS 30000)*



*Important Please Read Booklet*

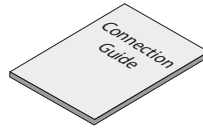

*Connection Guide*



*Laser Key (x2)*



*LAN Cable*

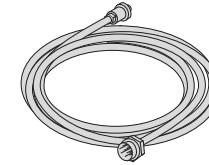

*SCM - MLS Signal Cable*

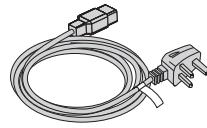

*Power Cable, UK*

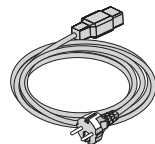

*Power Cable, Europe*

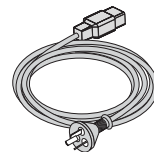

*Power Cable, China*

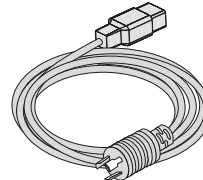

*NEMA L5-20P - C19 Power Cable, North America*

**Notes**

### Satellite Control Module (Shipped Separately)

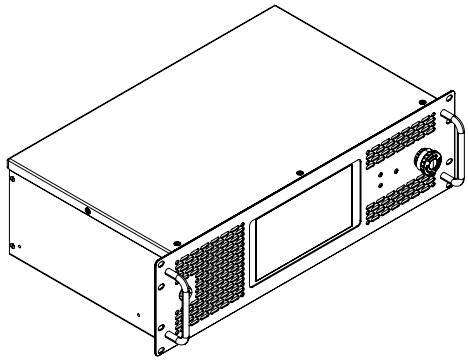

**Satellite Control Module (SCM)**



**Important Please Read Booklet**

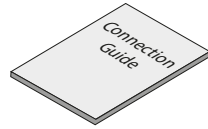

**Connection Guide**



**Laser Key (x2)**

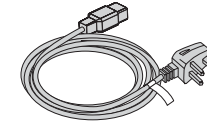

**Power Cable, UK**

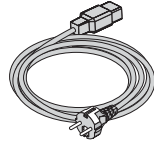

**Power Cable, Europe**



**Power Cable, China**

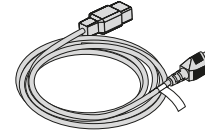

**NEMA 5-15P - C19 Power Cable, North America**

### Notes

**Satellite Link Cable (Shipped Separately)**

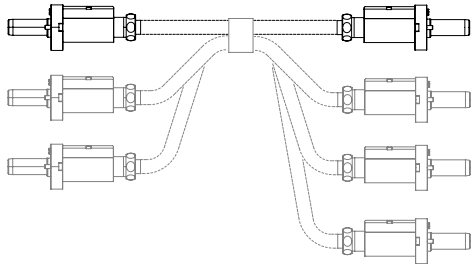

**Satellite Link Cable (SLC)**

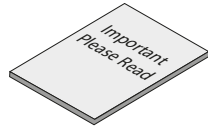

**Important Please Read Booklet**



**LAN Cable**

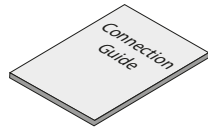



**Connection Guide**





**Hex Driver**

**Notes**

 The SLC connects Modular Light Sources (MLS) to Satellite Heads. The SLC includes a built in junction box with additional MLS or Satellite Head connections when there are multiple MLS or Satellite Heads. Only the appropriate SLC for your projector system is supplied.

 See Satellite Link Cable on page 34 for guidance regarding your installation.

 The appropriate number of LAN cables are included. One LAN cable is supplied per Satellite Head.

 **Handle the SLC with care. Do not drop or knock the SLC when removed from its packaging. The curvature of the SLC should never have a radius of less than 20 cm. Below this, the fiber inside the cable may be damaged.**

# Module Overviews

## Satellite Head

1. Air outlet
2. Air inlet
3. Front infrared window
4. Air inlet
5. Control panel
6. Lens mount
7. Air outlet
8. Connections panel
9. Rear infrared window
10. Mains socket
11. SLC socket
12. Air outlet

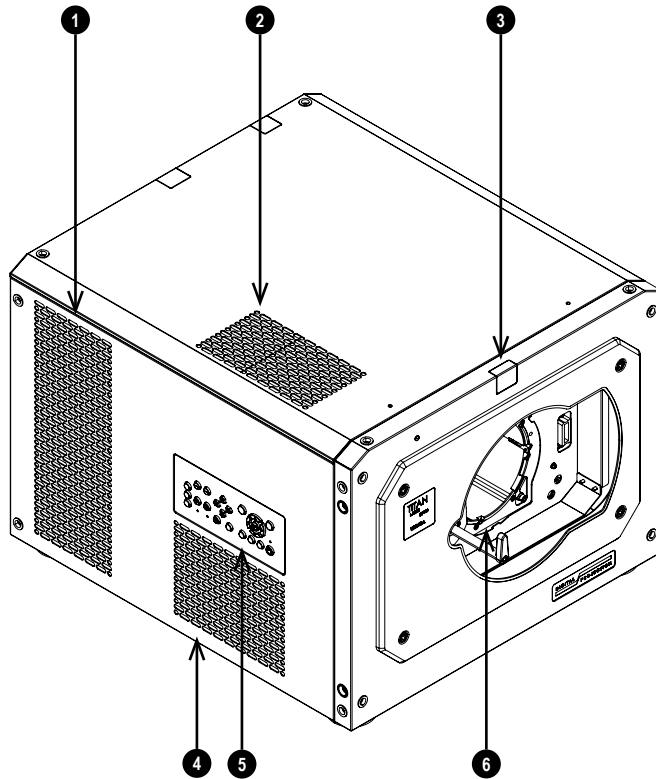

**Satellite Head Front View**

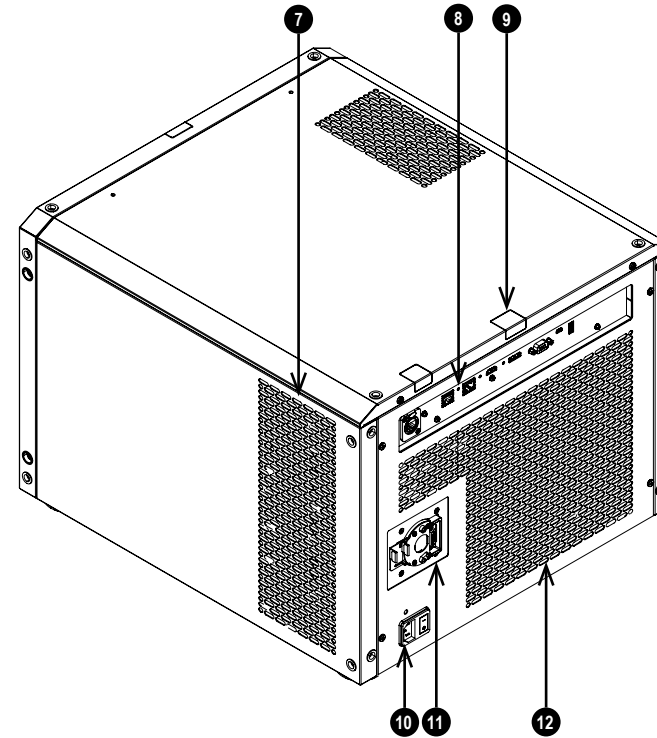

**Satellite Head Rear View**

### Notes

See Product labels on page 140 for details about the labels that are located on the Satellite Head, MLS, SCM and SLC.

## Modular Light Source

### MLS 10000

1. Air inlet
2. Touch Screen Control Panel
3. Air inlet
4. Laser Activation Lock
5. Laser Indicator
6. Air outlet
7. Signal Cable socket
8. LAN socket
9. Mains socket
10. SLC socket

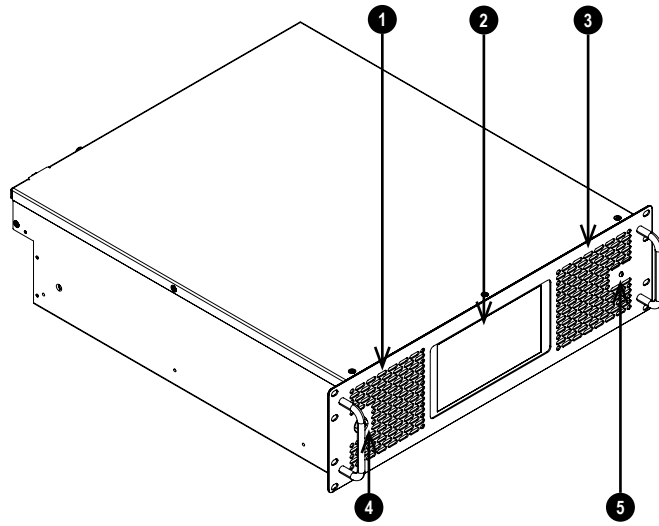

**MLS Front View**

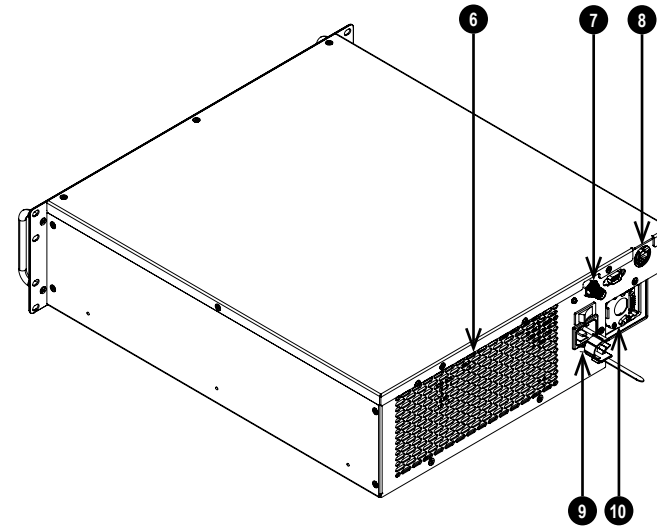

**MLS Rear View**

**Notes**

**MLS 20000 / MLS 30000**

1. LCM Panel
2. Laser Activation Lock
3. Air inlet
4. Laser Indicator
5. Air outlet
6. Mains socket
7. LAN socket
8. SLC socket
9. Signal Cable socket

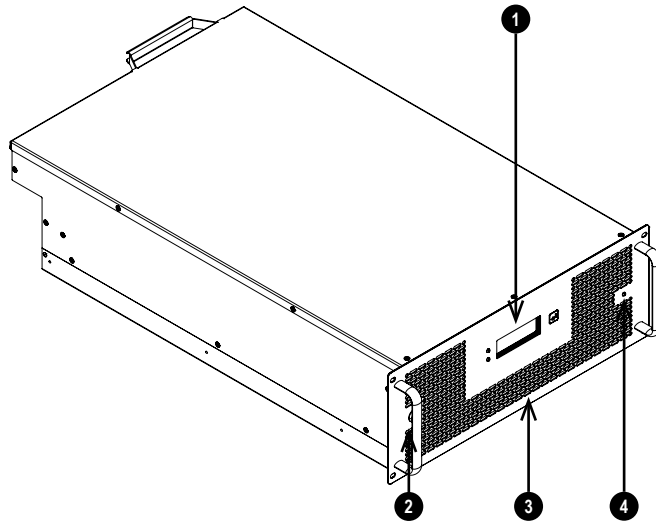

**MLS Front View**

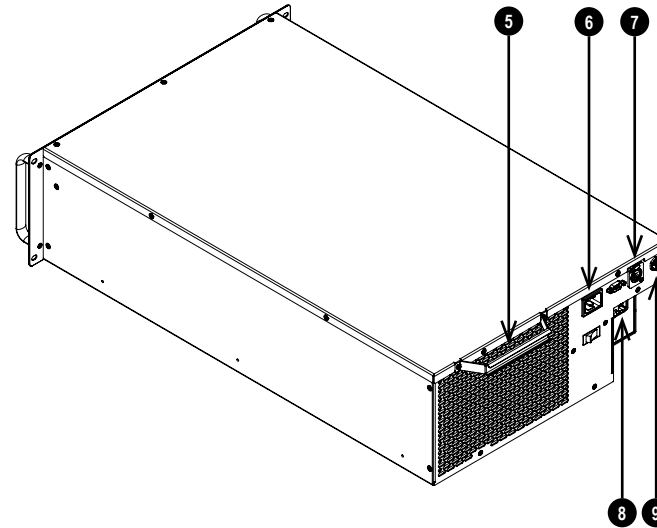

**MLS Rear View**

**Notes**

## Satellite Control Module

1. Air inlet
2. Touch Screen Control Panel
3. Air inlet
4. Emergency Stop
5. Laser Activation Lock
6. SCM Indicators
7. Air inlet
8. Air outlet
9. Connections panel
10. Mains socket

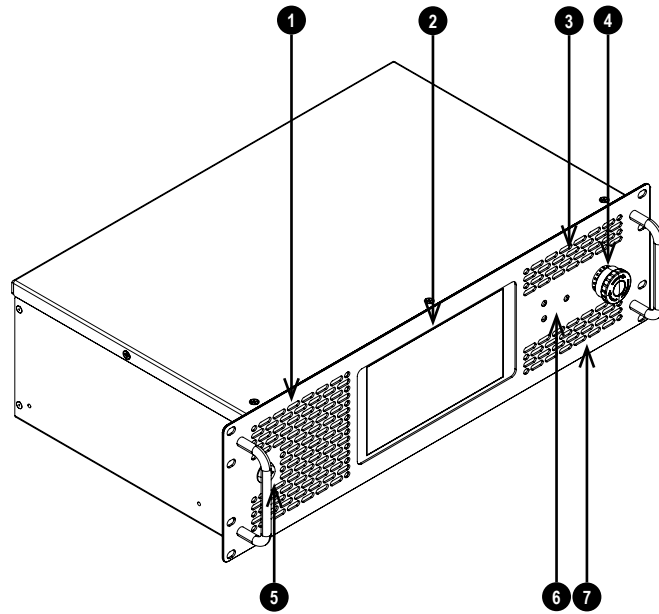

Front View

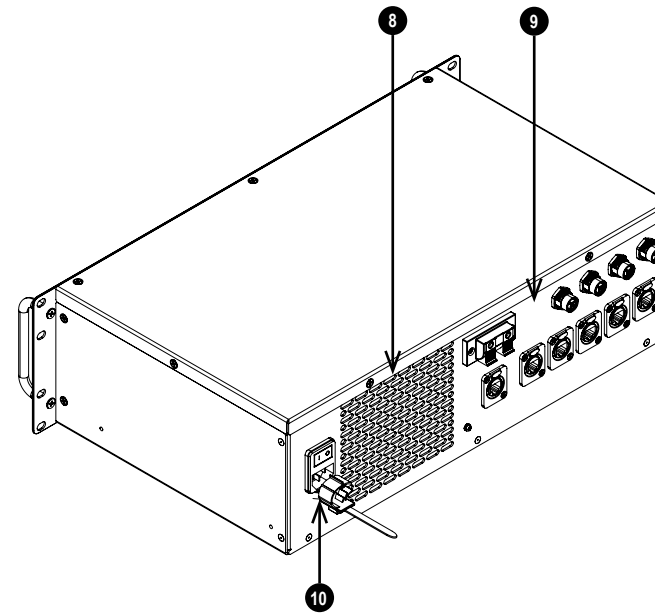

Rear View

### Notes

## Location of Laser Aperture

1. The laser aperture is located as indicated below.



Do not look directly at the light coming from the lens.

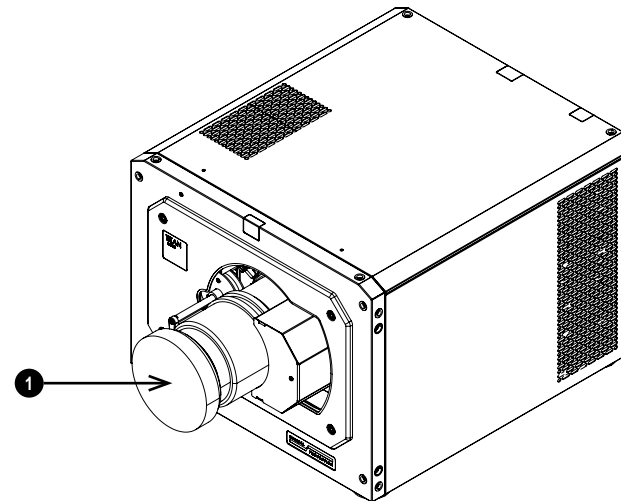

## Interlock Switches

Interlock switches are installed. Any individual interlock switch will power-off the lasers when opened.

## Satellite Head

1. Will be opened when the projection lens is removed or misplaced.
2. Will be opened when the Satellite Link Cable is removed or misplaced.

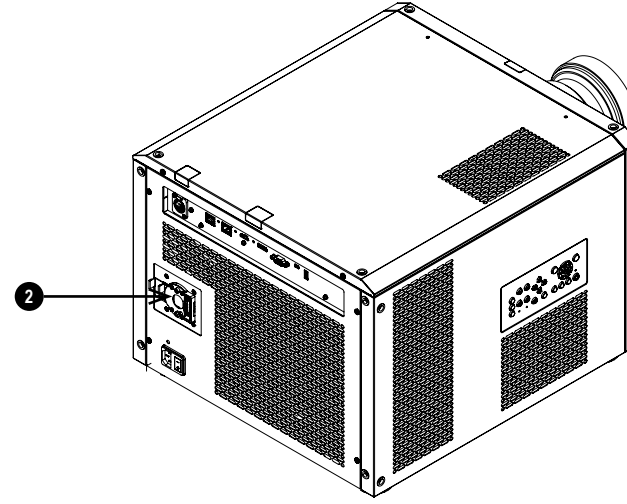
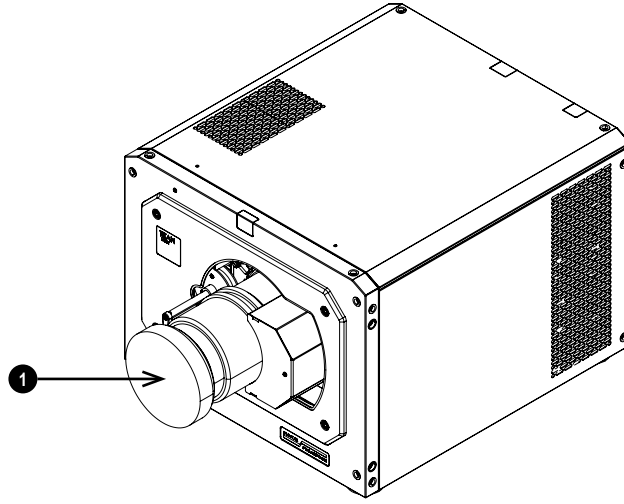

**Notes**

## Modular Light Source - MLS10000

1. Will be opened when the MLS-SCM signal cable is removed or misplaced.
2. Will be opened when the Satellite Link Cable is removed or misplaced.
3. Will be opened when the cover is removed.

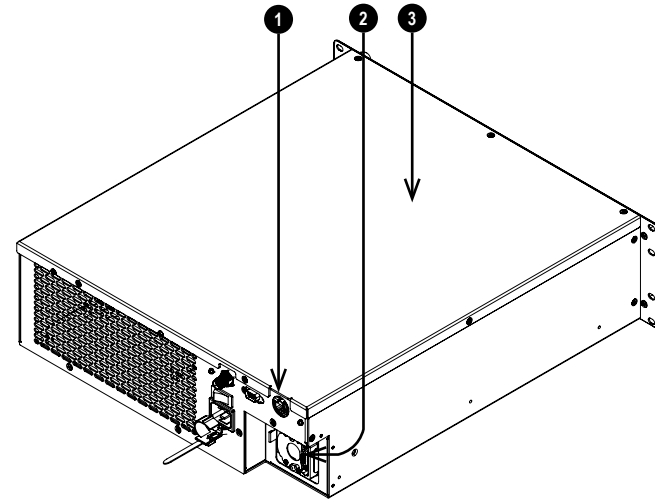

## Modular Light Source - MLS 20000/MLS 30000

1. Will be opened when the MLS-SCM signal cable is removed or misplaced.
2. Will be opened when the Satellite Link Cable is removed or misplaced.
3. Will be opened when the cover is removed.

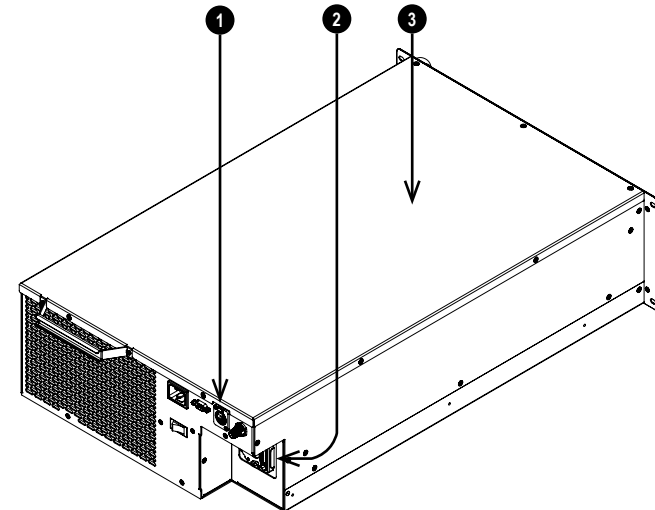

### Notes

## Satellite Control Module

1. External interlock. Use this to allow an external device, such as a door switch, to switch off the laser. The interlock is delivered with a wire link in place. If the link is removed the interlock will open and prevent the laser from turning on.
2. Will be opened when the MLS-SCM signal cable is removed or misplaced.

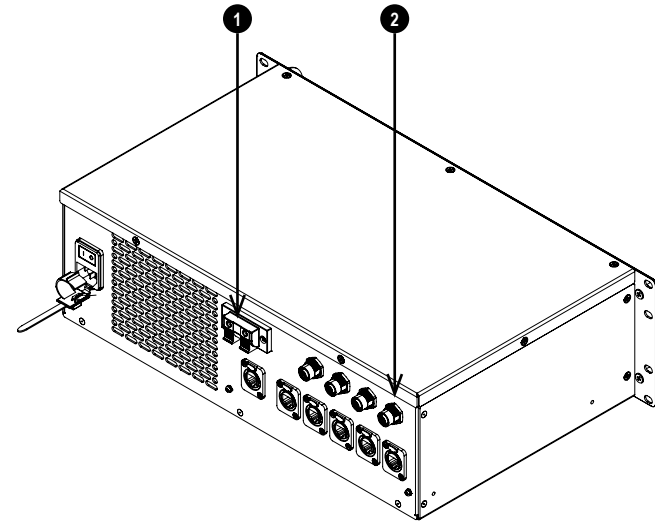

### Notes

## Satellite Link Cable

1. The cable contains a thermal sensor. Avoid direct sources of heat.
2. Will be opened when the Satellite Link Cable is removed or misplaced in the Satellite Head or MLS.

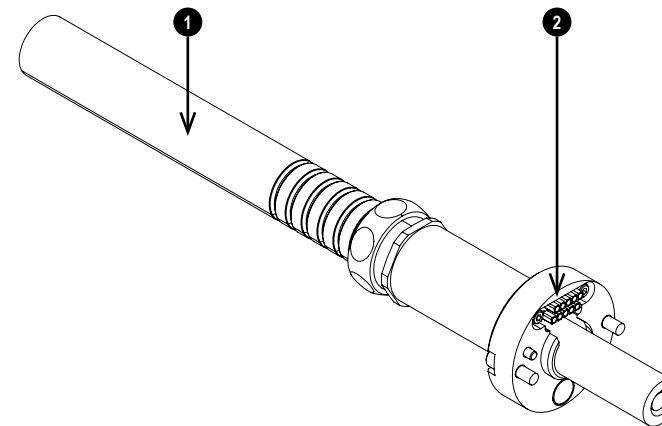

Handle the SLC with care. Do not drop or knock the SLC when removed from its packaging. The curvature of the SLC should never have a radius of less than 20 cm. Below this, the fiber inside the cable may be damaged.



Once the thermal sensor has exceeded its trip level, it cannot be reset. Do not exceed 100°C.

## Installation Precautions



All installations should follow local building and electrical codes of practice

Components of the Satellite MLS are heavy. Use safe handling techniques when lifting.

Do not drop or knock the Satellite Head, Modular Light Source (MLS), Satellite Control Module (SCM) or Satellite Link Cable (SLC).

Use only the power cables, SLC cables and MLS signal cables provided.

The power cables, MLS signal cable, satellite link cable and signal input cable should be connected before the system is powered on.

During startup and operation, DO NOT insert or remove the SLC, MLS signal cable, signal input cable or the power cable to avoid damaging the system.

### Risk Group 3 precautions:



**Warning!** This product is a Class 1, Risk Group 3 Laser Product.

The product should be installed and operated in accordance with the provisions of IEC 62471-5:2015 and the Important Information document and User Manual by instructed and skilled persons only (IEC 62368-1:2020).

Operators shall control access to the beam within the hazard distance or install the product at a height that will prevent exposure of the spectator's eyes within the hazard distance.

No direct exposure to the beam shall be permitted, RG3 IEC 62471-5:2015.

Do not place reflective objects in the projected beam

The hazard zone must be no lower than 3 meters above the floor and the horizontal clearance to the hazard zone must be a minimum of 2.5 meters. See See Risk Group 3 Laser Hazard Installation Precautions on page 37.

### For Installations within the United States:

The following requirements must be in place for installations within the USA:



**Certain US States have additional laser regulatory requirements.**

**Dealers and Distributors of Laser Illuminated Projectors, including installers, must comply with the record keeping requirements described in 21 CFR 1002.40.**

### Risk Group 3:



**Any human access to the hazard zone must be restricted by barriers to enforce the no access zone**

**Permanent show installations containing RG3 laser illuminated projectors must meet the following conditions:**

**Notes**

- Installed by Digital Projection or Digital Projection authorized and trained engineers
- Operated according to instructions provided by Digital Projection
- Ensure the projection system is securely mounted to prevent unintended movement of the projector

**A copy of the FDA Variance Approval Letter must be with the operator or other responsible person**

**Temporary show installations containing RG3 laser illuminated projectors may be installed by Digital Projection, or sold or leased, only to valid laser light show variance holders for image projection applications. This requirement also applies to dealers and distributors of this equipment.**

**For temporary installations, the FDA variance holder must maintain complete records of all show itineraries with dates, locations, operator's name and contact information in a clear and concise way.**

**The Digital Projection Laser Projector Installation Checklist must be fully completed after installation and sent to Digital Projection. The user may retain a copy.**

## Satellite Head



**Do not install the Satellite Head close to anything that might be affected by its operational heat, for instance, polystyrene ceiling tiles, curtains etc. Place the projector in a dry area away from sources of dust, moisture, steam, smoke, sunlight or heat.**

**Ensure that the intake vents do not recycle hot air from the exhaust vent.**

**When operating the Satellite Head in an enclosed space, ensure that the surrounding air temperature within the enclosure does not exceed operation temperature while the Satellite Head is running, and the air intake and exhaust vents are unobstructed.**

**All enclosures should pass a certified thermal evaluation to ensure that the Satellite Head does not recycle exhaust air, as this may cause the device to shutdown even if the enclosure temperature is with the acceptable operation temperature range.**

**Avoid installing at high temperature, insufficient cooling and heavy dust locations.**

**Avoid installing near an air conditioner duct or a subwoofer.**

**The Satellite Head should be installed as close to the power outlet as possible.**

**The power connection should be easily accessible, so that it can be disconnected in an emergency.**



**Please pay attention to Satellite Head installation with respect to other staging laser light equipment set-up. These systems can cause permanent damage to the imaging devices (DMD™) used in the Satellite Head. This damage is not covered by our warranty.**

**When using a Satellite Head in an environment with third party high power laser systems avoid direct laser beams pointing towards the projection lens. This may cause incident light to converge into the optical engine and cause damage to the imaging devices (DMD™).**

**Before installation, make sure that the surface, ceiling or rigging that is to support the Satellite Head is capable of supporting the combined weight of the Satellite Head, lens, SLC and cables.**

**Backup safety chains or wires should always be used with ceiling mount installations.**

**When installing a ceiling mount, make sure the weight limit is not exceeded and the Satellite Head is firmly secured.**

## Notes

The Satellite Head can be operated any position, as shown in the diagram:

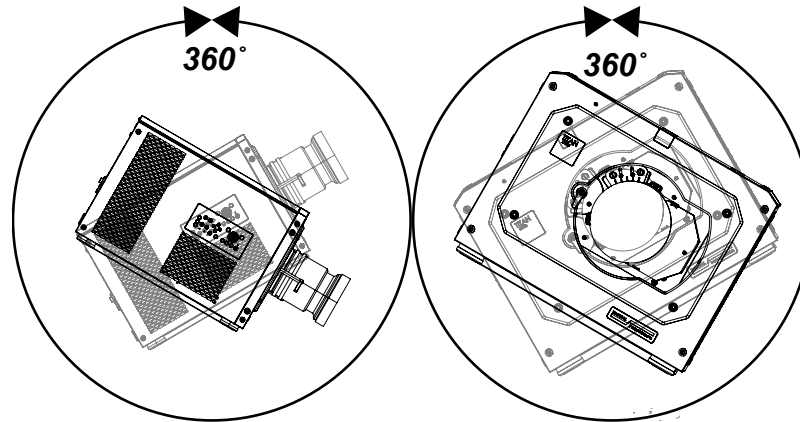

*Tilt (Left) and Roll (Right)*

Allow at least 50cm (19.7in) of space between the ventilation outlets and any wall, and 30cm (11.8in) on all other sides.

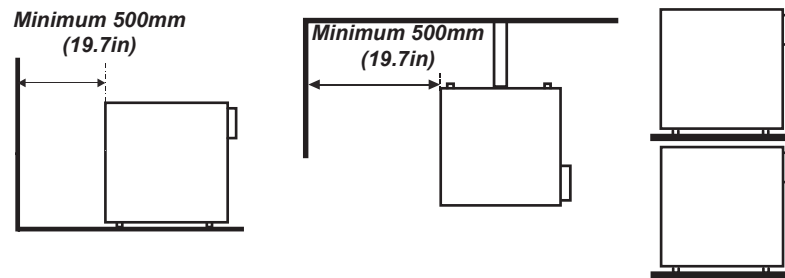

*Example Positioning*

When stacking the Satellite Head, the stack **MUST** be vertical, to ensure that the stresses are distributed to all four chassis corners.

Do not stack more than 2 Satellite Heads.

**Notes**

**Make sure that there is a 3cm (1.2in) gap between Satellite Heads when stacked.**

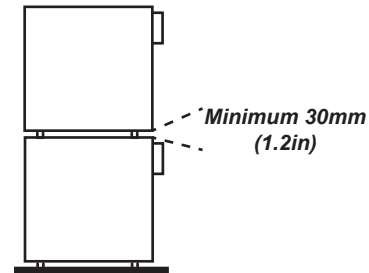

*Example Stacking*



**Make sure the lens cap is removed from the lens before operating the Satellite MLS. Light energy levels have been known to cause damage to both the lens and projector optics. This damage is not covered by our warranty.**

**Make sure the lens cap is removed from the rear of the lens before it is inserted into the Satellite Head .**

**Connect the LAN cable only to a computer LAN connection. Other similar connectors may have a dangerously high voltage source.**

**The Satellite Head generates heat during use. The internal fans dissipate the heat of the Satellite Head when shutting down, which could continue for a certain period. After the projector enters STANDBY MODE, remove the power cord. DO NOT remove the power cord during shutdown as it may cause damage to the Satellite Head and may affect the service life of the Satellite Head .**

**Do not place heavy objects on top of the Satellite Head .**

**Notes**

## Modular Light Source and Satellite Control Module



The MLS and SCM are designed to be installed in a rack system. The MLS and SCM can also set up in a free standing installation. Rack installation is preferable.



The MLS must be mounted or placed horizontally during operation.



The laser colors must be calibrated after installation or after changing MLS within a system. See Laser color calibration on page 66 for guidance.

### Rack Mounts



Do not install the rack containing the MLS and SCM close to anything that might be affected by its operational heat, for instance, curtains or other combustible materials etc.

Place the rack in a dry area away from sources of dust, moisture, steam, smoke, sunlight or heat.

Inside the rack, make sure there is a space between MLS and SCM modules.



Air vents are located at the front and rear of the modules. Make sure that the air intake and exhaust vents on the MLS and SCM are unobstructed and that the intake vent does not recycle hot air from the exhaust vent.

Make sure that the rack mount is ventilated and that any door or coverings include ventilation holes.

Make sure that the surrounding air temperature within the rack does not exceed operation temperature while the MLS and SCM are running. The rack mount should pass a certified thermal evaluation to ensure that the MLS and SCM do not recycle exhaust air, as this may cause the system to shutdown even if the temperature is within the acceptable operation temperature range.

Avoid installing at high temperature, insufficient cooling and heavy dust locations.

Avoid installing near an air conditioner duct or a subwoofer.

The rack mount should be installed as close to the power outlet as possible.

The EMERGENCY OFF button on the SCM should be easily accessible.

### Free Standing



Do not install the MLS and SCM close to anything that might be affected by its operational heat, for instance, polystyrene ceiling tiles, curtains etc.



Place the MLS and SCM in a dry area away from sources of dust, moisture, steam, smoke, sunlight or heat.



Air vents are located at the front and rear of the modules. Make sure that the air intake and exhaust vents on the MLS and SCM are unobstructed and that the intake vent does not recycle hot air from the exhaust vent.

### Notes

**Allow at least 50cm (19.7in) of space between the ventilation outlets and any wall.**

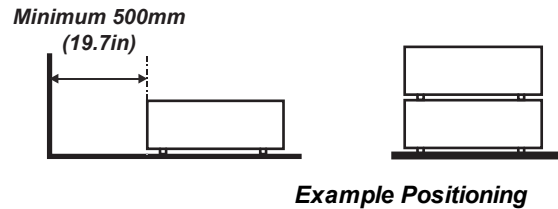

## Notes



When operating the MLS and SCM in an enclosed space, ensure that the surrounding air temperature within the enclosure does not exceed operation temperature while the MLS and SCM are running. All enclosures should pass a certified thermal evaluation to make sure that the MLS and SCM do not recycle exhaust air, as this may cause the system to shutdown even if the enclosure temperature is within the acceptable operation temperature range.

Avoid installing at high temperature, insufficient cooling and heavy dust locations.

Avoid installing near an air conditioner duct or a subwoofer.

The MLS and SCM should be installed as close to the power outlet as possible.

The EMERGENCY OFF button on the SCM should be easily accessible.

Before installation, make sure that the surface is capable of supporting the weight of the MLS or SCM.

When installed, make sure the MLS is level with a maximum deviation of +/- 7 degrees.

When stacking MLS or SCM, the stack **MUST** be vertical, to ensure that the stresses are distributed to all four chassis corners.

Do not stack more than 3 MLS or SCM.

Make sure that there is a 3cm gap between MLS when stacked.

The MLS and SCM modules generate heat during use. The internal fans dissipate the heat of the MLS or SCM when shutting down, which could continue for a certain period. After the projector enters STANDBY MODE, remove the power cord. **DO NOT** remove the power cord during shutdown as it may cause damage to the MLS or SCM and may affect the service life.



Do not place heavy objects on top of the projector MLS or SCM.

## Satellite Link Cable



Handle the SLC with care. Do not drop or knock the SLC when removed from its packaging. The curvature of the SLC should never have a radius of less than 20cm. Below this, the fiber inside the cable may be damaged.

When spooling cable in multiple loops, maintain a minimum diameter of 80cm and avoid twisting the cable.

The end caps on the Satellite Link Cable should remain in place until fitting.

When installed in trunking, the SLC should be hand laid along the entire length of trunking. Do not pull the cable through a conduit.

Use a cable protector at any location where the cable may be exposed to traffic.

Avoid installing the cable at locations where it may be exposed to high temperatures. The Satellite Link Cable contains a thermal sensor, avoid direct sources of heat. Do not exceed 100°C. If the thermal sensor exceeds its trip level it cannot be reset and the interlock circuit will remain open.

Make a basic visual inspection on the ends of the Satellite Link Cable to check for dust. Cleaning with cloth should be avoided and only an optical grade aerosol type duster should be used sparingly.

When removing the cable, it should be rolled up to avoid twisting the cable. Maintain a minimum diameter of 80cm when rolling the cable up.

## Handling Precautions

The SLC must be handled with care. The SLC can be damaged if handled improperly. Follow the handling procedures shown in this document to prevent damage to the SLC assembly.

Digital Projection Ltd. will not guarantee or be held responsible for any damage caused when failing to follow these precautions:

 Unroll the product from its packaging to avoid any twisting in the SLC.

Do not allow kinks or knots to develop in the SLC.

Do not bend the SLC tighter than a 20cm radius.

Hold the SLC connector when connecting or unplugging it from a device.

Never use the SLC to pick up or drag the device to which it is attached.

The end of the connector is an exposed glass surface. This is fragile, take care not to damage it. Keep the protective caps in place when not in use.

Do not let the SLC dangle over sharp corners.

Do not place anything heavy on the SLC. Do not allow a heavy object to fall on the cable. Do not stand on the cable.

Prevent any contamination of the connectors. See Cleaning the SLC on page 169 for information on cleaning a contaminated SLC.

Do not disassemble the optical connectors.



## Notes

## Laser Safety Precautions

 **Warning! Death or Serious Injury could occur if the following precautions are ignored**

 **Permanent/Temporary Blindness Hazard**

Do not look directly into the lens when the light source is on. The high brightness can cause permanent eye damage.

 **Caution – use of controls or adjustments or performance of procedures other than those specified herein may result in hazardous radiation exposure.**

Do not attempt to operate the product without covers in place.

This product (MLS) has a built in Class 4 laser module. Do not attempt to disassemble or modify the laser module.

Lens Change should only be carried out by instructed and skilled persons in accordance with the Important Information document or User Manual. If in doubt consult your dealer.

Ensure the projector is switched off and AC power removed before attempting a lens change

### Laser Risk Group 3 Precautions

 **Not for household use.**

 **Class 1 Laser Product, BS EN IEC 60825-1:2014.  
No direct exposure to the beam shall be permitted, RG3 BS EN IEC 62471-5:2015.**

Operators shall control access to the beam within the hazard distance or install the product at a height that will prevent exposure of the spectator's eyes within the hazard distance. See Light Hazard Distance and Hazard Zone on page 38 for more information.

The product should be installed and operated in accordance with the provisions of BS EN IEC 62471-5:2015 and the Important Information document or User Manual by instructed and skilled persons only (BS EN IEC 62368-1:2020).

### Notes



See Satellite Head on page 140 for details about the labels that are located on the Satellite Head, MLS, SCM and SLC.

## Risk Group 3 Laser Hazard Installation Precautions



Do not attempt to access the internal hardware of the projector. Do not attempt to modify or remove the laser module.

Do not operate the projector without its protective covers.

Please make sure that the Satellite system is fully powered down and disconnected from the mains before changing the lens.

Do not operate the projector without a lens installed.

### Laser Risk Group 3 Installation Precautions



This product is a Class 1 Risk Group 3 laser product. It must be installed in a safe place and must be handled by qualified and professionally trained personnel.

Operators shall control access to the beam within the hazard distance or install the product at a height that will prevent exposure of the spectator's eyes within the hazard distance.

The product should be installed and operated in accordance with the provisions of BS EN IEC 62471-5:2015 and the Important Information document or User Manual by instructed and skilled persons only (BS EN IEC 62368-1:2020).

### Light Hazard Warning



No direct exposure to the beam is permitted, RG3 BS EN IEC 62471-5:2015.

Operators should control access to the beam within the hazard distance or install the projector at sufficient height to prevent exposures of spectators' eyes within the hazard area.

When the laser is installed overhead, allow a minimum of 3m between the floor surface and the Risk Group 3 area.

**Notes**

### Light Hazard Distance and Hazard Zone

The hazard distance is the distance measured from the projection lens at which the intensity or energy per unit of surface is lower than the applicable exposure limit on the cornea or skin. ①

The hazard zone is the area from the projection lens up to the hazard distance that encompasses where the projected beam is considered hazardous. ②

If the person is within the hazard zone, the beam is considered unsafe for exposure.

The hazard distance for this projector is related to the fitted lens and the light output at the Satellite Heads.

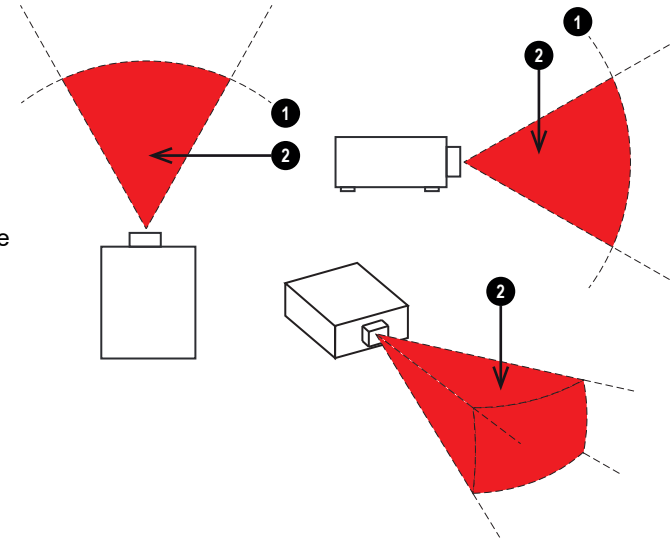

#### Notes

*The light output at each satellite head is related to the total light output from the MLS and the number of heads. See Laser Parameters on page 7 for more information on the light output.*

**Operators should control access to the beam within the hazard distance or install the projector at sufficient height to prevent exposures of spectators' eyes within the hazard area.**

**When the laser is installed overhead, allow a minimum of 3m between the floor surface and the Light Hazard Zone.**



Light output (klm) at each Satellite Head	Hazard Distance (m)										
	0.37 : 1	0.65 - 0.85: 1	0.67 : 1	0.8 - 1.16 : 1	1.12 : 1	1.16 - 1.49:1	1.39 - 1.87:1	1.87 - 2.56:1	2.56 - 4.16:1	4.16 - 6.96:1	6.92 - 10.36:1
2.5 klm	0	0	0	0	0	0	0	0	0	1.4	1.7
3.3 klm	0	0	0	0	0	0	0	0	1.2	1.6	1.9
5 klm	0	0	0	0	0	0	0	1.1	1.5	1.9	2.5
10 klm	0	0	0	0	0	1.1	1.3	2	1.9	2.7	3.5
15 klm	0	0	0	1.1	0	1.4	1.8	2.5	3.1	3.7	4.5
20 klm	0	1.1	0	1.5	0	1.6	2.2	2.8	3.5	4.2	5
30 klm	0	2.3	1.2	2.2	1.8	4	3.5	4.2	5	6	7

## Restriction Zone

A restriction zone should be in place around the hazard zone to prevent any person from entering the hazard zone with any part of their body:

- Horizontal clearance **1**. This should be no less than 2.5m around the hazard zone **2**.
- Vertical clearance **3**. This should be no less than 3m between the hazard zone **2** and the floor when the projector is installed overhead.

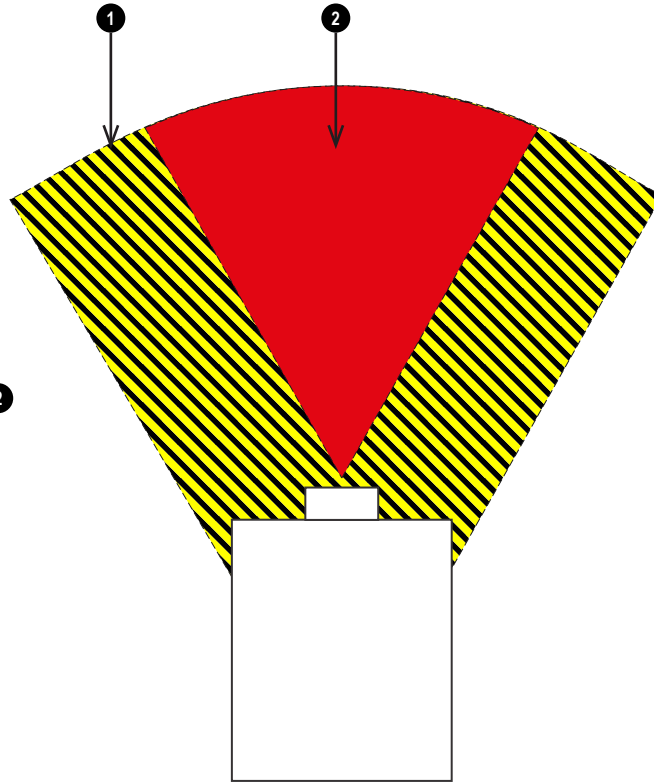

**Hazard Zones - Horizontal Clearance (Top View)**

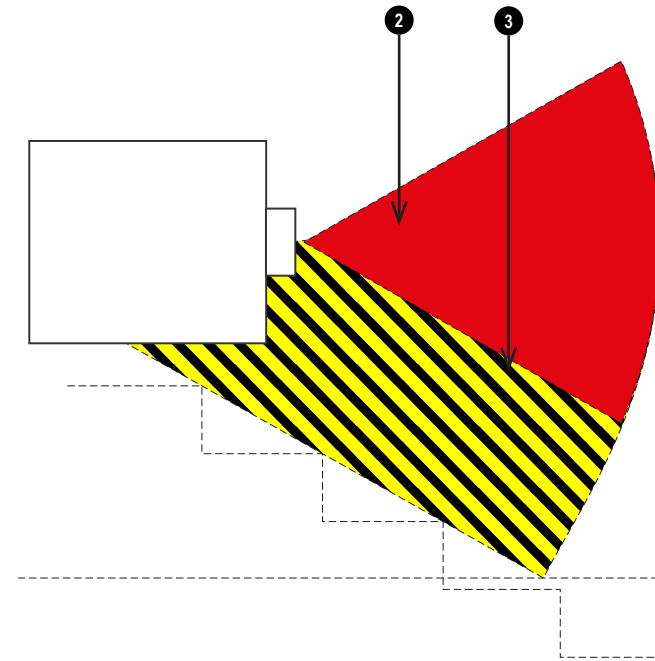

**Hazard Zones - Vertical Clearance (Side View)**

## Notes

## Fitting a lens

The following lenses are available for this Satellite Head:

### Inserting a new lens

1. Remove the lens aperture cap or lens from the projector. See Removing the lens on page 42 for guidance on removing a lens.
2. Turn the lens release lever clockwise so that it is pointing upwards, to open the lock fully. ❶
3. Remove the rear lens cap from the lens.

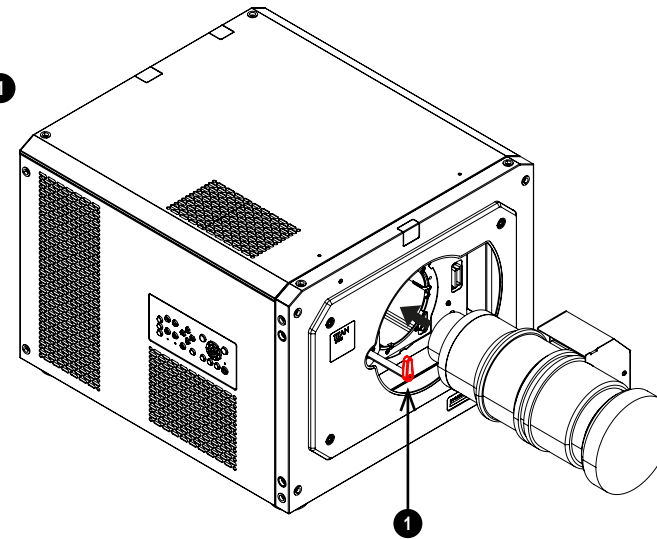

### Notes



The system must be fully turned off prior to attempting a lens change.



When changing the lens, avoid using excessive force as this may damage the equipment.



Avoid touching the surface of the lens as this may result in image impairment.



The lens is shipped separately.



Take care to preserve the original lens packaging and protective caps for future use.



An adapter is available for certain third party lenses. Please see your local dealer for further information.



See Choosing a lens on page 151 for details about the lenses available for the Satellite Head.

4. Insert the lens into the lens aperture, making sure that the plug on the zoom drive mechanism lines up with the socket on the front of the projector, then push the lens in firmly as far as it will go.
5. Turn the lens release lever anti-clockwise to the mid-position. **2**

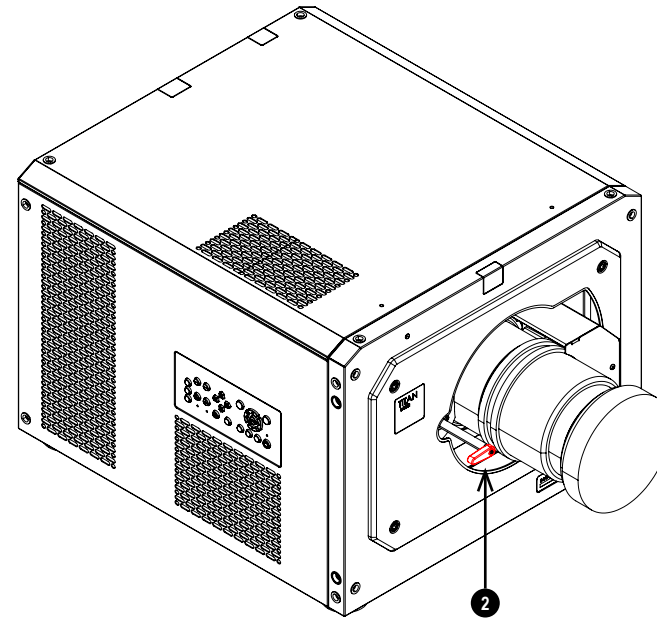

6. The lens can now be pushed in further. Push the lens in firmly as far as it will go.
7. Turn the lens release lever fully anti-clockwise until it is pointing down, to close the lock fully. **3**

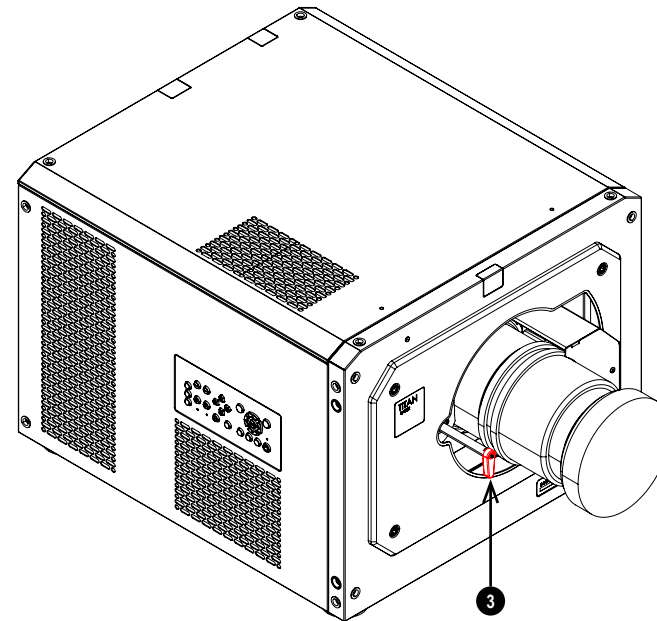
**Notes**

## Removing the lens

1. Turn the release lever up to the mid-position **1**, then pull the lens out as far as it will go.
2. Turn the release lever clockwise until it is pointing up, then pull the lens out completely.
3. Fit lens caps to the front and rear of the lens.
4. Fit a lens aperture cap or a new lens to the projector. See Inserting a new lens on page 40 for guidance on inserting a lens.

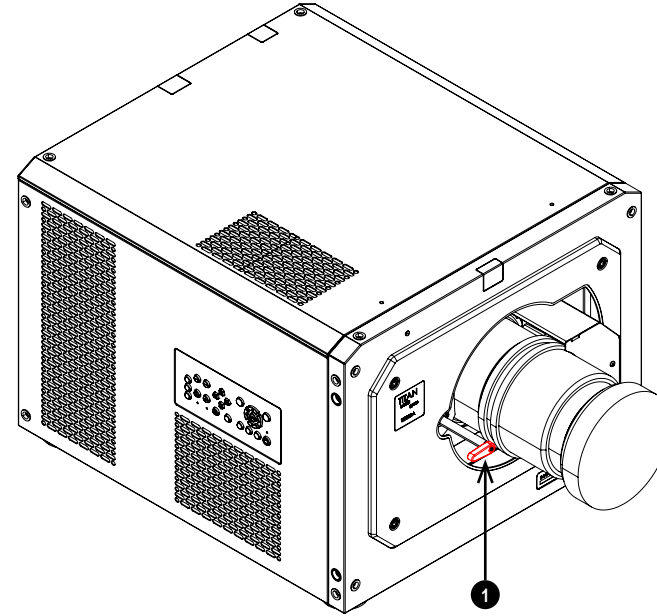

## Notes

## Fitting a lens stabilizing bracket

In some applications and projector orientations, it may be necessary to fit the stabilizing bracket to the lens mount.

1. Remove the cover **1** from the front of the projector
2. Remove the lens mount and lens **2**

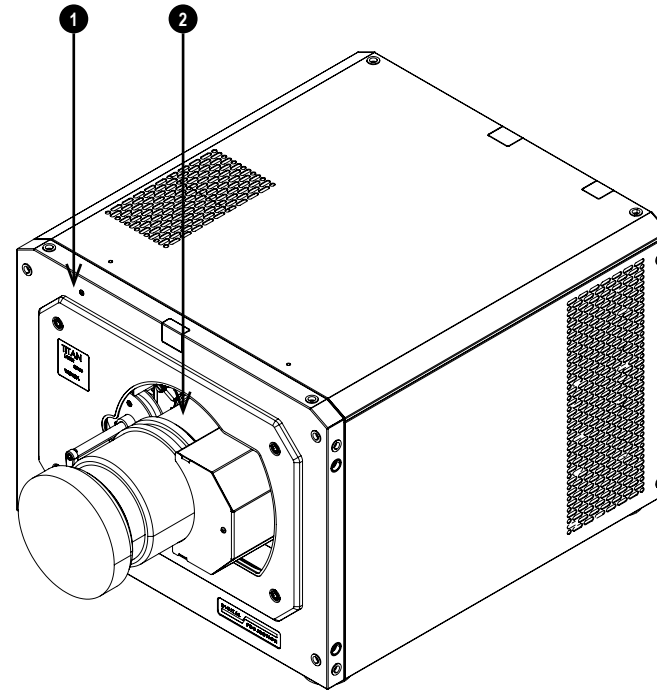

3. Remove the three M3 set screws **3** from the lens collar
4. Remove the two M3 screws **4** from the fixed lens bracket
5. Remove the lens collar from the lens mount

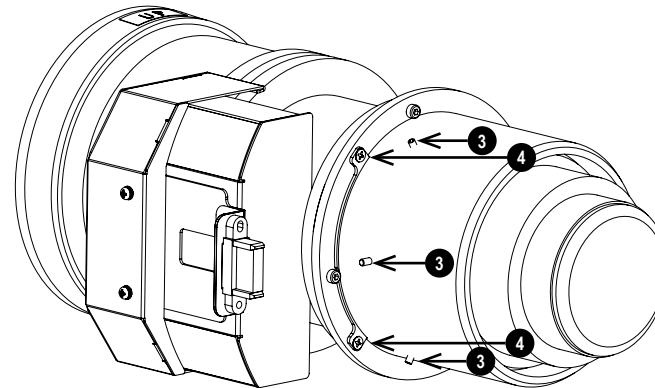

### Notes

6. Remove the two M2 screws **5** from the fixed lens bracket
7. Remove the fixed lens bracket **6**

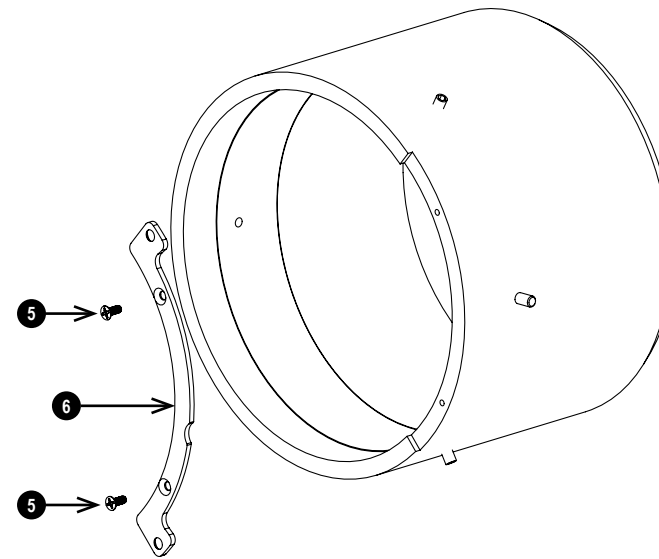

8. Place the stabilizing bracket **7** on to the lens collar
9. Screw in the two M2 screws **8** to fix the stabilizing bracket to the lens collar

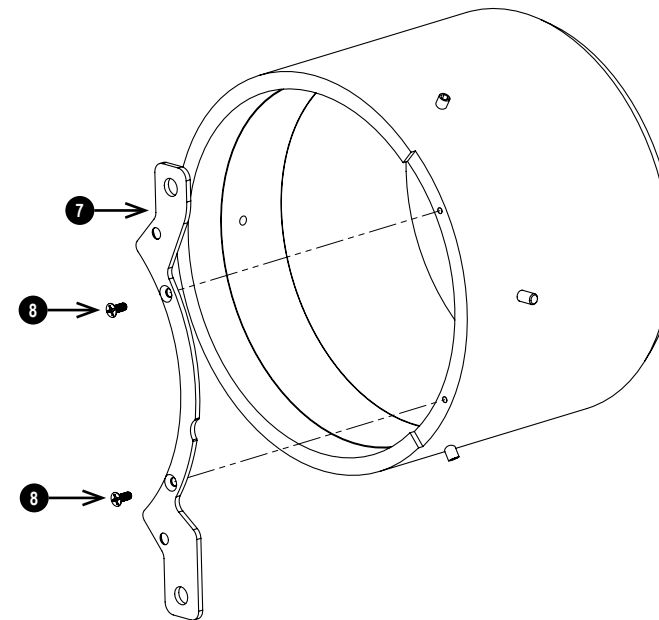

**Notes**

10. Place the lens collar **9** on to the lens
11. Screw in the two M3 screws **10** to fix the lens collar to the lens
12. Screw in the three M3 set screws **11** to the lens collar

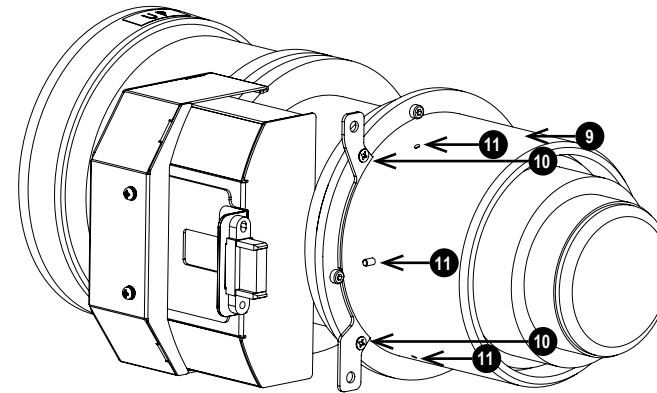
**Notes**

13. Place the lens into the projector
14. Screw the two fixing screws **12** into the lens stabilizing bracket
15. Place the cover over the front of the projector

## Positioning the screen and Satellite Head

1. Install the screen, ensuring that it is in the best position for viewing by your audience.
2. Mount the Satellite Head, ensuring that it is at a suitable distance from the screen for the image to fill the screen.

The drawing shows the positions of the mounting points:

- **Four adjustable feet for tabletop mount ①.**

Set the adjustable feet so that the Satellite Head is level, and perpendicular to the screen.

Remove the feet and fit them to the top of the Satellite Head if you need to invert the Satellite Head during tabletop use.

- **Four M6 holes for ceiling mount ②.**

The mounting screws should not penetrate more than 12 mm into the body of the projector.

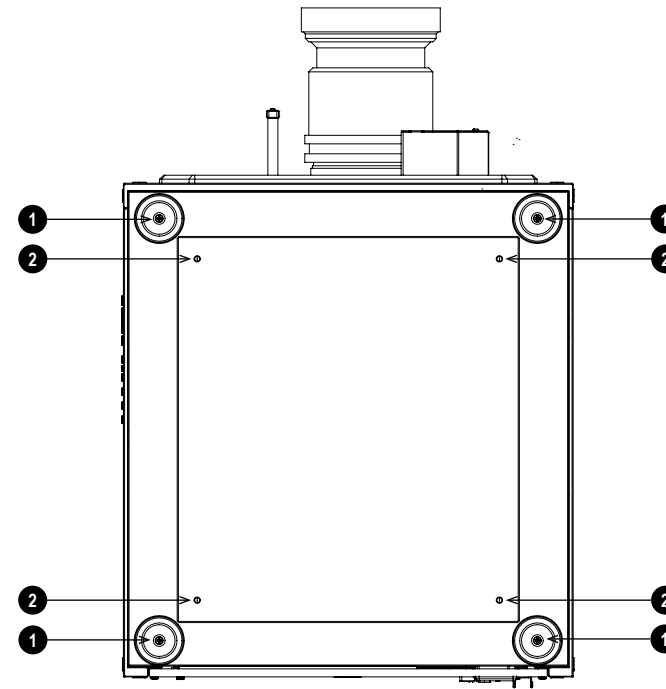

Satellite Head Bottom

### Notes



Always allow the Satellite Head to cool for 5 minutes before disconnecting the power or moving the Satellite Head .



Ensure that there is at least 50 cm (19.7 in) of space between the ventilation outlets and any wall, and 30 cm (11.8 in) on all other sides.



Do not use the threaded holes for the adjustable feet to hang or mount the Satellite Head.



Avoid extending the adjustable feet to the limit of the thread.

## Mounting the rack mount modules

1. Fit any shelves or rails to the rack as required.
2. Fit any rails or mount supports to the Modular Light Source (MLS) or Satellite Control Module (SCM) as required.
3. Mount the module into the rack and secure in place with 4 standard rack locating bolts

### MLS 10000

The drawing shows the positions of the fixing holes for the mount supports and rack locating bolts on the MLS.

1. **Four standard rack locating bolt holes** ①.
2. **Six M4 fixing holes** ② for mounting rails or supports. The screws should not penetrate more than 10 mm into the body of the MLS.

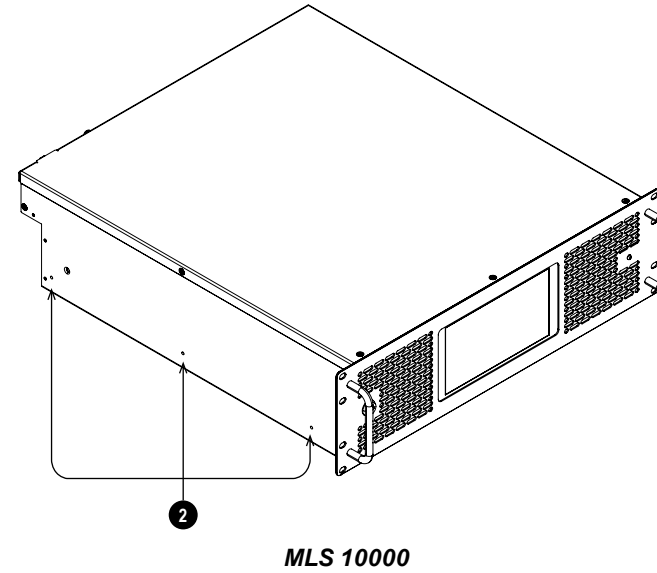
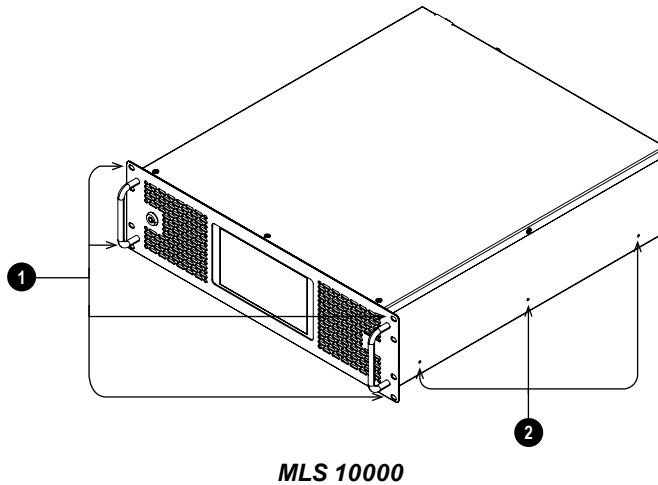

### Notes

### MLS 20000/MLS 30000

The drawing shows the positions of the fixing holes for the mount supports and rack locating bolts on the MLS.

1. **Four standard rack locating bolt holes ①.**
2. **Six M4 fixing holes ② for mounting rails or supports.** The screws should not penetrate more than 10 mm into the body of the MLS.

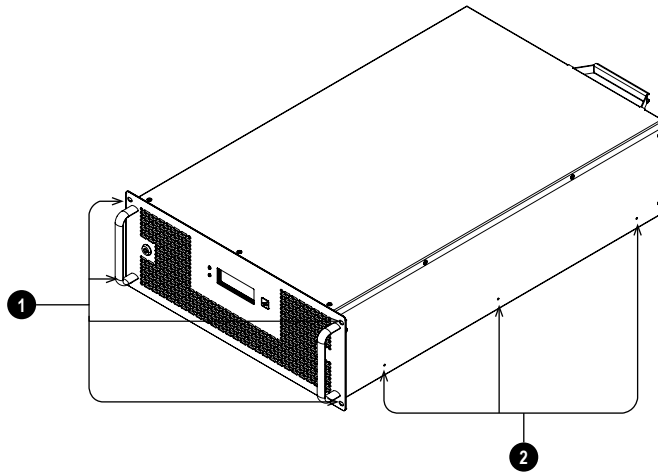

MLS 20000/MLS 30000

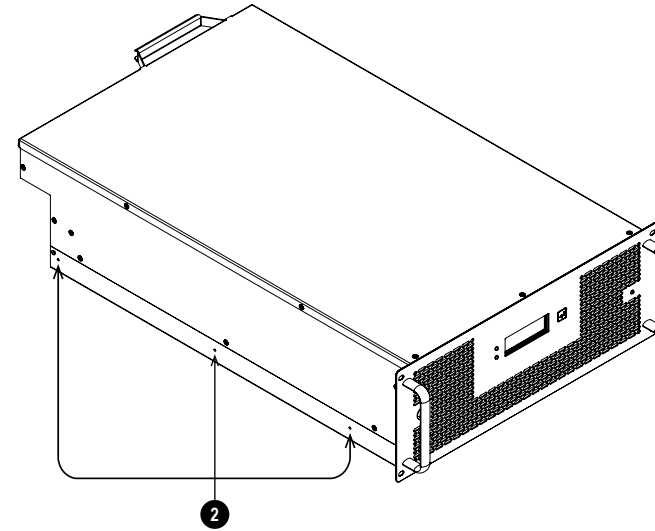

MLS 20000/MLS 30000

### SCM

The drawing shows the positions of the fixing holes for the mount supports and rack locating bolts on the SCM.

1. **Four standard rack locating bolt holes ①.**
2. **Four M4 fixing holes ② for mounting rails or supports.** The screws should not penetrate more than 10 mm into the body of the SCM.

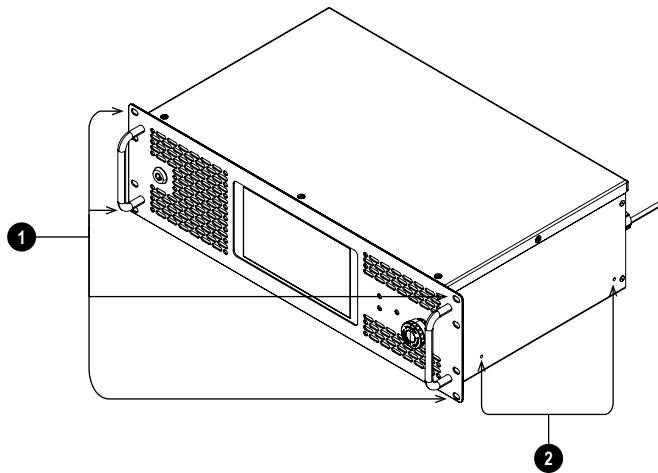

SCM

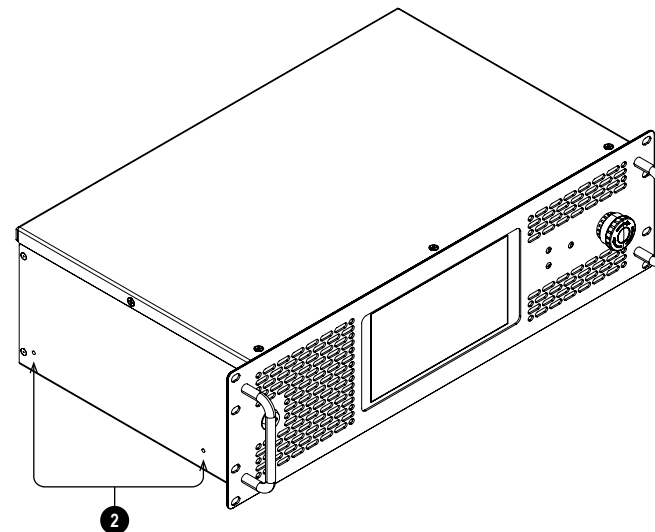

SCM

Notes

## Connecting the Satellite Link Cable

The Satellite Link Cable (SLC) must connect each Satellite Head to one or more Modular Light Sources (MLS). The type of SLC that is supplied depends on the number and type of connections required for your system:

- 1:1. This system uses a single end-to-end cable to connect a single MLS to a single Satellite Head.
- n:1. This system connects between two and three MLS to a single Satellite Head. A single cable is supplied for this purpose. The cable includes a junction box with multiple MLS connectors extending from one side and one Satellite Head connector extending from the other.
- 1:n. This system connects a single MLS to between two and four Satellite Head. A single cable is supplied for this purpose. The cable includes a junction box with a single MLS connector extending from one side and multiple Satellite Head connectors extending from the other.

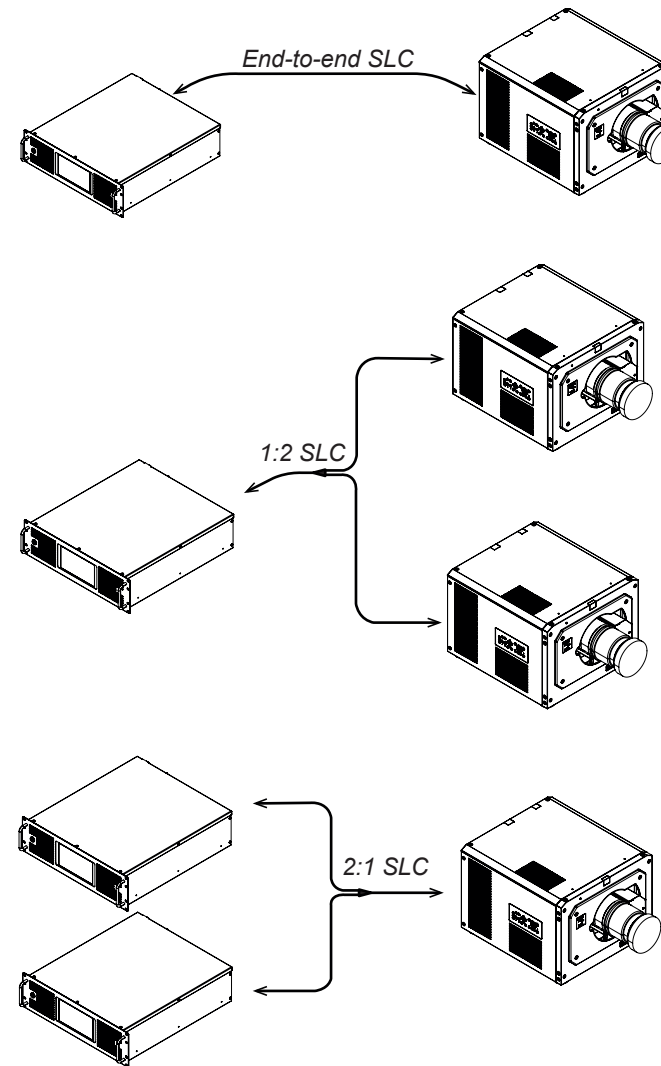

### Notes

Handle the SLC with care. Do not drop or knock the SLC when removed from its packaging. The curvature of the SLC should never have a radius of less than 20 cm. Below this, the fiber inside the cable may be damaged.



The appropriate SLC cables are supplied with the system. Use only the SLC cable provided.



It may be necessary to clean the SLC connectors before installation. See *Cleaning the SLC* on page 169.



The connectors at each end of the SLC are identified by polarity pins and holes:

- A connector with a polarity hole **1** can only connect to a MLS.
- A connector with two polarity holes **1** can only connect to a MLS.
- A connector with a polarity pin **2** can only connect to a Satellite Head.



To fit the SLC to the Satellite Head :

1. Remove the end cap from the SLC-Satellite Head connector.
2. Slide the protective cover on the SLC socket on the Satellite Head open **1**.
3. Align the polarity pin on the SLC **2** with the polarity hole on the SLC socket.
4. Insert the SLC.
5. Use the hex driver to screw in the fixing screw on the SLC and secure it in place.

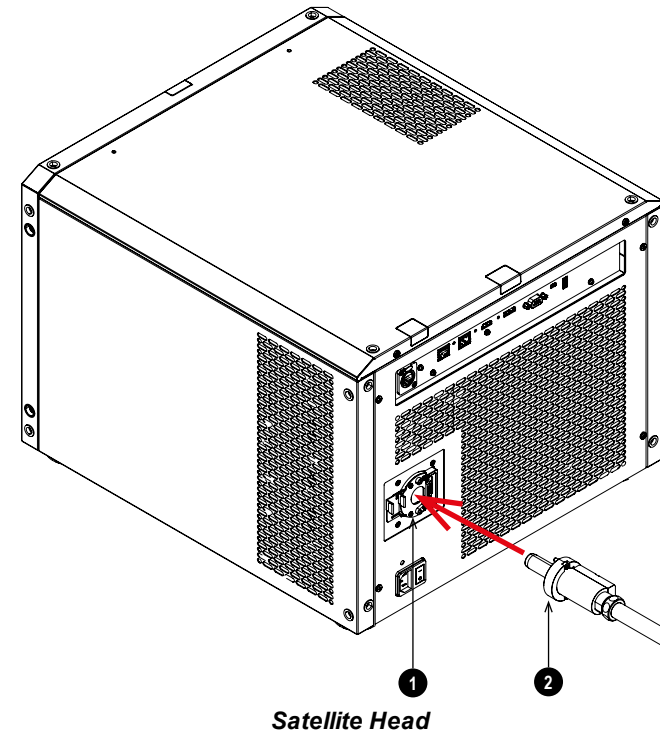

**Notes**

To fit the SLC to the MLS:

1. Remove the end cap from the SLC-MLS connector.
2. Slide the protective cover on the SLC socket on the MLS open **1**.
3. Align the polarity hole on the SLC **2** with the polarity pin on the SLC socket.
4. Insert the SLC.
5. Use the hex driver to screw in the fixing screw on the SLC and secure it in place.

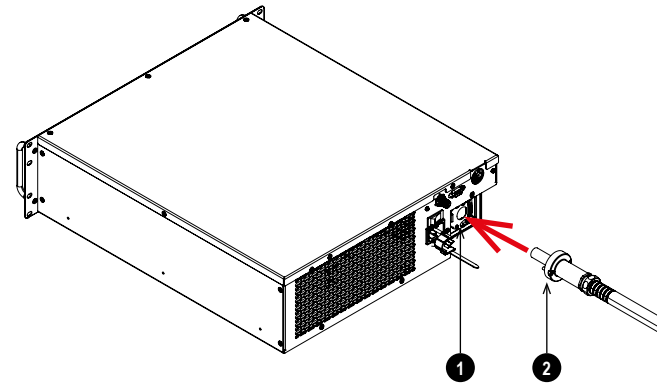

*MLS 10000*

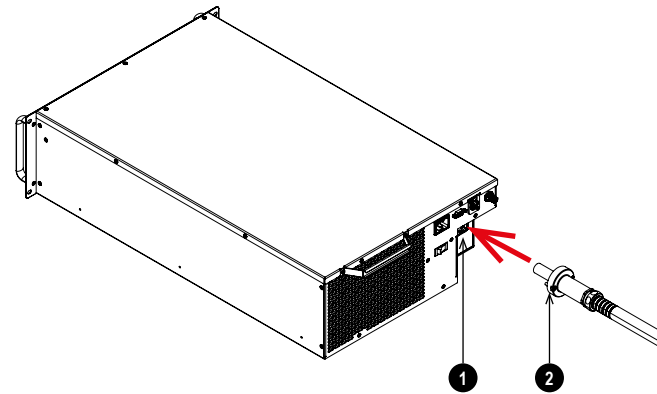

*MLS 20000/MLS 30000*

**Notes**

## Connecting the Signal and LAN cables

Each Modular Light Source (MLS) must be connected to the Satellite Control Module (SCM) with a signal cable and a LAN cable. Each Satellite Head must be connected to the SCM with a LAN cable.

- 1:1. One MLS and one Satellite Head are connected to the SCM.
- n:1. Up to three MLS and one Satellite Head can be connected to the SCM.
- 1:n. Up to four Satellite Head and one MLS can be connected to the SCM.

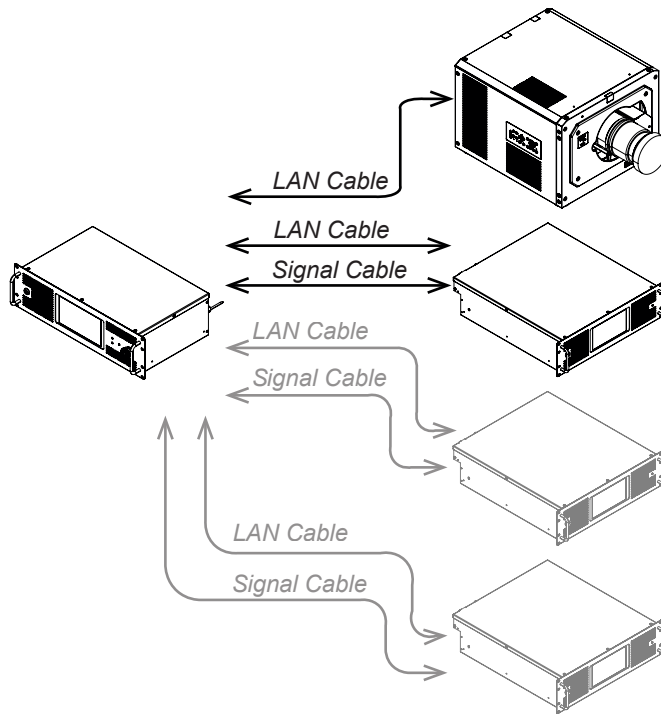

**n:1 System**

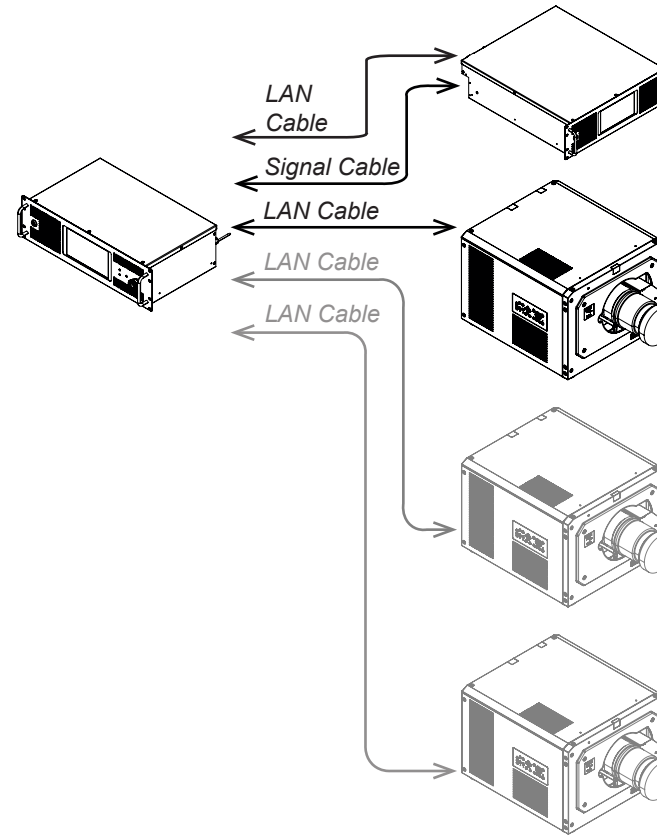

**1:n System**

### Notes

The appropriate cables are supplied with the Satellite MLS. A single signal cable is supplied for each MLS and a single LAN cable is supplied for each MLS and Satellite Head. Use only the cables provided.

A single LAN port **1** is located on the rear of the Satellite Head.

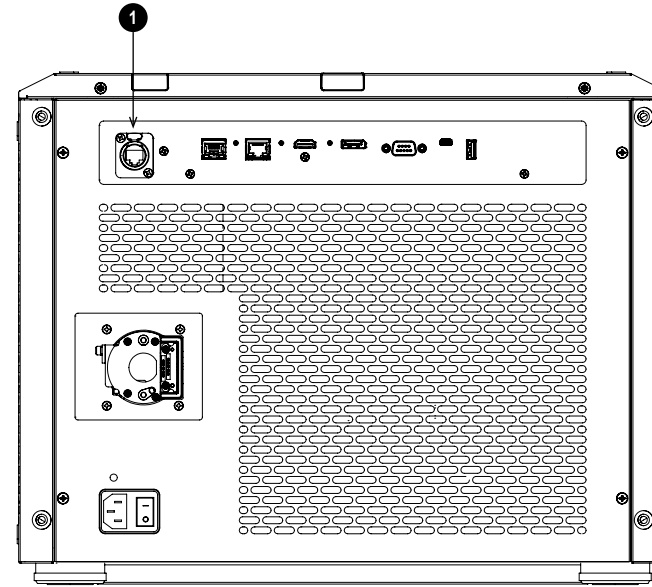

**Satellite Head**

**Notes**

A single signal cable port **2** and a single LAN port **3** are located on the rear of the MLS.

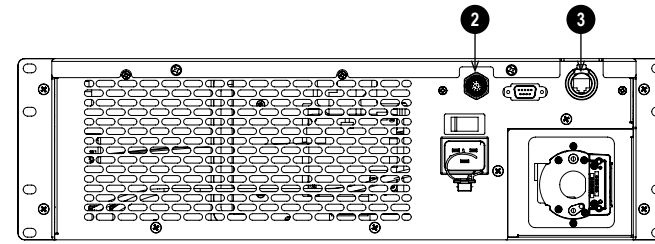

**MLS 10000**

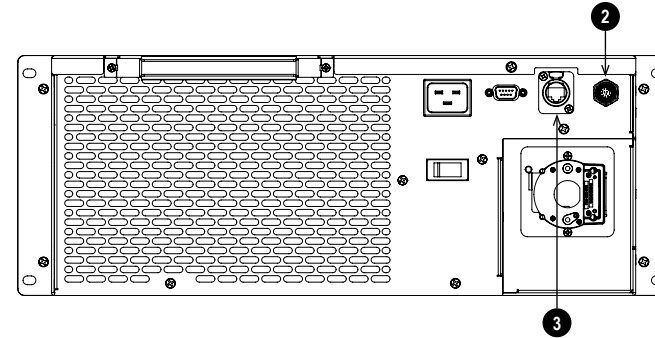

**MLS 20000/MLS 30000**

There are four signal cable ports **4** - **7** and five LAN ports **8** - **12** located on the rear of the SCM.

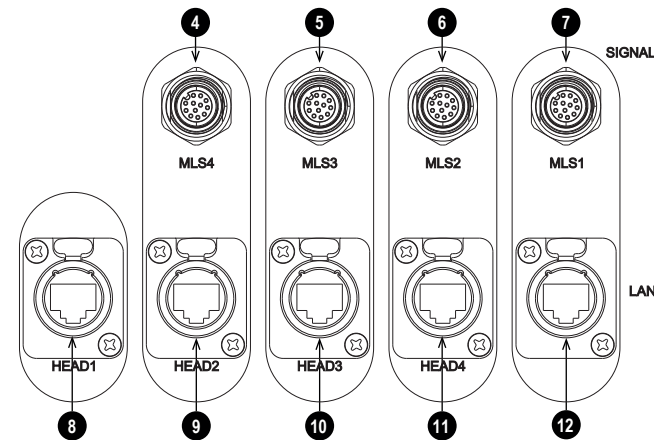

**Notes**

The appropriate cables are supplied with the Satellite MLS. A single signal cable is supplied for each MLS and a single LAN cable is supplied for each MLS and Satellite Head. Use only the cables provided.

## Single Satellite Head and Modular Light Source - 1:1 System

Make the following connections when connecting a system with a single Satellite Head and a single Modular Light source:

1. Connect a signal cable to the MLS and connect it to the MLS 1 socket **1** on the SCM.
2. Connect a LAN cable to the MLS and connect it to the MLS 1 LAN socket **3** on the SCM.
3. Connect a LAN cable to the Satellite Head and connect it to the Head 1 socket **2** on the SCM.

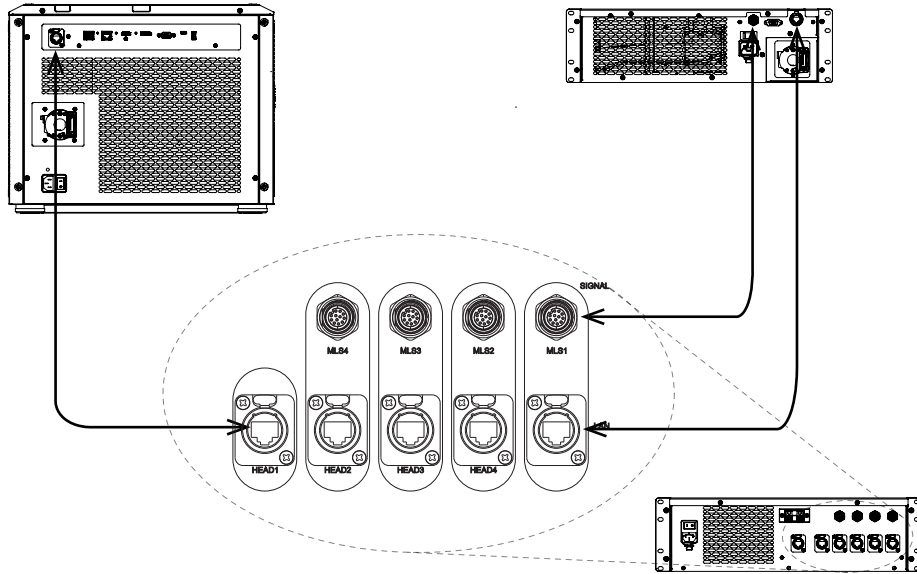

*Example of a 1:1 system configuration*

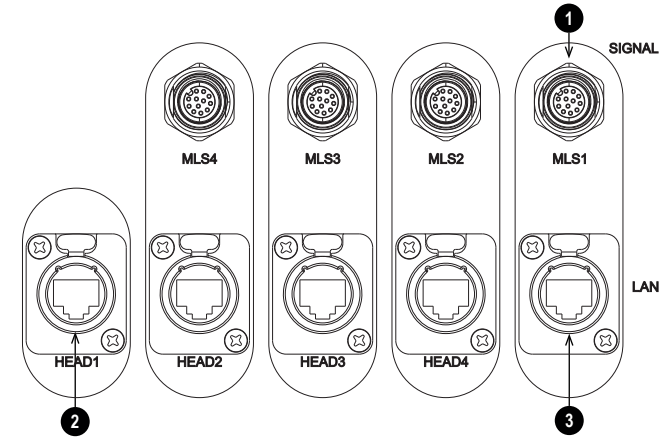

### Notes

## Multiple Modular Light Sources - n:1 System

Make the following connections when connecting multiple MLS:

### 1. First MLS:

- Connect a signal cable to the first MLS and connect it to the MLS 1 socket **3** on the SCM.
- Connect a LAN cable to the first MLS and connect it to the MLS 1 LAN socket **7** on the SCM.

### 2. Second MLS:

- Connect a signal cable to the MLS and connect it to the MLS 2 socket **2** on the SCM.
- Connect a LAN cable to the MLS and connect it to the MLS 2 LAN socket **6** on the SCM.

### 3. Third MLS:

- Connect a signal cable to the third MLS and connect it to the MLS 3 socket **1** on the SCM.
- Connect a LAN cable to the third MLS and connect it to the MLS 3 LAN socket **5** on the SCM.

4. Connect a LAN cable to the Satellite Head and connect it to the Head 1 socket **4** on the SCM.

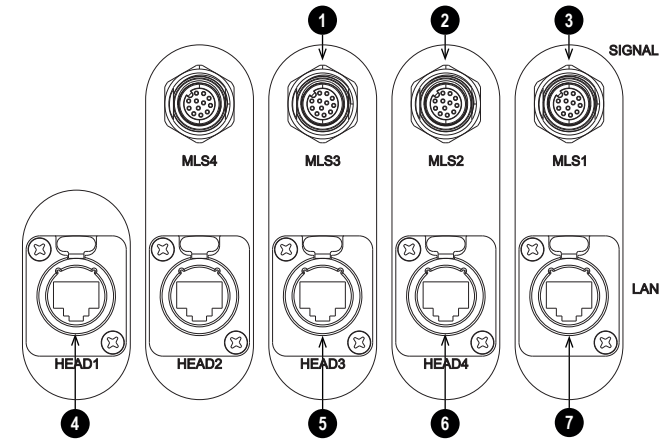

**Notes**

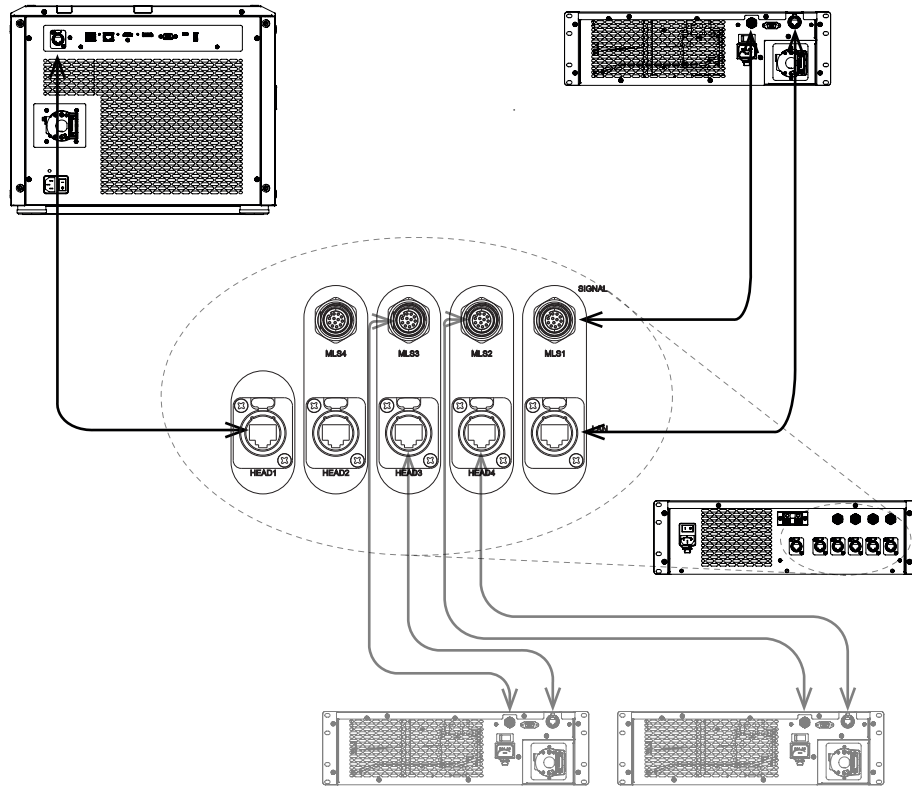

**Example of an n:1 system configuration**

**Notes**

## Multiple Satellite Projector Heads - 1:n System

Make the following additional connections when connecting multiple Satellite Heads:

1. Connect a signal cable to the MLS and connect it to the MLS 1 socket **1** on the SCM.
2. Connect a LAN cable to the MLS and connect it to the MLS 1 LAN socket **6** on the SCM.
3. Connect a LAN cable to the first Satellite Head and connect it to the Head 1 socket **2** on the SCM.
4. Second Satellite Head:
  - Connect a LAN cable to the Satellite Head and connect it to the Head 2 LAN socket **3** on the SCM.
5. Third Satellite Head:
  - Connect a LAN cable to the Satellite Head and connect it to the Head 3 LAN socket **4** on the SCM.
6. Fourth Satellite Head:
  - Connect a LAN cable to the Satellite Head and connect it to the Head 4 LAN socket **5** on the SCM.

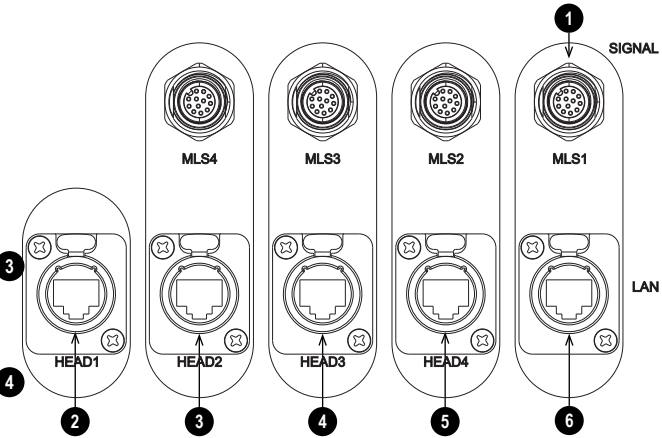

**Notes**

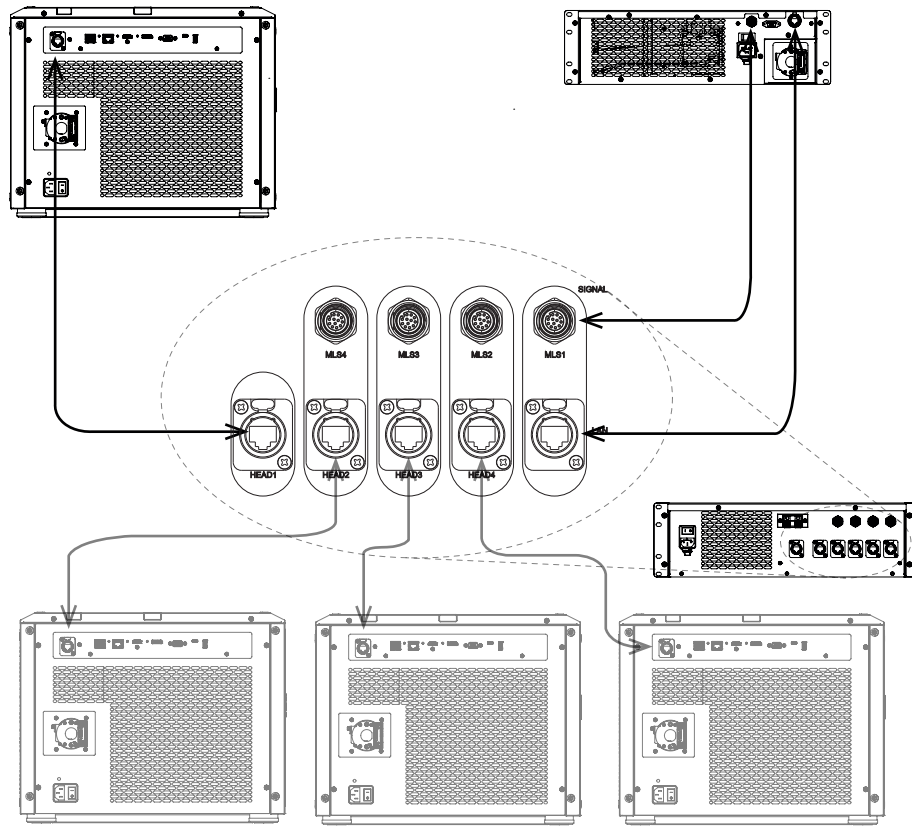

**Example of a 1:n system configuration**

**Notes**

## Power Supply

**Notes**

### AC Power Precautions



**Warning! Death or Serious Injury could occur if the following precautions are ignored**

**Shock Hazard! Only use the AC power cord provided or recommended by the manufacturer**

**Fire & Shock Hazard! Do not operate the product unless the power cord, socket and plug meet local rating standards**

**Do not attempt operation if the AC supply is not within the specified parameters**

**The AC power cord must be inserted into a socket with grounding**

**Disconnect the product from the AC supply before installing, moving, servicing, cleaning or removing covers**

**Do not use an AC power cord that appears damaged**

**Do not overload power sockets or extension cords**

**The projector can operate at 110V or 200V. Voltage selection is automatic. Power off the projector before switching power outlets.**

## Connecting the power supply

1. Firmly push the mains connector into the AC socket **1**

When the cable is plugged in and the power supply is on, the module is OFF until the power button is switched to ON.

When power is applied to the MLS the Laser illumination is not switched on.

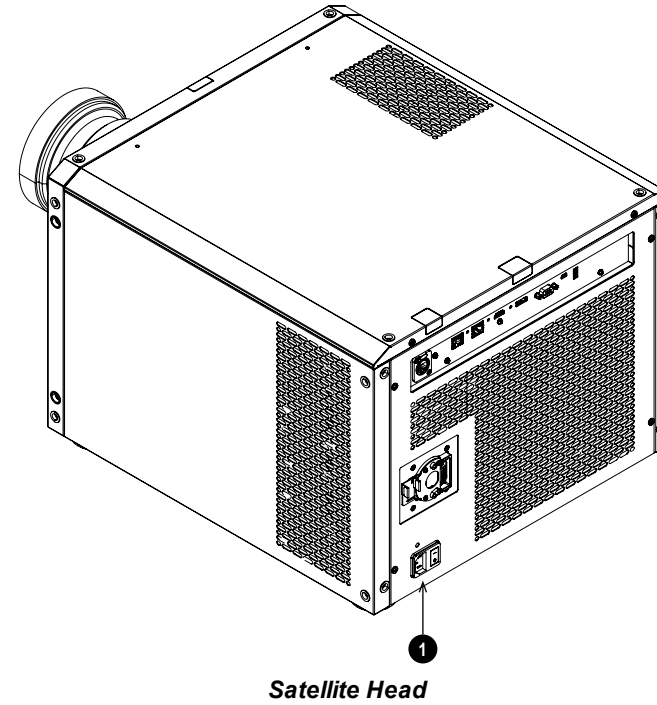

### Notes



Use only the power cable provided.



Ensure that the power outlet includes a ground connection as this equipment **MUST** be earthed.



Handle the power cable carefully and avoid sharp bends. Do not use a damaged power cable.

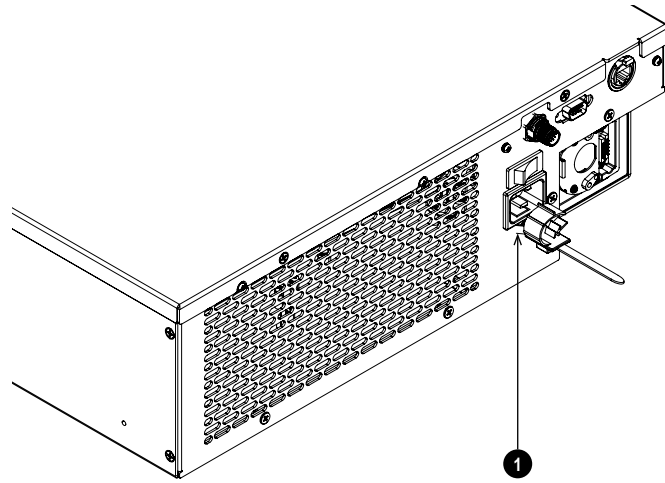

**MLS 10000**

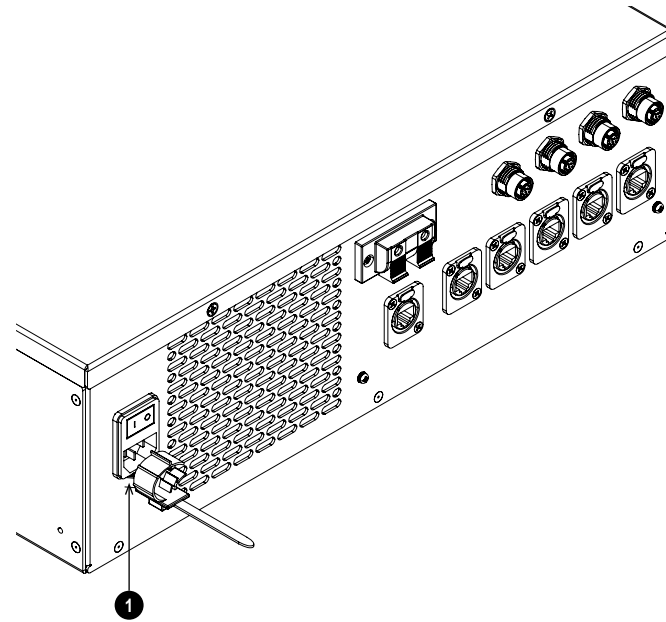

**SCM**

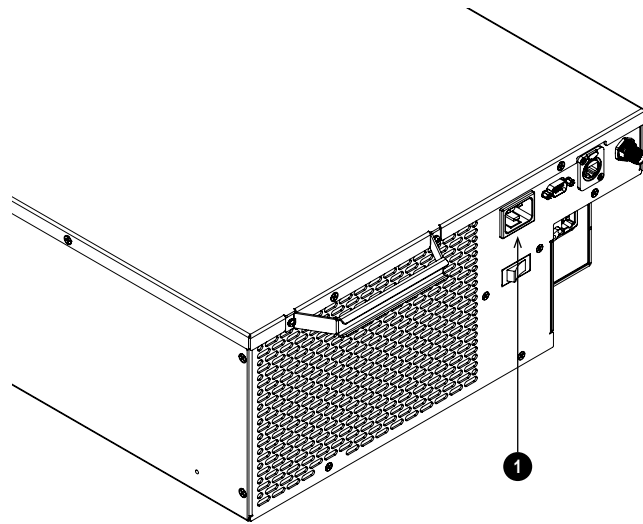

**MLS 20000/MLS 30000**

**Notes**

## Basic Operating Instructions

### Switching the system on

1. Make sure lenses are fitted to each Satellite Head
2. Make sure the Signal, LAN and SLC cables are fitted
3. Make sure power cables are fitted to the Satellite Head, MLS and SCM
4. Make sure the power supply is on
5. Use the power switch located on the power cable socket to apply power to:
  - The Satellite Head
  - The MLS
  - The SCM
6. Insert the laser on key into the laser on switch on the SCM and each MLS and turn to enable
7. Press **ON** on the Remote Control, or;
  - Press **Power** on the Control Panel, or;
  - Tap **Laser On** in the Laser Power Page on the Satellite Control Module touch panel

The POWER indicator begins flashing green as the projector powers up. When the flashing stops, the POWER indicator lights solid green and the Digital Projection logo appears on the screen. The projector is switched on and projecting.

### Switching the projector off

1. Press **OFF** on the Remote Control, or;
  - Press **Power** on the Control Panel, or;
  - Tap **Laser Off** in the Laser Power Page on the Satellite Control Module touch panel
2. Turn the laser on key on the SCM and each MLS to disable.

### Emergency off

In an emergency, press the **Emergency OFF** button on the front of the Satellite Control Module to turn off the Laser Illumination

#### Notes

 See *Operating the system on page 67* for guidance on the projector controls.

 Make sure the projector is fully installed, all interlocks are in place and the laser key switch on the SCM and each MLS are enabled before switching the projector on.

## Interlock reset

In the event of the laser illumination turning off as a result of an Interlock break:

1. Make sure all interlocks are in place. See Interlock Switches on page 26
2. Turn ON the laser illumination. See Switching the system on on the previous page

## Selecting an input signal

1. Connect one or more image sources to the projector.
2. Select the input you want to display:
  - Press one of the input buttons on the remote control or control panel.
  - Alternatively, open the On-screen display (OSD) by pressing **MENU**. Highlight **Input** from the main menu, press **ENTER/OK** and then select an input signal using the **UP** and **DOWN** arrow buttons. Press **ENTER/OK** to confirm your choice.

## Selecting a test pattern

The following test patterns are available: *Off, Native White, Native Black, Native Red, Native Green, Native Blue, Checkerboard, Crosshatch, ColorBar, Aspect Ratio, Grayscale*

Use one of the following methods to display a test pattern:

- Press **TEST** on the remote control.  
Use the **LEFT** and **RIGHT** arrow buttons to cycle through the test patterns.
- Press **MENU** open the OSD. Highlight **Test Patterns** from the main menu, then select a test pattern using the **LEFT** and **RIGHT** arrow buttons.

After the final test pattern, the projector exits test pattern mode and returns to the main image. To view test patterns again, you need to press **TEST** again. If you wish to exit the test patterns before you reach the final one, press **TEST** or **EXIT** at any time.

### Notes



Please refer to the connection guide for details about connecting a signal source. See Signal inputs on page 80

## Adjusting the lens

You can use the following options to adjust the lens:

- Control panel. See Satellite Head Control panel on page 67
- Remote control. See Remote control on page 69
- On screen display (OSD).

## Adjusting the image

### Orientation

This can be set from the **Setup** menu. See on page 1 for guidance.

Highlight **Orientation** and choose from **Front Tabletop**, **Front Ceiling**, **Rear Tabletop**, **Rear Ceiling** and **Auto-front**.

### Picture

Settings such as **Gamma**, **HDR**, **Brightness**, **Contrast**, **Saturation**, **Hue** and **Sharpness** can be set from the **Image** menu. See on page 1 for guidance.

### Notes

## Laser color calibration

The laser colors must be calibrated after installation or after changing MLS within a system:

1. Press **Menu** on the remote control to display the OSD on the screen
2. Use the navigation buttons to highlight the Setup menu and press **OK** to access it
3. Navigate to the System Setting menu and press **OK** to access it
4. Navigate to the Laser Color CAL function and press **OK** to recalibrate the colors.

The calibration will take approximately 30 to 40 minutes to complete.

**System Setting**

Orientation	Front Tabletop
High Altitude	Off
Clock Adjust	▶
Startup Logo	Original
Blank Screen	Logo
PIC Mute	▶
Smear Reduction	Off
Output Frame Rate	60Hz
HDMI Equalizer	Auto
Laser Color CAL	<b>OK</b>
Back	▶

**Notes**

## Operating the system

The system has the following controls:

- Remote control
- Control panel on the Satellite Head
- Touchscreen control panel on the MLS 10000
- Touchscreen control panel on the SCM

### Satellite Head Control panel

- ZOOM**  
Plus and minus buttons zoom in and out.
- FOCUS**  
Plus and minus buttons move the focus in and out.
- LENS SHIFT**  
Arrow buttons move the lens in the specified direction.
- EXIT**  
Exits the current OSD page and enters the level above.
- Arrow buttons & ENTER**  
Press an arrow button to open the keystone menu. Use the arrow buttons to adjust vertical and horizontal keystone. After opening the OSD, use the arrow buttons to highlight menu entries. Press **ENTER** to open or execute the highlighted menu entry.
- MENU**  
Displays and exits the OSD.

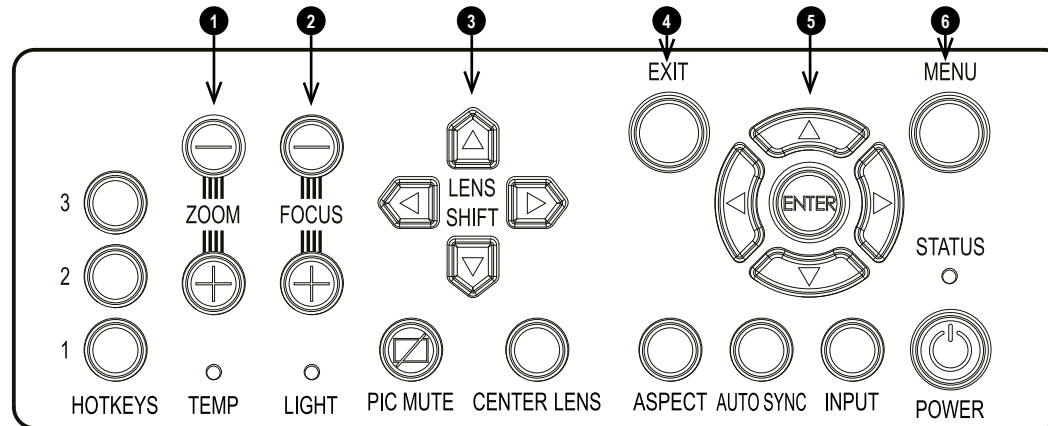

Control Panel

### Notes

*Use the touchscreen control panel on the SCM to access the controls for the MLS 20000 and MLS 30000.*

*Do not make changes to the networking configuration unless you understand what you are doing, or have taken advice from your Network Manager. If you make a mistake, it is possible that you will lose contact with the projector. Always double-check your settings before pressing the APPLY button. Always keep a written note of the original settings, and any changes you have made.*

*Software updates should NOT be carried out except by, or with the supervision of, Digital Projection Service personnel.*

*See Connecting the power supply on page 61.*

*The self-test is running when all the LEDs on the control panel are lit.*

*See Introduction to the OSD on page 86 for full details of how to use the menu system.*

*See Introduction to the MLS 10000 Touchscreen on page 122 for full details of how to use the MLS touchscreen control panel.*

*See Introduction to the SCM Touchscreen on page 1 for full details of how to use the SCM touchscreen control panel.*

**7. HOTKEYS**

User selectable functions. Pre-set functions:

HOTKEY 1 Information

HOTKEY 2 Test Pattern

HOTKEY 3 Lens Load Memory

Additional options: Picture Mode, Ambient Brightness Correction, Freeze, PIP Swap.

**8. PIC MUTE**

Blanks the DMD™ when on. The laser remains on but a black image is displayed.

**9. CENTER LENS**

Centers the lens.

**10. ASPECT**

Changes the aspect ratio.

**11. AUTO SYNC**

Re-synchronises with the current input signal.

**12. INPUT**

Switches to the next input source.

**13. POWER**

Switches the Laser on and off.

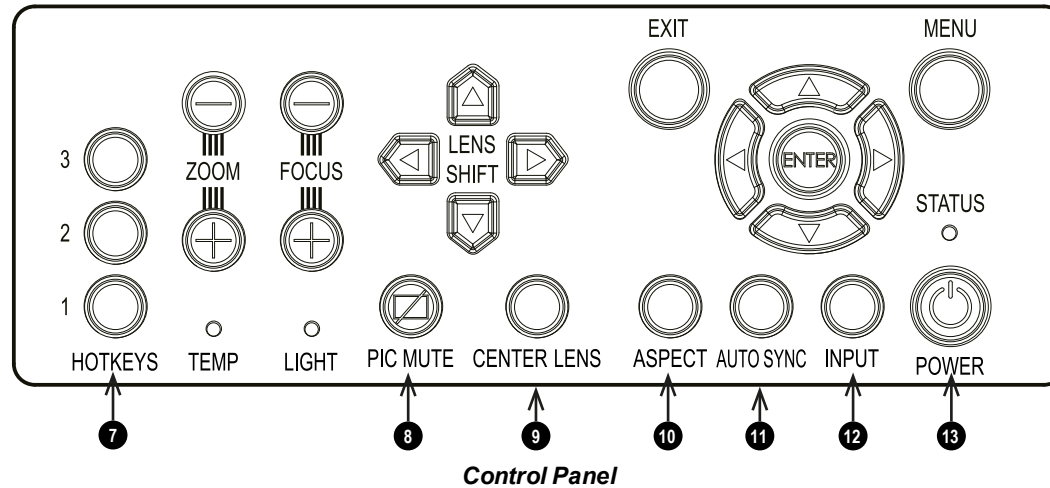

**Notes**

## Remote control

1. **Power ON / OFF**  
Turns power on and off.
2. **Pic Mute OPEN / CLOSE**
  - Press CLOSE to hide the projected image. When off, the laser remains on and a black image is projected.
  - Press OPEN to display the hidden image.
3. **OSD ON / OFF**  
Enable and disable screen timeout messages and control whether to show the OSD during projection.
4. **MENU**  
Access the on screen display (OSD). If the OSD is open, press this button to go back to the previous menu.
5. **Navigation (arrows and OK)**  
**OSD mode:** Navigate through the menus with the arrows, confirm your choice with **OK**.  
**Lens adjustment modes:** See **10** below.
6. **EXIT**  
Go up one level in the OSD. When the top level is reached, press to close the OSD.
7. **DEFAULT**  
When editing a parameter, press this button to restore the default value.
8. **INFO**  
Access information about the projector.

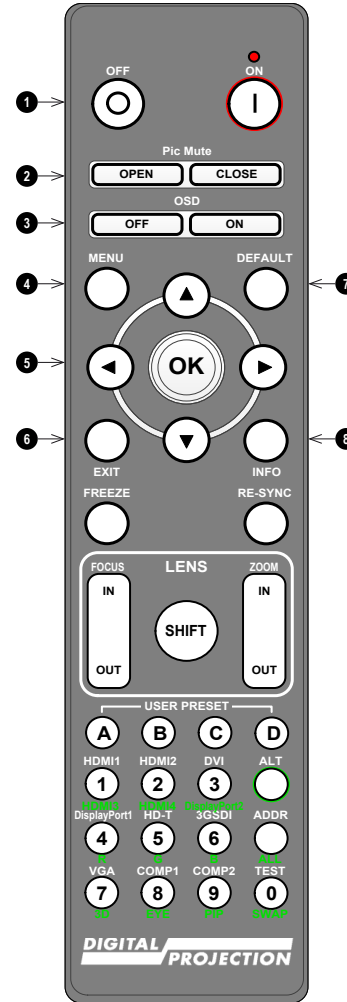

**Remote Control**

## Notes

9. **FREEZE**  
Freeze the current frame.
10. **LENS adjustment**
  - **FOCUS IN / OUT**: adjust focus.
  - **SHIFT**: press and hold this button, then use the OK and Navigation buttons. Press OK to switch between **Shift Adjustment** and **Zoom / Focus Adjustment**. Use the arrows to shift, zoom or focus the lens.
  - **ZOOM IN / OUT**: adjust zoom.
11. **USER PRESET A, B, C, D**  
Load user presets.
12. **RE-SYNC**  
Re-synchronise with the current input signal
13. **ALT**  
Press and hold this button to access alternative functions for other buttons on the remote.
14. **DVI / DisplayPort2 / numeric input 3**  
There is no DVI input on this projector.  
There is no DisplayPort 2 input on this projector.
15. **HDMI 2 / HDMI 4 / numeric input 2**  
Select the HDMI 2 input. There is no HDMI 2 input on this projector.  
There is no HDMI 4 input on this projector
16. **HDMI 1 / HDMI 3 / numeric input 1**  
Select the HDMI 1 input.  
There is no HDMI 3 input on this projector

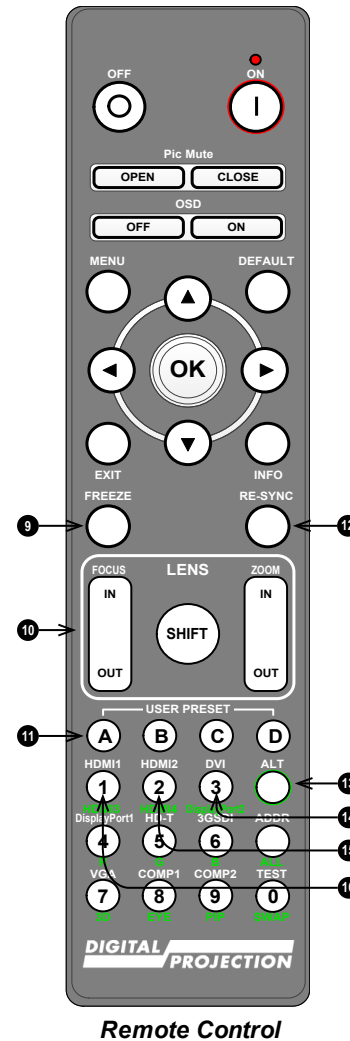

Remote Control

**Notes**

*This projector does not use the following options on the remote:*  
 HDMI2  
 HDMI3  
 HDMI4  
 DisplayPort2  
 DVI

17. **DISPLAYPORT 1 / R / numeric input 4**

Select DisplayPort 1 input.

18. **HD-T / G / numeric input 5**

Select the HDBaseT input.

19. **ADDR / ALL (with red indicator at the top)**

Assign and unassign an IR remote address.

**To assign an IR remote address:**

1. Press and hold this button until the red indicator starts flashing.
2. Release this button and while the red indicator is still flashing, enter a two-digit address using the numeric input buttons. The indicator will flash three times quickly to confirm the change.

**To unassign an address and return to the default address 00:**

1. Press and hold ALT and this button simultaneously until the red indicator flashes to confirm the change.

20. **3GSDI / B / numeric input 6**

There is no 3G-SDI input on this projector.

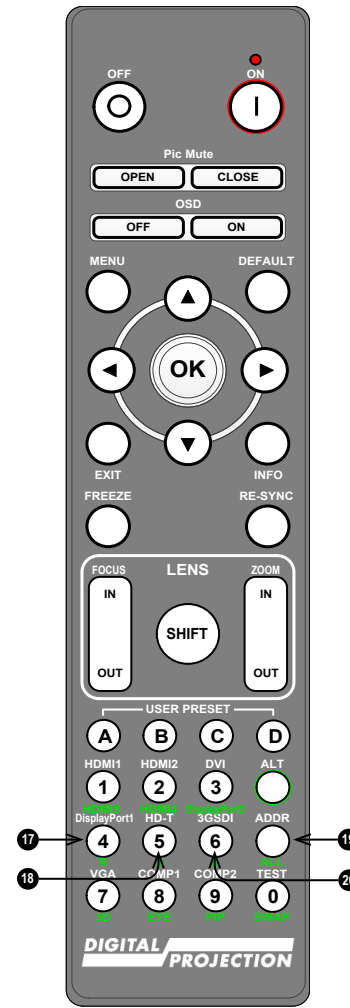

**Remote Control**

**Notes**



*This projector does not use the following options on the remote: 3GSDI*

- 21. **VGA / 3D / numeric input 7**  
There is no VGA input on this projector.
- 22. **COMP1 / EYE / numeric input 8**  
There is no Component 1 input on this projector.
- 23. **TEST / SWAP / numeric input 0**  
Show a test pattern. Press again to show the next test pattern: Off, Native White, Native Black, Native Red, Native Green, Native Blue, Checkerboard, Crosshatch, ColorBar, Aspect Ratio, Grayscale  
When **PIP** mode is on, use this button with **ALT** to swap the main and sub images.
- 24. **COMP2 / PIP / numeric input 9**  
There is no Component 2 input on this projector.  
Use with **ALT** to switch on **Picture In Picture (PIP)** mode.

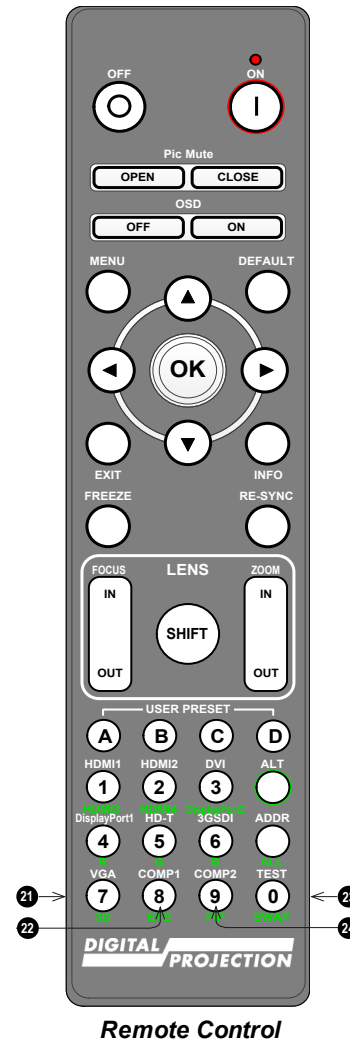

**Notes**

This projector does not use the following options on the remote:

- VGA
- COMP 1
- COMP 2

## Infrared reception

The projector has infrared sensors at the front and rear.

The angle of acceptance is  $40^\circ$ . Make sure that the remote control is within the angle of acceptance when trying to control the projector.

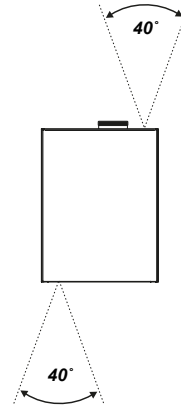

**Notes**

## Module indicators

### Satellite Head

#### 1. TEMP INDICATOR

Off = no problem

Flashing red = temperature error

#### 2. LIGHT INDICATOR

Off = light is switched off

On, amber = light is in forced ECO mode at high temperature

Flashing red (cycles of single flashes) = failure to light up during power up

Flashing red (cycles of double flashes) = unexpected light off while running

On, green = light is switched on

Flashing green (cycles of single flashes) = shutter is on and light source is temporarily off

#### 3. PIC MUTE

Off = the projector is in standby

On, blue = the projector is on, normal projection

Flashing red = the projector is on, picture mute is activated

#### 4. POWER

Off = the projector is switched off

Flashing amber = the projector is cooling down to standby mode

On, amber = the projector is in standby mode

Flashing green = the projector is warming up

On, green = the projector is switched on

#### 5. STATUS

Off = no problem

Flashing amber (cycles of double flashes) = request to calibrate the lens

Flashing green (cycles of double flashes) = the projector is calibrating the lens

Flashing red (cycles of double flashes) = TEC or color sensor error

Flashing red (cycles of four flashes) = fan error

On, red = system error

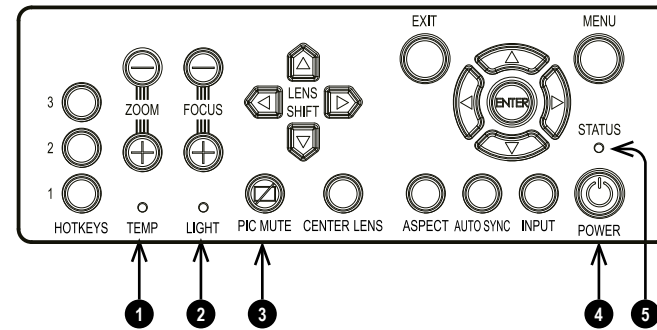

Control Panel

### Notes

1. **LASER ON**  
 Off = laser is off  
 On = laser is on

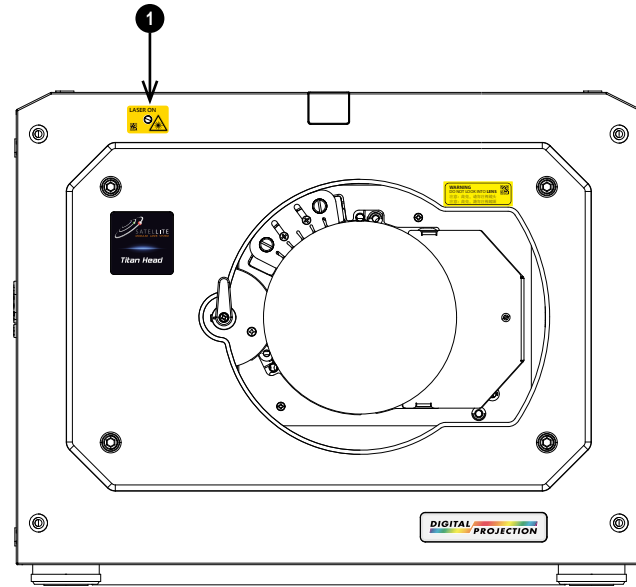

**Satellite Head Front**

**Notes**

*The Laser ON indicator will light up for 30 seconds before the Laser turns on to warn that the laser is about to turn on.*

## 1. STATUS

Off = no problem

Flashing amber = the projector is cooling down to standby mode

Flashing amber (cycles of double flashes) = request to calibrate the lens

On, amber = the projector is in standby mode

Flashing green = the projector is warming up

Flashing green (cycles of double flashes) = the projector is calibrating the lens

On, green = the projector is switched on

Flashing red (cycles of single flashes) = the lens or fiber link is open

Flashing red (cycles of double flashes) = TEC or color sensor error

Flashing red (cycles of four flashes) = fan error

On, red = system error

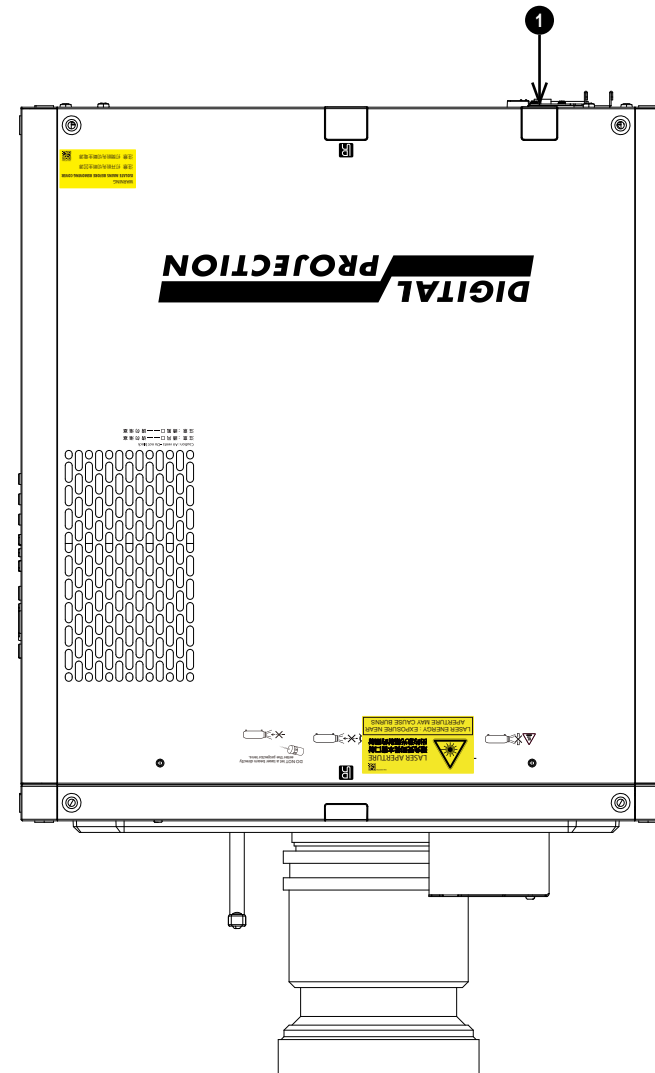

**Satellite Head Top**

**Notes**

## Modular Light Source

### MLS 10000

- LASER ON**  
Off = laser is off  
On = laser is on

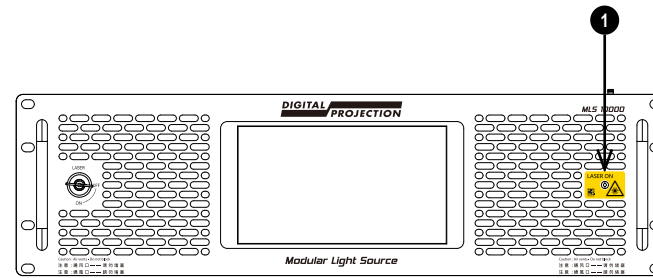

MLS 10000 Front

### MLS 20000 / MLS 30000

- POWER**  
Off = AC power is off  
On = AC power is on
- LASER ON**  
Off = laser is off  
On = laser is on
- STATUS**  
Off = no error  
On = error, see LCD display for details.

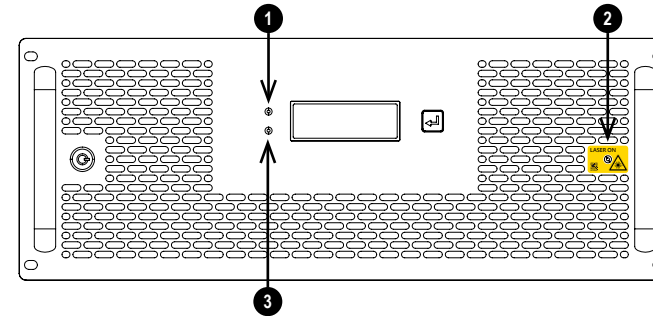

MLS 20000/MLS 30000 Front

## Satellite Control Module

- LASER ON**  
Off = laser is off  
On = laser is on
- POWER GOOD**  
Green = 12V power is good  
Amber = 12V good, but internal power rail has a fault  
Red = 12V PSU not operating within specifications
- INTERLOCK**  
On = Laser system is active and interlock complete  
Off = Laser system is not active

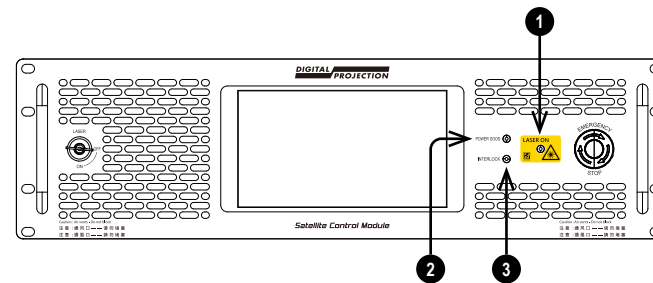

SCM Front

## Notes

The Laser ON indicator will light up for 30 seconds before the Laser turns on to warn that the laser is about to turn on.

The Laser ON indicator will light up for 30 seconds before the Laser turns on to warn that the laser is about to turn on.

The Laser ON indicator will light up for 30 seconds before the Laser turns on to warn that the laser is about to turn on.

This page is intentionally left blank

# *Satellite Titan WUXGA 120Hz*

Digital Video Projector

CONNECTION GUIDE



A brand of  **DELTA**

## Signal inputs

### Digital inputs and outputs

1. **Ethernet**  
Provides LAN connectivity via an ethernet cable.
2. **HDBaseT/LAN**  
Receives digital signal from HDBaseT-compliant devices. Cat 6A cable is recommended.
3. **HDMI**  
HDMI 2.0 inputs supporting HDCP 2.2. Connect an **HDMI** cable to the connector.
4. **DisplayPort**  
DisplayPort 1.2 input. Connect a DisplayPort cable to the connector. Supports sources up to 4K resolution at 60 Hz and 2048 x 1080 at 120Hz.
5. **USB**  
USB 5V / 1.5A output. Connect a USB cable to supply power to an external device.

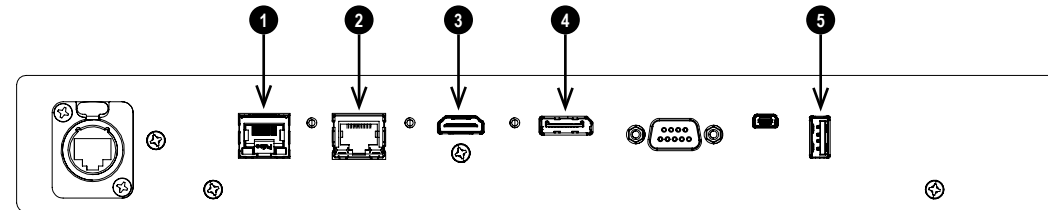

**Satellite Head Connection Panel**

### Notes

*For simultaneous HDBaseT and LAN connectivity, a third-party distribution product can be utilised to combine HDBaseT video stream with LAN connection for delivery to the projector.*

*See 2D formats on page 164 for information about supported 2D signal input modes.*

## EDID on the DisplayPort, HDMI, and HDBaseT inputs

If you are using a computer graphics card or another source that obeys the EDID protocol, the source will automatically configure itself to suit the capability of the projector.

Otherwise refer to the documentation supplied with the source to manually set the resolution to the DMD™ resolution of the projector or the nearest suitable setting. Switch off the source, connect to the projector, then switch the source back on again.

## Using DisplayPort / HDMI / HDBaseT switchers with the projector

When using a DisplayPort/HDMI/HDBaseT source switcher with the projector, it is important to set the switcher so that it passes the projector EDID through to the source devices.

If this is not done, the projector may not be able to lock to the source or display the source correctly as its video output timings may not be compatible with those of the projector. Sometimes this is called transparent, pass-through or clone mode. See your switcher's manual for information on how to set this mode.

1. Sources
2. Switcher
3. Satellite Head

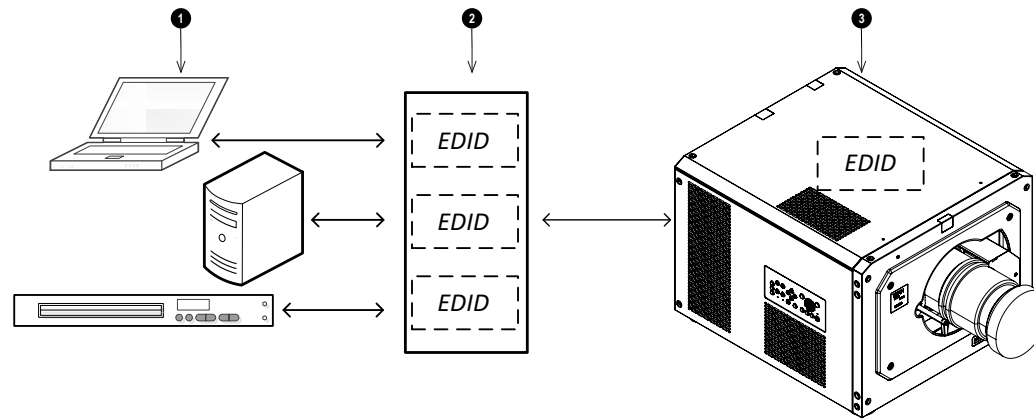

***The EDIDs in the switcher should be the same as the one in the projector.***

## Notes

## Control connections

1. **Ethernet**  
This system is linked via a series of Ethernet connections. See Connecting the Signal and LAN cables on page 52
2. **RS232**  
This port is for servicing purposes only.
3. **Service**  
This port is for servicing purposes only.
4. **Ethernet**  
This system can be controlled via an Ethernet connection. Use an Ethernet cable to connect the SCM to your computer.

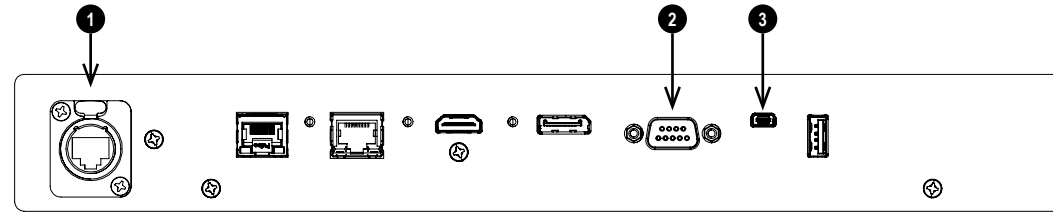

Satellite Head Connection Panel

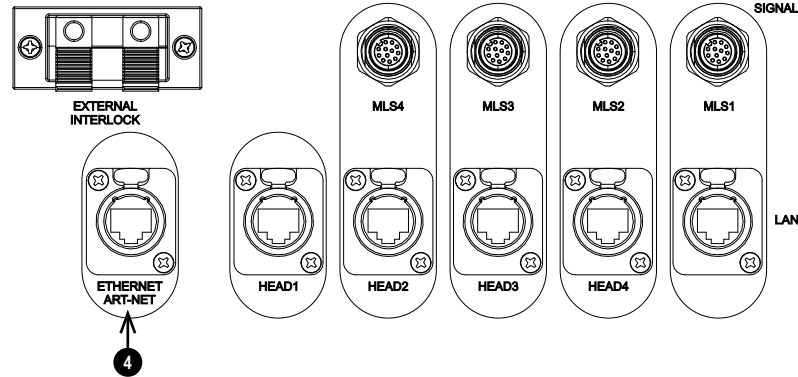

SCM Connection Panel

### Notes

See "Connecting the Signal and LAN cables" on page 52 and "Connecting the Satellite Link Cable" on page 49 for guidance on setting up the connections between each Satellite Head, MLS and SCM.

For a list of all commands used to control the projector via LAN, see the **Protocol Guide** (available separately).

Only one control connection should be used at any one time.

With an Ethernet connection the system can serve a web page offering status and controls. See Served web pages on page 173 for guidance on accessing and using the served web pages.

**Projector Controller** is available for download, free of charge, from the Digital Projection website.

## LAN connection examples

The projector's features can be controlled via a LAN connection, using Digital Projection's **Projector Controller** application or a terminal emulation program.

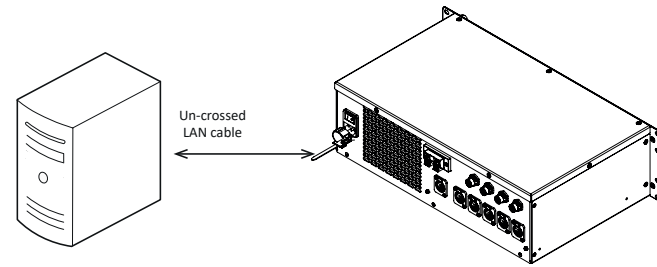

### Notes

*With an Ethernet connection the system can serve a web page offering status and controls. See Served web pages on page 173 for guidance on accessing and using the served web pages.*

***Projector Controller** is available for download, free of charge, from the Digital Projection website.*

This page is intentionally left blank

# *Satellite Titan WUXGA 120Hz*

Digital Video Projector

ON SCREEN DISPLAY (OSD) OPERATING GUIDE



A brand of  **DELTA**

## Introduction to the OSD

This section describes the operation of the OSD.

### Opening the Menu

Use the projector control panel or the remote control to open the on-screen display (OSD). On either device:

1. Press the **MENU** button.  
The OSD opens showing the list of available menus

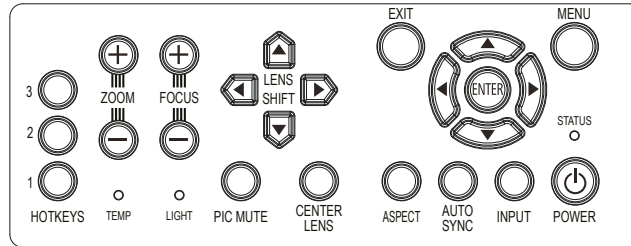

**Projector control panel**

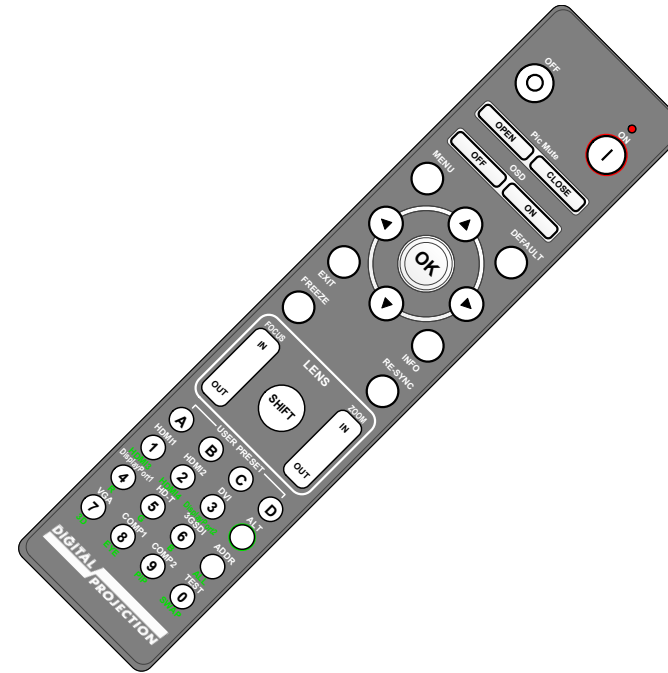

**Remote control**

### Opening a submenu

1. Move up and down the list using the **UP** and **DOWN** arrow buttons.
2. Press **ENTER** on the control panel or **OK** on the remote control to open a submenu.

This guide refers to the above two buttons as **ENTER/OK**.

**Notes**

## Exiting menus and closing the OSD

To go back to the previous page:

1. Press **EXIT**.

To close the OSD:

1. Press **MENU**.

Or:

1. Go back to the top level menu
2. Press **EXIT**.

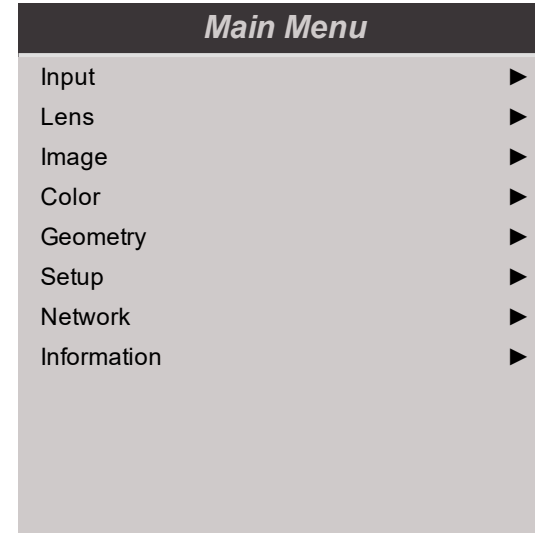

*On Screen Display (OSD): Top Level Menu*

## Inside a menu

When you open a menu, the page consists of the following elements:

- Title bar at the top shows which menu you have accessed.
- Highlighted item
- Available and unavailable items Unavailable items appear a pale gray color. Whether an item is available may depend on other settings.
- The text or symbol to the right of an item shows whether the item:
  - has a value that can be changed (the current value is shown)
  - opens a sub-menu (an arrow button is displayed)
  - executes a command (the space to the right of the item is blank).

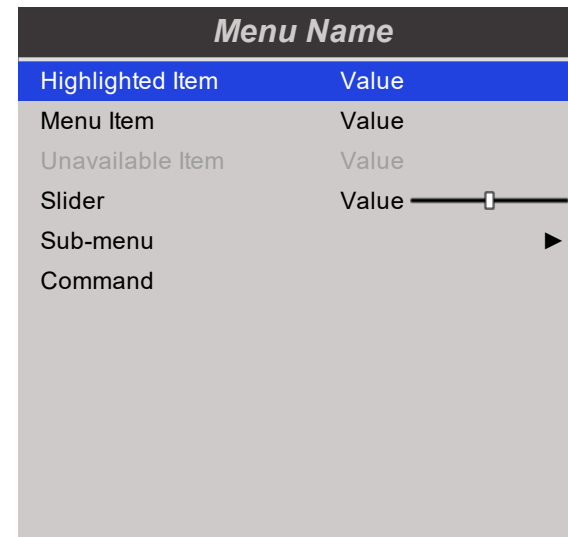

*Inside a menu*

## Notes

 *The highlighted item has blue background.*

## Accessing sub menus

Use the **UP** and **DOWN** arrow buttons to highlight the sub-menu, then press **ENTER/OK**.

## Executing commands

Some items contain a command, such as an OK button.

Press **ENTER/OK** to execute the highlighted command.

You may be asked for confirmation. Use the **ENTER/OK** to confirm, or **EXIT** to cancel.

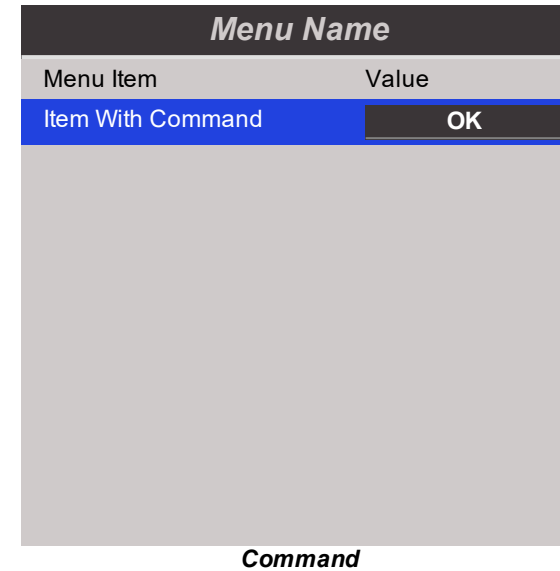

**Notes**

## Editing projector settings

If the highlighted menu item contains a list of values to choose from, you can change the value by doing the following:

1. Highlight the menu item and press **ENTER/OK**.
2. In the list of values that opens, use the **UP** and **DOWN** arrow buttons to highlight a value, then press **ENTER/OK** again to select the highlighted value.

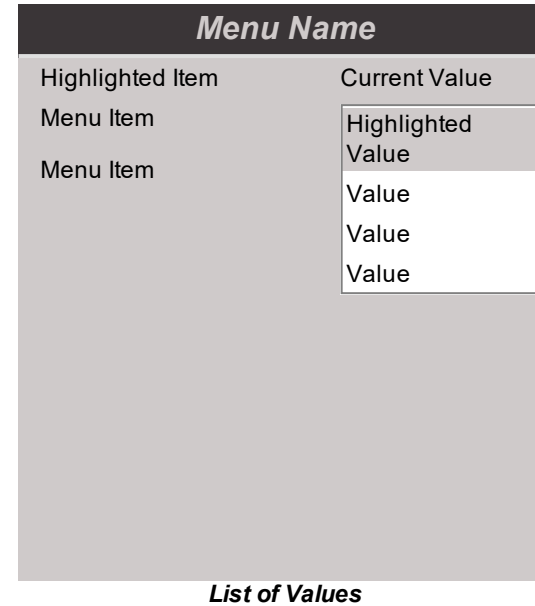

## Using a slider to set a value

Some parameters show a slider. To set such a parameter:

1. Press the **LEFT** or **RIGHT** arrow button, or **ENTER/OK**. The arrow buttons will open the slider and adjust the value at the same time. **ENTER/OK** will open the slider without altering the initial value.
2. Use the **LEFT** and **RIGHT** arrow buttons to move the slider.
3. When ready, press **RETURN** to exit the slider and return to the menu.

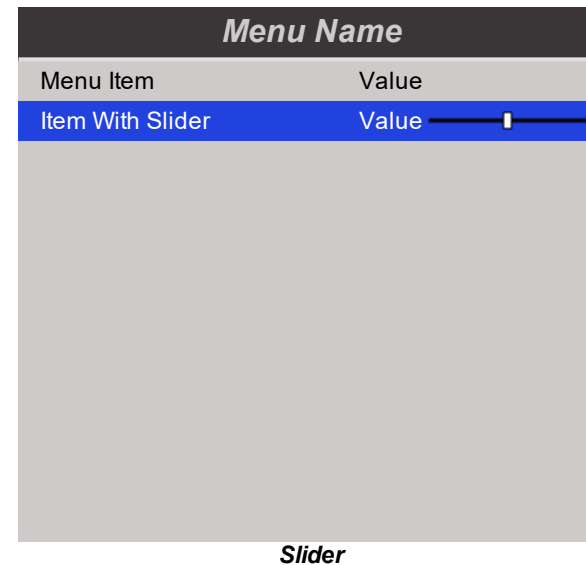

### Notes

 Some menu items may be unavailable due to settings in other menus. Unavailable menu items appear gray

 Please wait for any value changes to be applied

## Editing numeric values

Some parameters take numeric values without using sliders - for example, color matching values or IP addresses.

1. Use the **UP** and **DOWN** arrow buttons to highlight the row containing the numeric field you wish to edit.
2. Press **ENTER/OK** to enter edit mode. A numeric field in edit mode is white text on blue background.
3. In edit mode:
  - Use the **UP** arrow button to increase the numeric value.
  - Use the **DOWN** arrow button to decrease the numeric value.
4. Use the **LEFT** and **RIGHT** arrow buttons to edit the next or previous numeric fields within the same row.
5. Once ready, press **ENTER/OK** to exit edit mode.

<i>Data</i>	
Row	x: 0.658 y: 0.339
Highlighted Row	x: 0.315 y: 0.662
Row	x: 0.146 y: 0.043
Row	x: 0.276 y: 0.283

## Notes

## Using the projector

### Main Menu

- **Input, Lens, Image, Color, Geometry, Setup, Network, Information.**  
Press **ENTER/OK** to open these menus and access various settings.

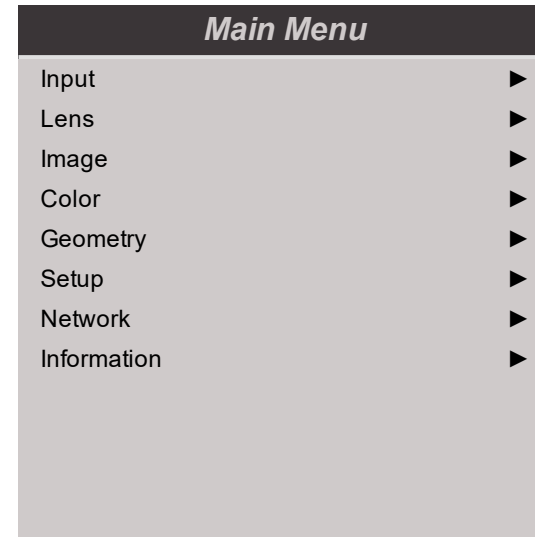

### Input

- **Input**  
Press **ENTER/OK** to open the list of available inputs. Use the **UP** and **DOWN** arrow buttons to select an input from the list, then press **ENTER/OK** to confirm your choice. Press **EXIT** to return to the main menu.
- **Test Pattern**  
Off, Native White, Native Black, Native Red, Native Green, Native Blue, Checkerboard, CrossHatch, ColorBar, Aspect Ratio, Greyscale.  
Use the **LEFT** and **RIGHT** arrow buttons to switch between values.
- **Resync**  
Press **ENTER/OK** to force the projector to resynchronize with the current input
- **Auto Source**  
If this setting is **On**, the projector will automatically search for an active input source.
- **EDID Mode.**  
Press **ENTER/OK** to open this sub menu.
- **Main Menu**  
Go back to the main menu.

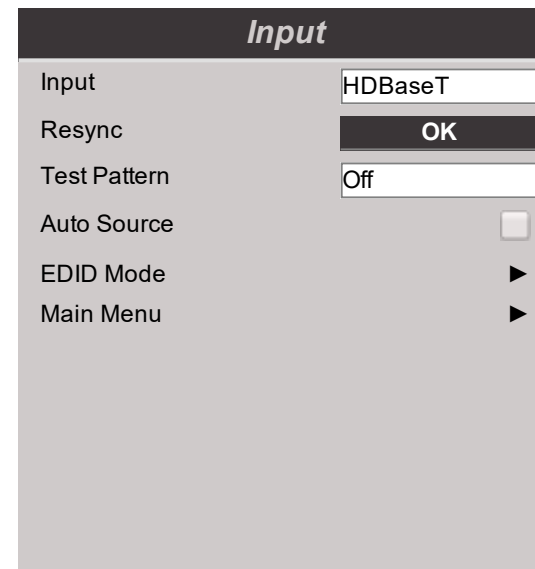

### Notes



See Signal inputs on page 80 for information about the available inputs and connections.



Selecting a test pattern hides the OSD. Press **EXIT** to hide the test pattern, and then press **MENU** to show the OSD

### EDID Mode

Each signal input type is available in the menu. Select the appropriate frame rate and display resolution for each input.

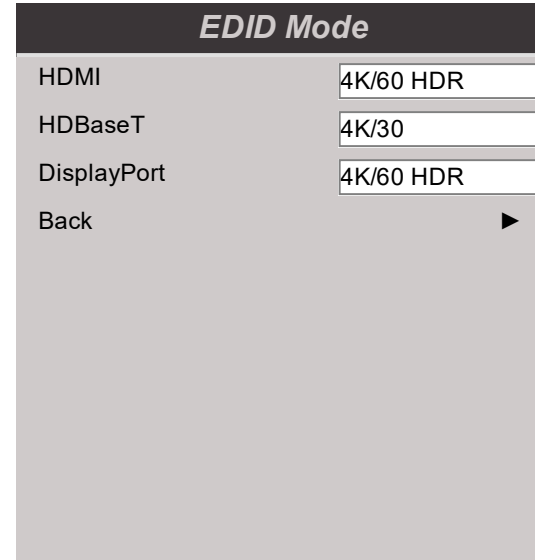

### Notes

## Lens

- **Lens Lock**  
When this feature is **On**, all other Lens menu items are disabled.
- **Center Lens**  
Centers the lens.
- **Lens Memory**  
Opens a sub-menu, see next page.
- **Main Menu**  
Go back to the main menu.

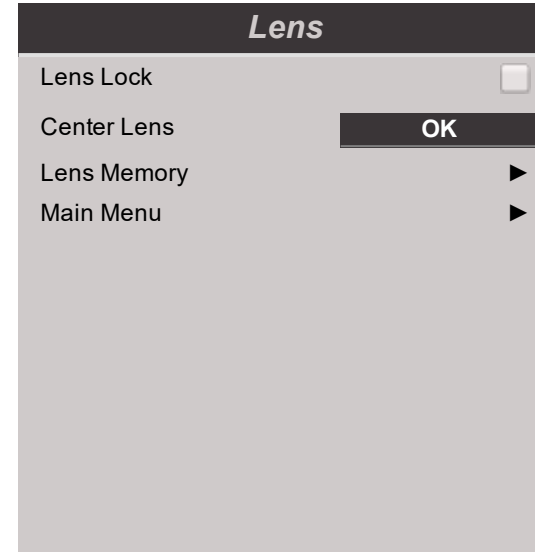

## Lens Memory

This menu allows you to load, save and delete up to ten lens presets, containing position, zoom, focus and shift adjustment information.

For example, if using different screen sizes and aspect ratios, you can save zoom, focus and positioning for each screen size and aspect ratio in a dedicated preset.

Use **Clear Memory** to delete a memory preset if you need to save a new combination of lens settings in its place. Overwriting a saved memory preset is not possible.

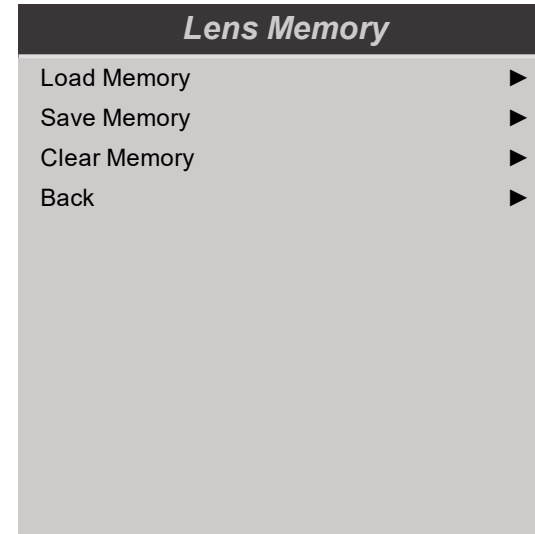

## Notes

***Lens Load Memory***

Memory 1	<b>OK</b>
Memory 2	<b>OK</b>
Memory 3	<b>OK</b>
Memory 4	<b>OK</b>
Memory 5	<b>OK</b>
Memory 6	<b>OK</b>
Memory 7	<b>OK</b>
Memory 8	<b>OK</b>
Memory 9	<b>OK</b>
Memory 10	<b>OK</b>
Back	▶

***Lens Save Memory***

Memory 1	<b>OK</b>
Memory 2	<b>OK</b>
Memory 3	<b>OK</b>
Memory 4	<b>OK</b>
Memory 5	<b>OK</b>
Memory 6	<b>OK</b>
Memory 7	<b>OK</b>
Memory 8	<b>OK</b>
Memory 9	<b>OK</b>
Memory 10	<b>OK</b>
Back	▶

***Lens Clear Memory***

Memory 1	<b>OK</b>
Memory 2	<b>OK</b>
Memory 3	<b>OK</b>
Memory 4	<b>OK</b>
Memory 5	<b>OK</b>
Memory 6	<b>OK</b>
Memory 7	<b>OK</b>
Memory 8	<b>OK</b>
Memory 9	<b>OK</b>
Memory 10	<b>OK</b>
Back	▶

**Notes**

## Image

- **Gamma**

Choose a de-gamma curve from **1.0, 1.8, 2.0, 2.2, 2.35, 2.5, DICOM**

Used correctly, the **Gamma** setting can improve contrast while maintaining good details for blacks and whites.

If excess ambient light washes out the image and it is difficult to see details in dark areas, lower the **Gamma** setting to compensate. This improves contrast while maintaining good details for blacks. Conversely, if the image is washed out and unnatural, with excessive detail in black areas, increase the setting.

**DICOM** is a simulated DICOM display, which can be used for training applications.

- **HDR**

Choose from **Off, Auto, PQ-400, PQ500, PQ1000** and **HLG**.

HDR (High Dynamic Range) is a form of gamma developed to create more realistic experience when viewing images delivered using this format, such as scenes with bright sunlight. Unlike traditional gamma, HDR is not device or installation independent. HDR content will come with a recommended brightness regardless of screen size.

For best results, as a guideline, the following screen sizes are suggested.

HDR Screen sizes		Screen width (cm)					
Model	Lumens	300 NIT	400 NIT	500 NIT	600 NIT	1000 NIT	4000 NIT
Titan Satellite WUXGA 120	10,000	412	357	319	291	226	113
Titan Satellite WUXGA 120	20,000	583	505	451	412	319	160
Titan Satellite WUXGA 120	27,000	714	618	553	505	391	195

HDR options should only be used with media players and sources equipped with HDR capability and outputting HDR content.

Perceptual Quantizer (PQ) is the digitizing concept for capture and display and provides metadata to enable the display to understand the coding of the content.

The NIT numbers relate to the brightness of the viewing conditions in NIT. NIT is the unit of brightness measurement for monitors and LED walls that emit light rather than reflect it such as a projection screen. However it is a reference to the brightness you would choose for a given environment.

**HLG** is High Dynamic Range – hybrid-log-gamma. This is a broadcast version of HDR for live TV and events.

- **Ambient Brightness Correction**

Choose from; **Off, BC1, BC2, BC3, BC4, BC5, BC6**

This adjusts brightness, contrast, saturation, hue and sharpness settings to levels that are pre-configured for different levels of ambient light.

- **Brightness, Contrast, Saturation, Hue, Sharpness**

Highlight the setting you wish to edit, and then press **ENTER/OK**, or the **LEFT** or **RIGHT** arrow button to open the slider.

Use the **LEFT** and **RIGHT** arrow buttons to adjust the slider.

Press **EXIT** to close the slider and return to the menu, or **MENU** to close the slider and return to the projected image.

- **Noise Reduction**

Choose a level of noise reduction from **Off, Low, Middle** and **High**.

- **Advanced**

Opens a sub-menu.

- **Main Menu**

Go back to the main menu.

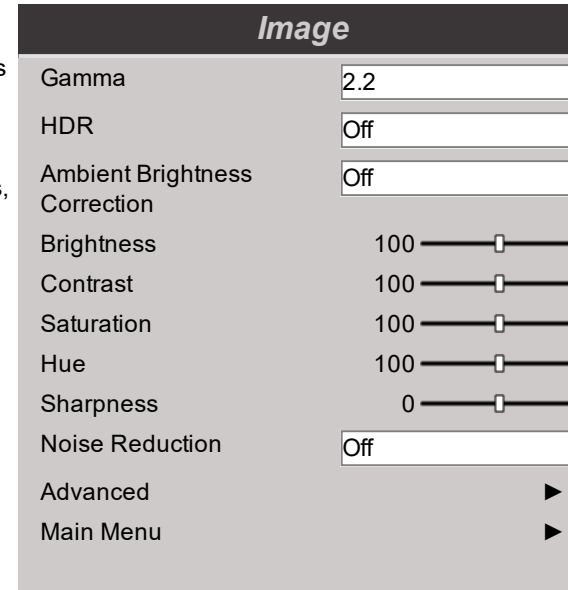

## Notes

 This product includes a DICOM simulation feature intended for training and other non-medical diagnosis purposes.

 Selecting a HDR setting will disable the Gamma setting. If the HDR setting is Auto, the Gamma setting is only disabled when the image source is HDR.

 The HDR AUTO setting is only available when the incoming signal is HDR capable.

## Advanced

- **Freeze**  
Freezes the current frame.
- **Ambient Brightness Correction**  
Choose from; Off, BC1, BC2, BC3, BC4, BC5, BC6  
This adjusts brightness, contrast, saturation, hue and sharpness settings to levels that are pre-configured for different levels of ambient light.
- **Dynamic Contrast**  
Tick to activate. Will automatically adjust the contrast level according the displayed image.
- **Light Off Timer**  
When **Dynamic Contrast** is **On**, the **Light Off Timer** will define if laser light source will turn off after a period of time has passed. The options are: **0.5, 1.0, 1.5, 2.0, 3.0, 4.0** seconds.
- **Main Menu**  
Go back to the main menu.

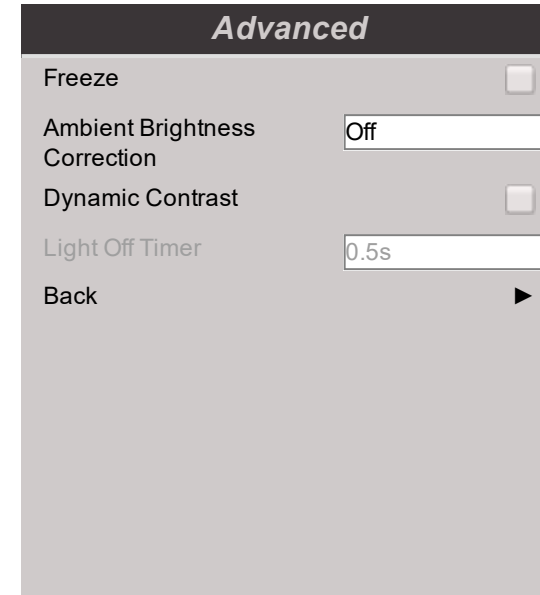

## Notes

## Color

### Notes

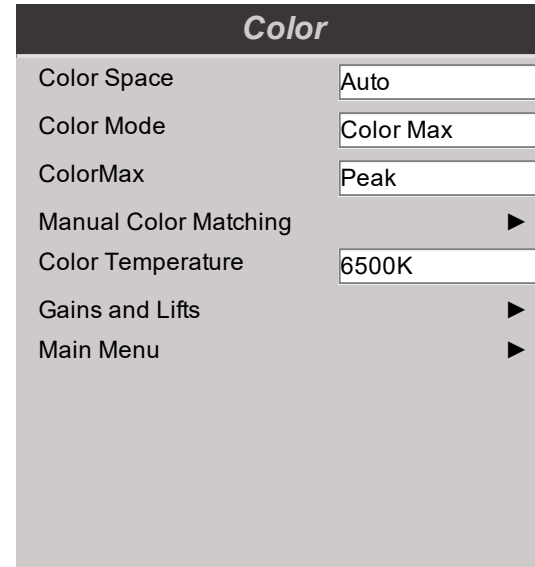

## Color Space

In most cases, the Auto setting determines the correct colorspace to use. If it does not, you can choose a specific colorspace:

Choose from **Auto**, **YPbPr**, **YCbCr**, **RGB PC** and **RGB Video**.

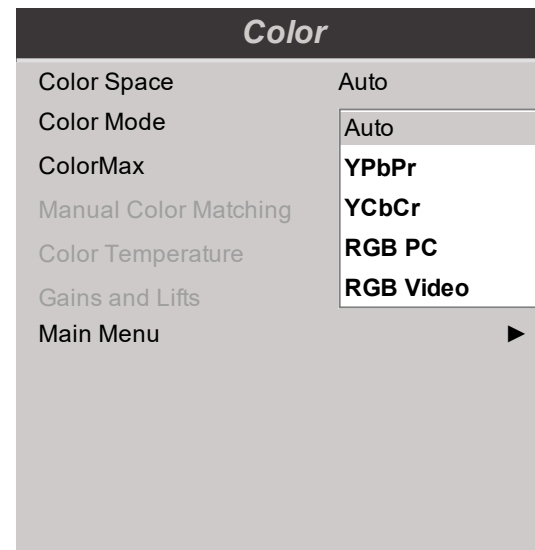

## Color Mode

The projector can work in the following color modes:

- **ColorMax**
- **Manual Color Matching**
- **Color Temperature**
- **Gains and Lifts**

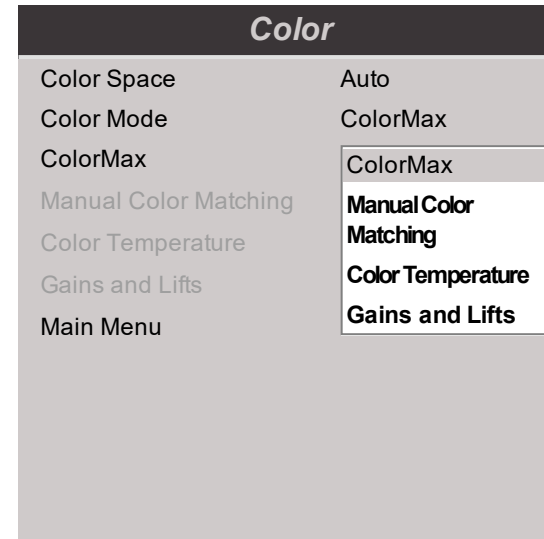



### Notes

 Only one color mode can be selected at a time. Settings used by the other color modes are disabled.

## ColorMax

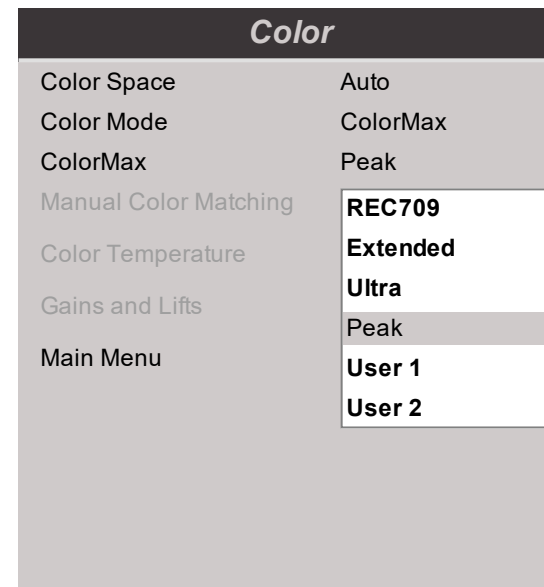
1. Set **Color Mode** to **ColorMax**.
2. Navigate to the **ColorMax** setting.
3. Choose from **REC709, Extended, Ultra, Peak, User 1** and **User 2**. **User 1** and **User 2** are user-defined color gamuts set via the **Setup > ColorMax** menu.



 See Setup menu on page 1 for further information about setting up the **User 1** and **User 2** color gamuts.

## Manual Color Matching

1. Set **Color Mode** to **Manual Color Matching**.
2. Open the **Manual Color Matching** submenu.

Here you can do the following:

- Adjust **Hue, Saturation and Gain** settings for each individual color to improve the color balance of the projected image.
- Adjust white balance RGB values.
- Reset all values.

### Manual Color Matching

Red	▶
Green	▶
Blue	▶
Yellow	▶
Cyan	▶
Magenta	▶
White Balance	▶
Reset	
Back	▶

### Manual Color Matching - Red

Hue	500	▬	▬
Saturation	500	▬	▬
Gain	500	▬	▬

### Manual Color Matching - White Balance

Red	500	▬	▬
Green	500	▬	▬
Blue	500	▬	▬

## Notes



See Color matching parameters explained on the next page for more details about the Hue, Saturation and Gain settings.

### Color matching parameters explained

The levels of hue, saturation and gain in the Manual Color Matching menu change the color values in the following ways:

1. **Hue** Specifies the position of each color (red, yellow, green, cyan, blue and magenta) relative to its neighboring colors.
2. **Saturation** Specifies the level of white in each color (i.e. how “pale” each color is).
3. **Gain** Controls the amount of light that goes into each color, i.e. the lowest gain would produce black.

**Notes**

## Color Temperature

1. Set **Color Mode** to **Color Temperature**.
2. Navigate to the **Color Temperature** setting. Choose a value from **3200K** (warmer) to **9300K** (cooler) or **Native** (no correction).

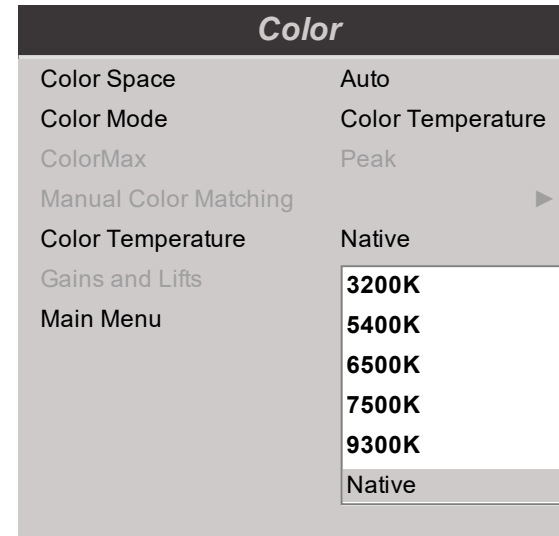

## Notes

## Gains and Lifts

1. Set **Color Mode** to **Gains and Lifts**.
2. Open the **Gains and Lifts** submenu.

Lifts allow you to adjust black levels of individual colors, while gains adjust the bright part of the scale.

Set the sliders as required

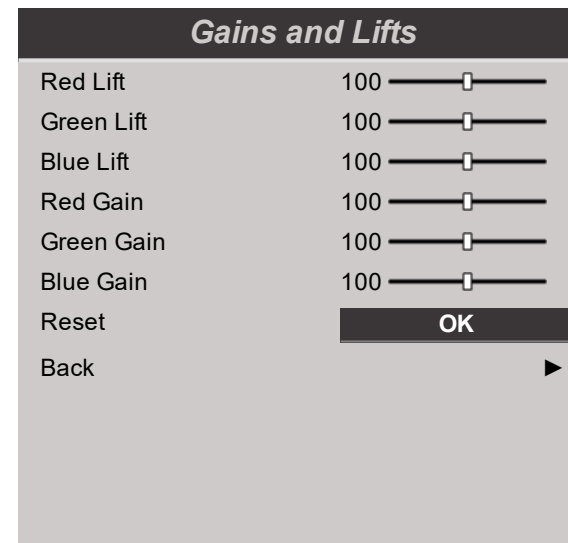

## Geometry

This menu allows you to compensate for image distortions caused by an unusual projection angle or irregular screen surface.

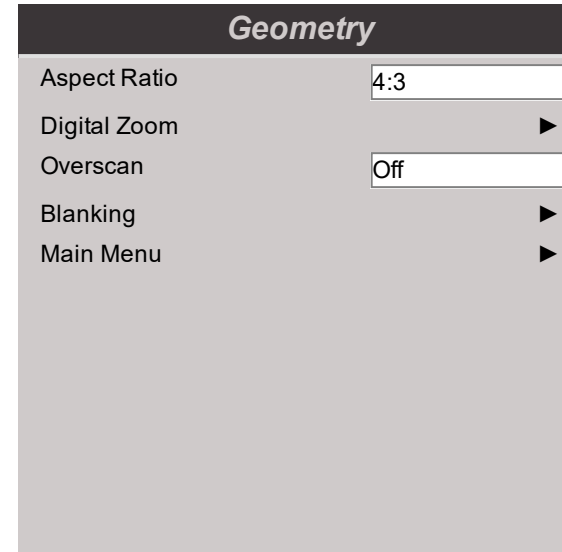

## Aspect Ratio

This feature defines the aspect ratio of the source. Use the **Setup > Screen Setting** to define the screen aspect ratio.

If you choose a preset aspect ratio from here, it will give you the best fit for your selection.

Choose from:

- 5:4
- 4:3
- 16:10
- 16:9
- 1.88
- 2.35
- TheaterScope
- Source
- Unscaled

## Notes



*Image scaling and aspect ratio are also influenced by **Setup > Screen Setting**.*



*See **TheaterScope** setting on the facing page for further information about the **TheaterScope** aspect ratio.*

## Theaterscope setting

The **TheaterScope** setting is used in combination with an anamorphic lens to restore 2.35:1 images packed into a 16:9 frame. Such images are projected with black lines at the top and bottom of the 16:9 screen to make up for the difference in aspect ratios.

Without an anamorphic lens and without the TheaterScope setting applied, a 16:9 source containing a 2.35:1 image looks like this:

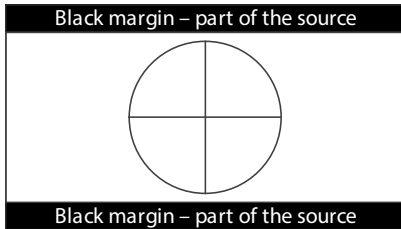

If we change the setting to TheaterScope, the black lines will disappear but the image will stretch vertically to reach the top and bottom of the DMD™:

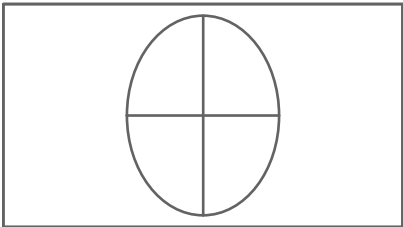

An anamorphic lens will stretch the image horizontally, restoring the original 2.35 ratio:

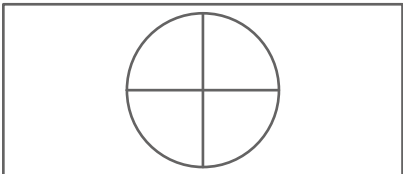

### Notes



*TheaterScope is used with an anamorphic lens.*



*If you use TheaterScope, set your screen aspect ratio to 16:9.*

## Digital Zoom

Digital zooming enlarges a section of the image, while the area outside the enlarged section is cropped out to preserve the overall image size.

- **Digital Zoom** defines the level of zoom that needs to be applied. If **Digital Zoom** is set to 0, then the other settings in the menu will be disabled.
- **Digital Pan** and **Digital Scan** specify the area that is being enlarged:
  - **Digital Pan** adjusts the horizontal coordinates.
  - **Digital Scan** adjusts the vertical coordinates.

The **Reset** command restores the default **Digital Zoom**, **Digital Pan** and **Digital Scan** values.

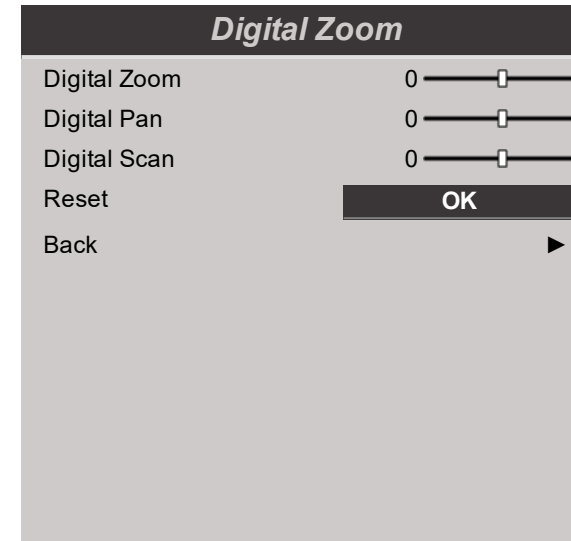

### Notes



*Digital Zoom is a temporary setting and not retained after an input change or power cycle.*

## Overscan

Use this setting to compensate for noisy or badly defined image edges.

**Crop** removes unwanted artifacts from the edges of your image by cropping the edges.

**Zoom** increases the size of the image to force the edges off-screen

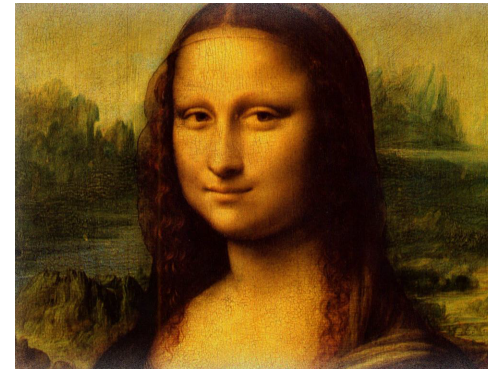
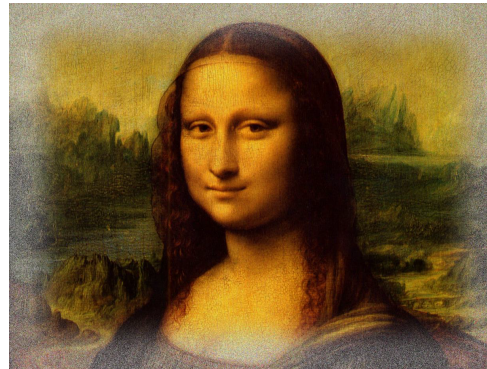
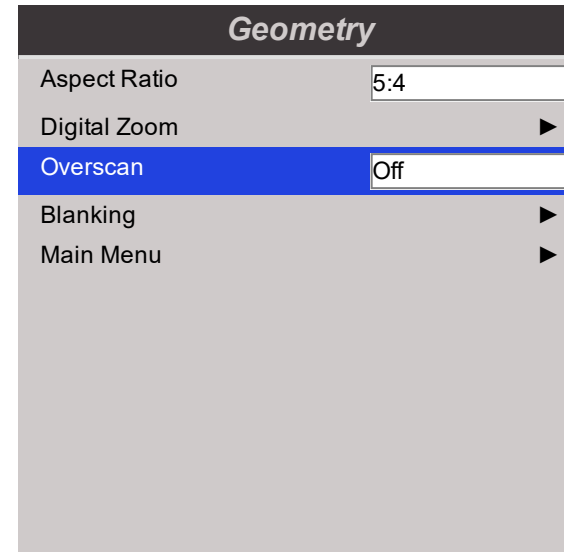

## Notes

## Blanking

Use this feature to:

- fit an odd-sized screen;
- cut off timecode dots in the top line of a picture;
- cut off subtitles, etc.

Select the edge you wish to blank and use the **LEFT** and **RIGHT** arrow buttons to determine the amount of correction.

Use the **Reset** command to restore blanked edges.

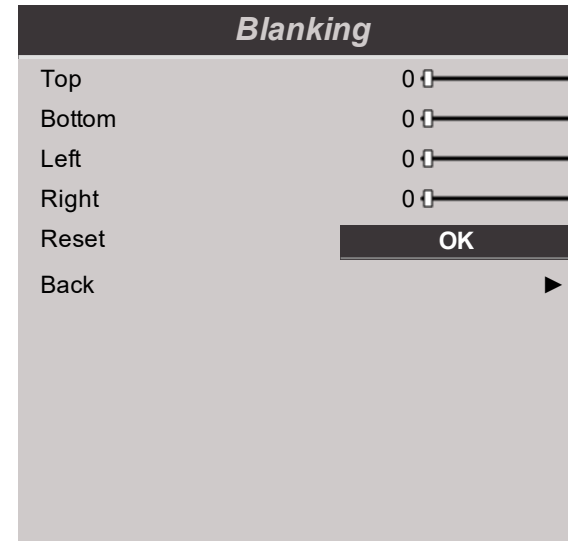

## Notes

# Setup

The screenshot shows a dark grey menu titled "Setup" with a list of options, each followed by a right-pointing arrow:

- System Setting
- Screen Setting
- Power Setting
- ColorMax Setting
- Control Setting
- OSD Settings
- Main Menu

## Notes

## System Setting

- **Orientation**  
Choose from **Front Tabletop**, **Front Ceiling**, **Rear Tabletop**, **Rear Ceiling** and **Auto-front**.
- **High Altitude**  
Choose from **Off**, **On** and **Auto**.
- **Clock Adjust**  
Access the submenu to set current date and local time.
- **Startup Logo**  
Choose from **Off**, **Original** and **User**.  
Select original to display the Digital Projection Ltd. logo on startup. Select User to display a custom logo. Use the custom logo upload tool to set the custom logo for the User option.
- **Blank Screen**  
Choose from **Logo**, **Black**, **Blue** and **White**.
- **PIC Mute**  
Access sub menu to set up the picture mute control.
- **Smear Reduction**  
Choose from **Off**, **6ms**, **7ms**, **8ms**, **9ms**, and **10ms**. When projecting footage with a high frame rate, fast moving images may appear as a smear across the display. Select a smear reduction value to reduce this effect.
- **Output Frame Rate**  
Choose from **Auto**, **48Hz**, **50Hz** and **60Hz**. Select Auto to use the same frame rate as the input signal. When switching between inputs on auto output frame rate, the projector measures the input frame rate before setting the output frame rate. When you know that all input frame rates are the same value, you can set an output frame rate to reduce the time it takes to switch between inputs.
- **HDMI Equalizer**  
Choose from **Auto**, **High**, **Middle** and **Low**. When transmitting signals via a HDMI cable, signal noise can disrupt the information received by the projector. High bandwidth signals, poor quality HDMI cables and longer HDMI cables can increase the signal noise. Use the HDMI Equaliser to improve HDMI signal acquisition.
- **Laser Color CAL**  
Select **OK** to recalibrate the colors.
- **Back**  
Go back to the previous menu.

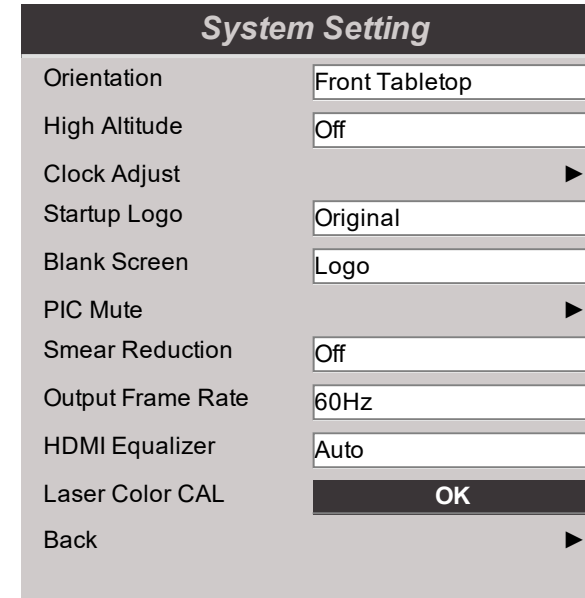

## Notes



*Smear reduction reduces the brightness of the displayed image*



*When using the Laser Color CAL, the command must be sent from head 1 in the system. Use the color max function to adjust the color settings of any additional heads.*

### Clock Adjust

Use this menu to set date (in **dd:MM:yyyy** format), time (in **HH:mm** format) and time zone.  
The date and time set here will affect any schedule created within the **Power On/Off** menu.

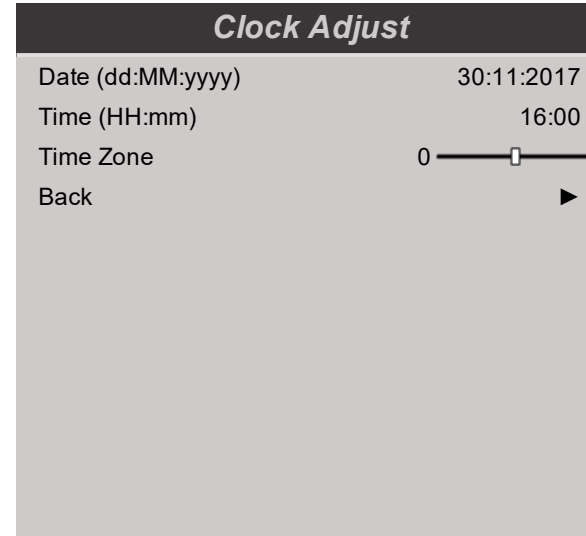

### PIC Mute

PIC mute allows the projected image to be hidden without turning the projector off.

- **PIC Mute**  
Choose from **Laser** and **DMD Blanking**. Select PIC Mute to turn the laser off when the PIC Mute activated. Select DMD Blanking to project a black image when PIC Mute is activated.

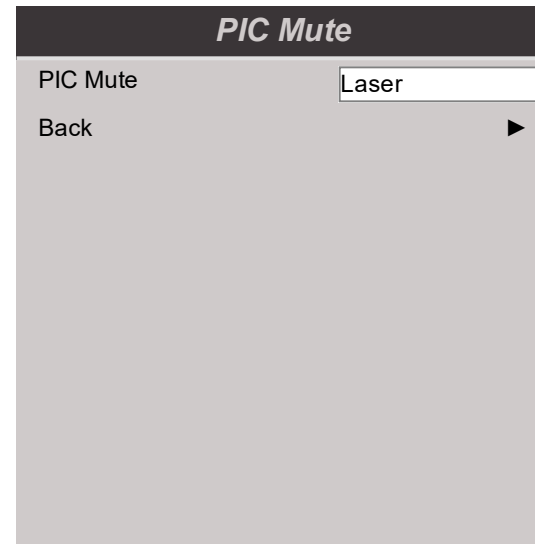

### Notes

## Screen Setting

- **Screen Format**  
Choose from **16:10**, **16:9**, **4:3** and **2.35:1**.
- **Screen Position**  
This setting is active when the screen format is not 16:10. Use the slider to adjust the position of the image within the unused space of the projectors display. The slider will adjust the position left or right when the screen format is 4:3, and up or down when the screen format is 16:9 or 2.35:1.
- **Back**  
Go back to the previous menu.

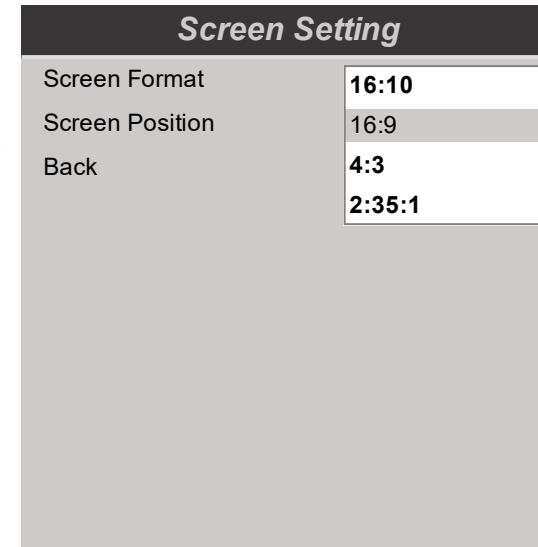

## Notes

See Aspect ratios explained on page 161 for information about how the image is modified when the aspect ratio of the input signal does not match the screen format.

## Power Setting

- **Auto Power On**  
Set this to **On** if you want the projector to start up immediately when the mains is connected. Set this to **Off** if you want the projector to go into STANDBY mode when the mains is connected. In this case, the projector will not start up until the **POWER** button is pressed on the control panel or the **ON** button is pressed on the remote control.
- **Auto Power Off**  
Choose from **Off**, **5 min**, **10 min**, **15 min**, **20 min**. Use this setting to activate STANDBY mode when no input source is detected after a period of time.
- **Schedule Management**  
Access sub menu to set up a power on-off schedule.
- **Instant Startup**  
When **ON** only the Laser will be turned off when the Power off command is given. A subsequent Power On will turn on the laser giving an apparent very fast power on.
- **Standby Period**  
Used with Instant Startup. If Instant Startup in **ON** and the projector is powered down then the projector will go to Standby after the selected "Standby Period" 30 minutes, 60 minutes, 90 minutes.

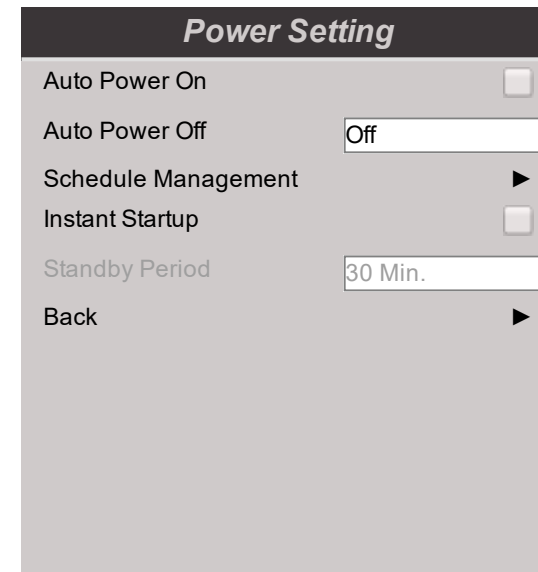

## Schedule Management

### • Scheduled on-off

Access this submenu to create a weekly schedule for automatic on and off times:

#### 1. Set the schedule:

- Use the **UP** and **DOWN** arrow buttons to highlight a row, then press **ENTER/OK** to enable edit mode.
- Within a row, navigate with the **LEFT** and **RIGHT** arrow buttons. Press **ENTER/OK** to select a day. Set time values with the **UP** and **DOWN** arrow buttons.
- To exit edit mode, press **ENTER/OK**. Alternatively, press **EXIT** if you don't want the changes to take effect. Move to another row using the **UP** and **DOWN** arrow buttons.

#### 2. To enable the schedule, set Schedule to **On**.

**Schedule Management**

Schedule	<input type="checkbox"/>						
On Day	<input type="checkbox"/>	<input type="checkbox"/>	<input type="checkbox"/>	<input type="checkbox"/>	<input type="checkbox"/>	<input type="checkbox"/>	<input type="checkbox"/>
	S	M	T	W	T	F	S
On Time							10:10
Off Day	<input type="checkbox"/>	<input type="checkbox"/>	<input type="checkbox"/>	<input type="checkbox"/>	<input type="checkbox"/>	<input type="checkbox"/>	<input type="checkbox"/>
	S	M	T	W	T	F	S
Off Time							10:10
On Day	<input type="checkbox"/>	<input type="checkbox"/>	<input type="checkbox"/>	<input type="checkbox"/>	<input type="checkbox"/>	<input type="checkbox"/>	<input type="checkbox"/>
	S	M	T	W	T	F	S
On Time							10:10
Off Day	<input type="checkbox"/>	<input type="checkbox"/>	<input type="checkbox"/>	<input type="checkbox"/>	<input type="checkbox"/>	<input type="checkbox"/>	<input type="checkbox"/>
	S	M	T	W	T	F	S
Off Time							10:10
Back							▶

## Notes

## ColorMax Setting

**Notes**

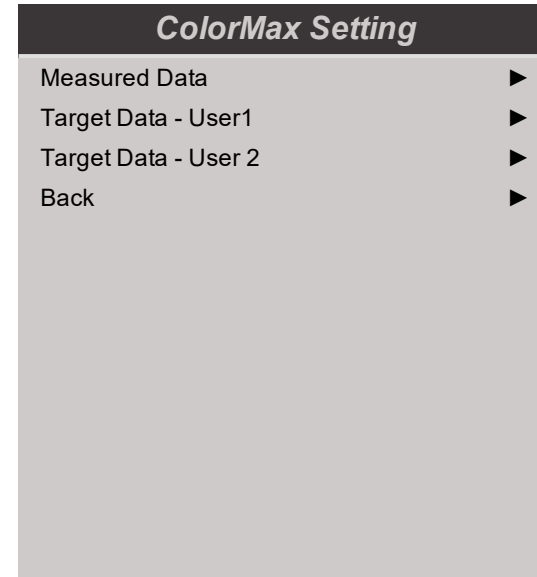

### Measured Data / Target Data

1. Use the **UP** and **DOWN** arrow buttons to highlight a color, then use the **LEFT** and **RIGHT** arrow buttons to navigate to the x or y coordinate.
2. Use the **UP** and **DOWN** arrow buttons to increase and decrease the value, respectively.
3. Exit edit mode:
  - press **ENTER/OK**, if you want to save the edited values.
  - press **EXIT**, if you do not wish to save the edited values
4. If necessary, highlight another color and repeat the procedure.

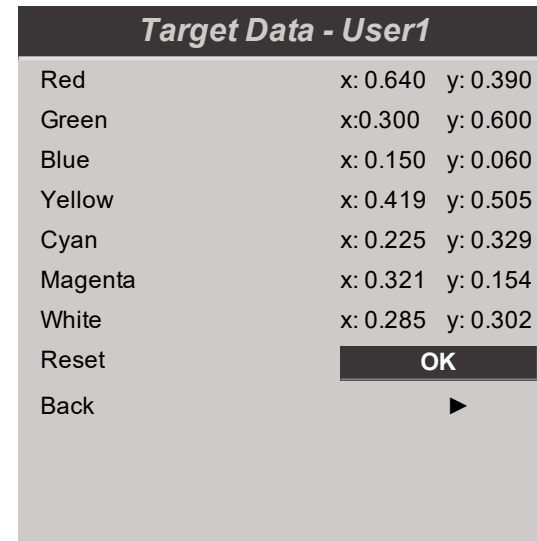
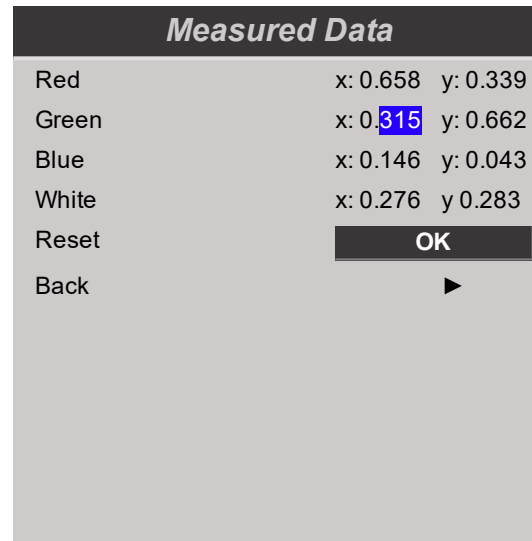

## Control Setting

- **Infrared Remote**

Set to **Off** if you wish to disable the remote control.

- **IR Code**

The projector and the remote control need a matching IR code: a two-digit number between **00** and **99**.

The default IR code is **00**. This is also a master code, which, if assigned to a remote, will work regardless of the value assigned to the projector.

- **To assign an IR code for the projector:** Select IR code. Use the slider to change the value.
- **To assign an IR code for the remote,** press and hold the **ADDR** button on the remote until the On indicator starts flashing. Release the **ADDR** button and while the indicator is still flashing, enter a two digit address using the numeric input buttons. The indicator will flash three times quickly to confirm the change.

- **IR Code Reset**

Use this command to unassign an IR code from the projector. This will revert the **IR Code** value to 00.

**To unassign an IR code from the remote control,** press and hold **ALT** and **ADDR** simultaneously until the On indicator flashes to confirm the change.

- **Hotkey Setting**

Access this submenu to set the option for each hotkey.

- **Keypad Button Backlight**

Choose from **On** or **Off**. Select On to switch the keypad backlight on. This will light the keypad controls on the projector.

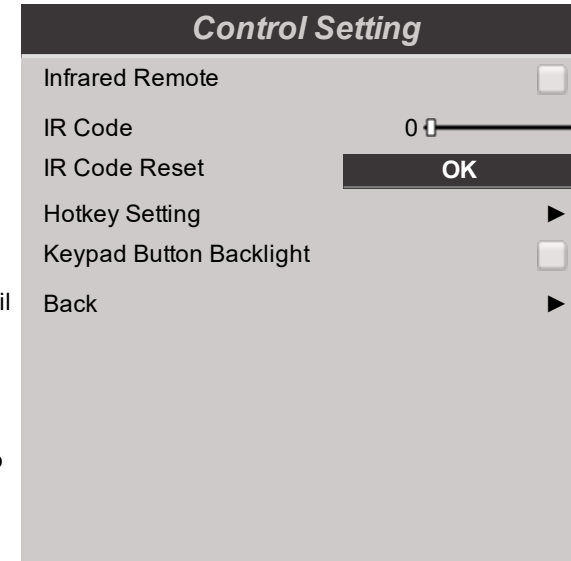

## Notes

## Hotkey Setting

- Hotkey1Function**  
 Choose from **Information**, **Test Pattern**, **Lens Memory Load**, **Ambient Brightness Correction** and **Freeze**. Select the function that you want to assign to hotkey1. This function will be activated when you press hotkey 1 on the control panel.
- Hotkey2Function**  
 Choose from **Information**, **Test Pattern**, **Lens Memory Load**, **Ambient Brightness Correction** and **Freeze**. Select the function that you want to assign to hotkey2. This function will be activated when you press hotkey 2 on the control panel.
- Hotkey3Function**  
 Choose from **Information**, **Test Pattern**, **Lens Memory Load**, **Ambient Brightness Correction** and **Freeze**. Select the function that you want to assign to hotkey3. This function will be activated when you press hotkey 3 on the control panel.

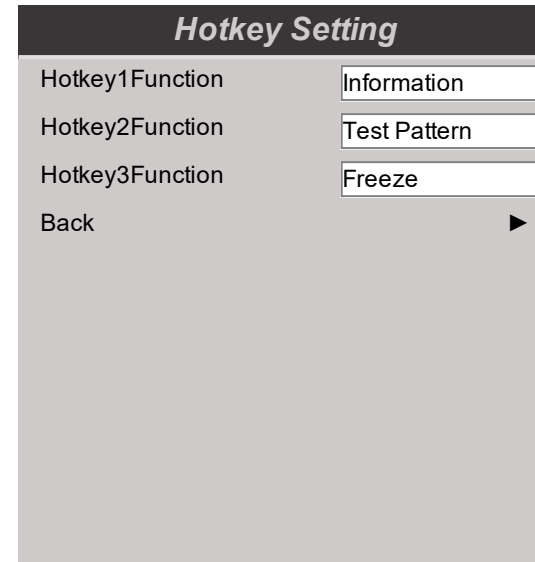

## OSD Settings

- Language**  
 Set the OSD language.
- Menu Position**  
 Set where the OSD should appear on the screen when activated. Choose from **Top Left**, **Top Right**, **Bottom Left**, **Bottom Right** and **Center**.
- Time Out**  
 Set how long the OSD should remain on screen if no buttons are pressed. Choose from **10 Seconds**, **20 Seconds** or **30 Seconds**. Choose **Always On** to disable this feature.
- Menu Rotation**  
 Choose from **Off**, **Clockwise** and **Anticlockwise**. Select a rotation option to rotate the OSD menu when the projector is displaying in portrait.
- Web Served OSD**  
 Access this submenu to set a PIN for the web served OSD.
- Memory**  
 Access this submenu to save up to four presets containing custom combinations of image settings, or to recall a saved preset.

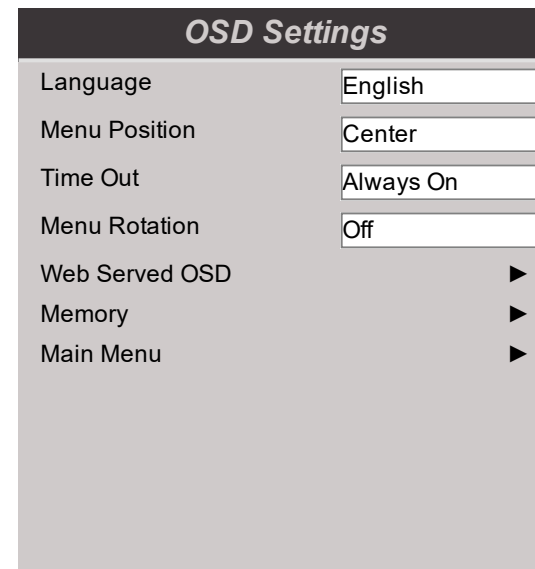

## Notes

## Web Served OSD

- **PIN Enabled**  
Enable to request the PIN number when you access the projector via the web served OSD.
- **PIN Number**  
Choose the PIN number for the projector.
- **PIN Reset**  
Select to reset the PIN number to the factory default (0000).
- **Back**  
Go back to the OSD menu.

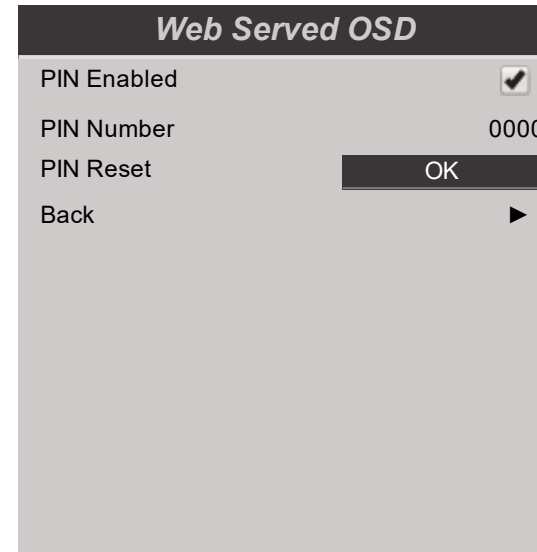

## Memory

The current image settings can be saved as a preset, which you can recall later. The default settings can be recalled at any time as well.

Up to four custom presets can be stored for each input.

The following settings are saved in a preset:

- From the **Image** menu — **Dynamic Black, Gamma, Brightness, Contrast, Saturation, Hue, Sharpness, Noise Reduction**
- From the **Color** menu — **Color Space, Color Mode, ColorMax, Color Temperature, Red Lift, Green Lift, Blue Lift, Red Gain, Green Gain, Blue Gain**
- From the **Geometry** menu — **Aspect Ratio, Overscan**

### To recall a saved preset:

- Select a recall memory preset from **Preset A to Preset D** and press **ENTER/OK**. Select **Default** to load factory default values.

### To save a preset:

- Select a save memory preset from **Preset A to Preset D** and press **ENTER/OK**.

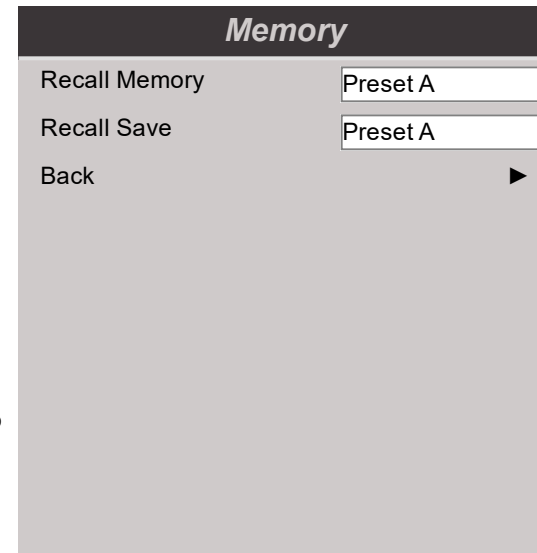

## Notes

 Presets from one input cannot be applied to another input.

 See Memory scheme and memory items on page 170 for information about the parameters that can be saved in a memory preset.

## Network

- **Network Setup**

Access this submenu to view the network settings for the projector

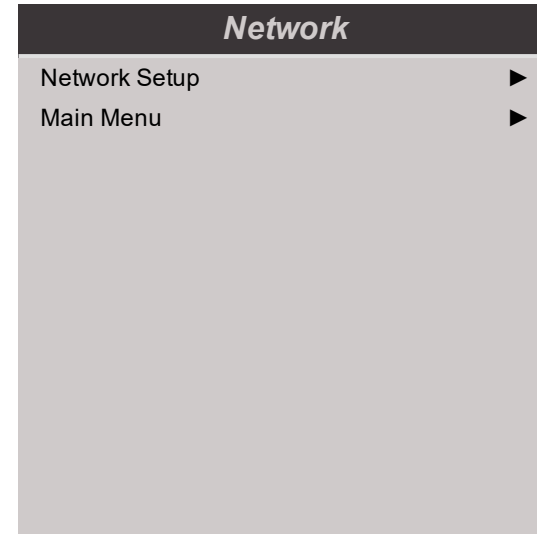

## Network Setup

- **IP, Subnet Mask, Gateway, MAC**

These settings are read-only. See Network on page 134 for guidance on network settings in the SCM.

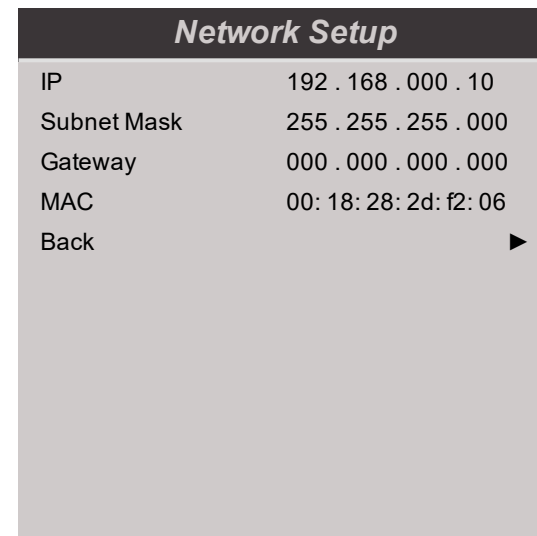

## Notes

## Information

This menu gives information about software and hardware configuration, input source and laser operating times. It also allows you to restore the factory default settings.

<i>Information</i>	
Model Name	Satellite Titan WU
Serial Number	X000XXXXX0000
Software Version 1	MD03-SE10-FE09
Software Version 2	STEP_D08-24-17-3120
Software Version 3	2.0.16.0-P503
OSD Version	2.0.16.0-P503
Active Source	HDMI 1
Signal Format	▶
System Status	▶
Thermal Status	▶
Factory Reset	<b>OK</b>
Main Menu	▶

## Signal Format

<i>Signal Format</i>	
Active Source	HDMI 1
Timing	3580x2160@59.9Hz
Scanning Frequency	H: 134.8 KHz V:59.9 Hz
Pixel Clock	593.80 MHz
Color Format	YCbCr 4:2:0 8 bit
HDR Format	No Data
Back	

## Notes

## System Status

<i>System Status</i>	
Atmospheric Pressure	98988 Pa (116m)
Altitude Mode	Auto
System Hours	1
Back	▶

## Thermal Status

<i>Thermal Status</i>	
Inlet Temp.	Ti1 = 24 (C)
DMD Temp.	38 (C)
Fan 1-3 Speed	1399 / 1402 / 4391
Fan 4-6 Speed	1310 / 1200 / 1205
Fan 7-10 Speed	1211 / 1407 / 1410
Water Pump Speed	3506
Back	▶

## Notes

## Factory Reset

To restore the factory default settings:

1. Navigate to **Factory Reset** and press **ENTER/OK**.
2. When prompted, press **OK** to confirm your choice, or press **Cancel** to cancel.

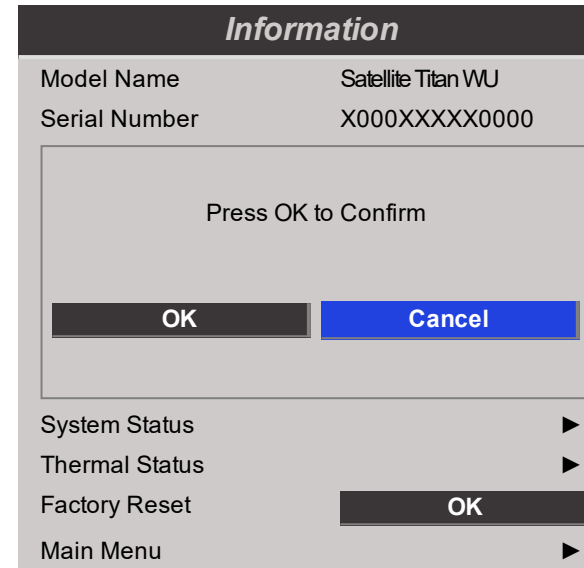

### Notes



*Factory reset does not reset the Network settings, or High Altitude mode*

This page is intentionally left blank



# *Satellite Titan WUXGA 120Hz*

Digital Video Projector

MLS 10000 TOUCHSCREEN OPERATING GUIDE



A brand of  DELTA

## Introduction to the MLS 10000 Touchscreen

This section describes the operation of the Satellite Modular Laser Source (MLS 10000). Please refer to the page 15 for guidance on installing the MLS 10000 as part of the Satellite system. Your MLS 10000 has the following key features:

- RGB Laser light source
- Generates 10,000 Lumens per MLS
- Can be paralleled up with other modules for increased light output with the appropriate SLC
- Can be linked to up to 4 paralleled Satellite Heads for multiple displays with the appropriate SLC

The MLS displays a touch screen menu when the power is on.

### Using the menus

The MLS displays a touch screen menu when the power is on.

Some menus have items that are hidden by the bottom of the screen. Press and drag to scroll the menu up and down.

When you open a menu, the page consists of the following elements:

- Title bar at the top shows which menu you have accessed. Additional buttons are available in the title bar:
  - tap the refresh button to refresh the information on the screen
  - tap the home button to return to the main menu
- Available and unavailable items Unavailable items appear a pale gray color. Whether an item is available may depend on other settings.
- The text or symbol to the right of an item shows whether the item:
  - has information only
  - has a value that can be selected. The current selection is displayed in a box. Tap to select a new option
  - has a tick box. A tick indicates that the feature is enabled. Tap to enable or disable the feature
  - has a slider. A box displays the current value of the setting. Press and drag the slider to adjust the value
  - opens a sub-menu. Tap the arrow button to open the sub menu
  - executes a command. Tap the command button to execute.

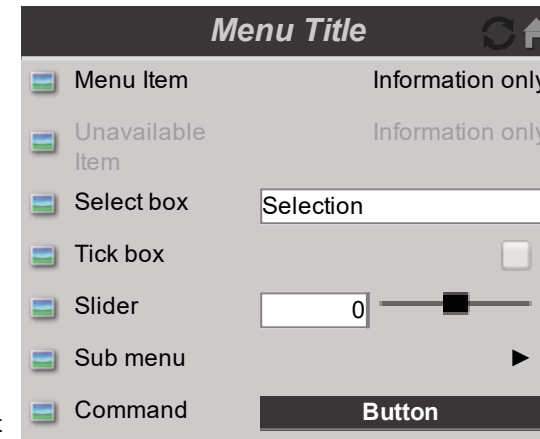

*Inside a Menu*

### Notes

## Main Menu

- **Laser, Setup, Information, Help.**  
Tap to open these menus and access various settings.

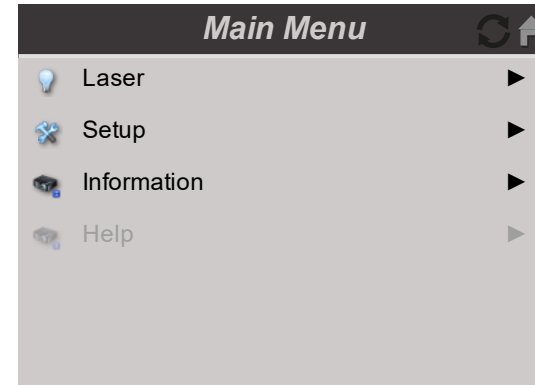

*Touchscreen Display: Top Level Menu*

## Laser

- **Power Mode**
  - **Eco** will automatically set the laser power to 80%.
  - **Normal** will set the power to 100%.
  - Set to **Custom** if you wish to adjust the power manually.
- **Power Level**  
This setting is only available if **Power Mode** is set to **Custom**.  
Choose a value between 20 and 100, ranging from 20% to 100% laser power.
- **Constant Brightness**  
Once the **Power Mode** has been set to **Custom**, then Constant Brightness can be turned **ON**.  
The Constant Brightness setting will maintain the projectors set brightness until the maximum laser power has been reached (this maximum laser power will decrease overtime). Hence, the lower the set Constant Brightness power level the longer the set brightness output will be maintained.
- **Main Menu**  
Tap to go back to the main menu.

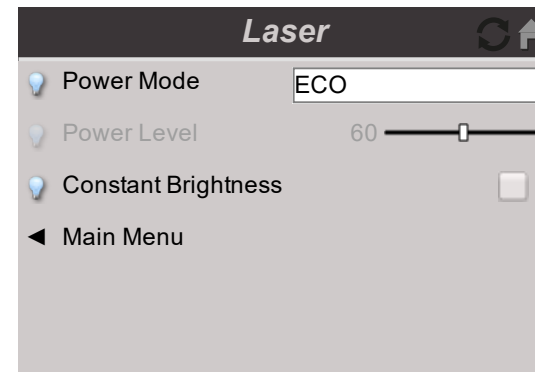

## Notes

## Setup

- **OSD Settings**  
Press **ENTER/OK** to open the submenu.
- **Main Menu**  
Go back to the main menu.

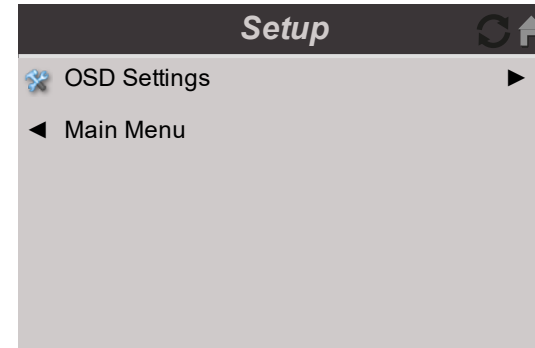

## OSD Settings

- **Language** sets the OSD language.
- **Back**  
Tap to go back to the setup menu.

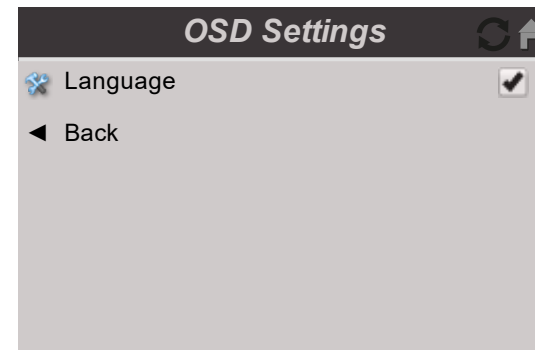

## Network

- **IP, Subnet Mask, Gateway, MAC**  
These settings are read-only. See Network on page 134 for guidance on network settings in the SCM.
- **Main Menu**  
Tap to go back to the main menu.

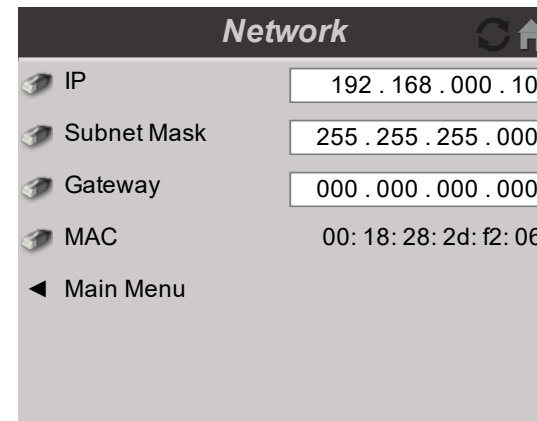

## Notes

## Information

This menu gives information about software and hardware configuration, input source and laser operating times. It also allows you to restore the factory default settings.

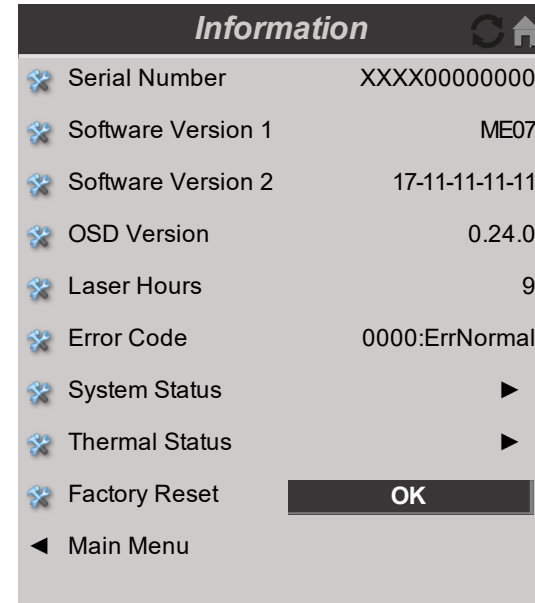

## System Status

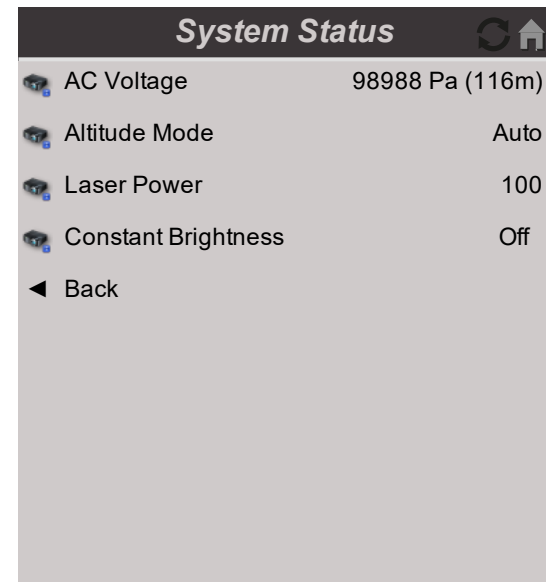

## Notes

## Thermal Status

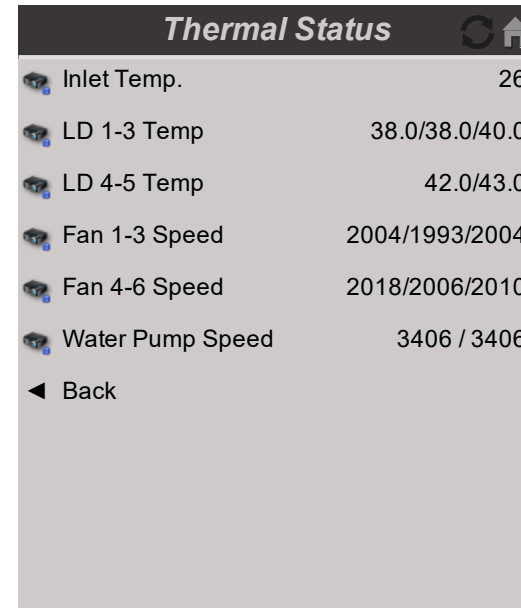

## Factory Reset

To restore the factory default settings:

1. Navigate to **Factory Reset** and press **ENTER/OK**.
2. When prompted, press **OK** to confirm your choice, or press **Cancel** to cancel.

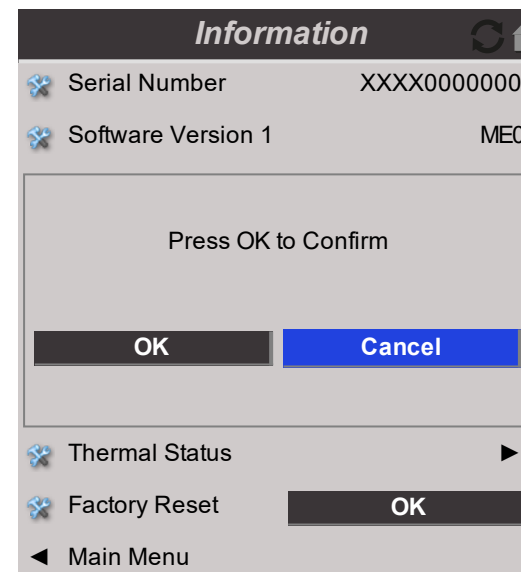

 *Factory reset does not reset the Network settings, or High Altitude mode*

# *Satellite Titan WUXGA 120Hz*

Digital Video Projector

MLS 20000 / MLS 30000 LCM SCREEN OPERATING GUIDE



A brand of  **DELTA**

## Introduction to the MLS 20000 / MLS 30000 LCM Screen

This section describes the operation of the Satellite Modular Laser Source (MLS 20000 / MLS 30000). Please refer to the page 15 for guidance on installing the MLS as part of the Satellite system. Your MLS has the following key features:

- RGB Laser light source
- Generates 20,000 Lumens per MLS 20000
- Generates 30,000 Lumens per MLS 30000
- Can be paralleled up with other modules for increased light output with the appropriate SLC
- Can be linked to up to 4 paralleled Satellite Heads for multiple displays with the appropriate SLC

The MLS displays a LCM screen menu when the power is on.

### LCM Pages

The information on the LCM is displayed in multiple pages.

- Press and hold the **Info Key** for more than 1 second to show the next page. **1**  
The pages are displayed in the following order:
  1. System Status (default)
  2. System Information
  3. Network Information
  4. Thermal Information
  5. Error Page

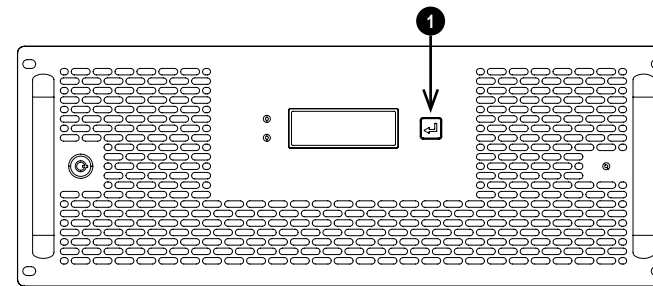

### System Status

Information only:

- Model Name
- Status

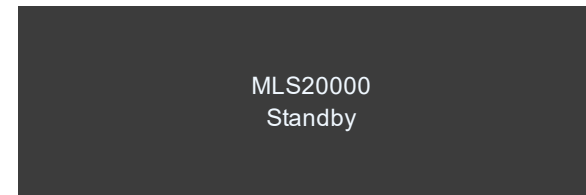

### Notes

*The LCM is view only information. The features of the MLS are controlled via served web pages. The served web pages can be accessed via the SCM touchscreen or a connected device. See Introduction to the SCM Touchscreen on page 132 for guidance on the SCM touchscreen. See Served web pages on page 173 for guidance on using the served web pages.*

*The controls in the served web pages for the MLS 20000 / MLS 30000 are the same as the controls for the MLS 10000. See Introduction to the MLS 10000 Touchscreen on page 122.*

## System Information

Information only:

- Model Name
- Serial Number
- FW Version
- Laser Status (Power)

```
Model: MLS20000
SN: xxxxxxxxxxxx
MCU-IF-LD-PI
Light Off
```

## Network Information

Information only:

- IP Address
- SubnetMask
- GateWay
- MAC

```
IP:192.168.253.125
Mask:255.255.255.0
GWay:192:168:253:241
MAC:D8:27:eb:2a:e2:e3
```

## Thermal Information

Information only:

- Temperature: LD B
- Temperature: LD G / LD R
- Laser Hours
- AC Voltage

```
Inlet Temp LD B: 0°C
G: 0°C R: 0°C
Laser Hours: xxxxx
Voltage: N/A
```

## Error Page

Information only:

- Model Name
- Error Code
- Description

```
MLS20000
ERROR CODE:0x0000
NORMAL
```

**Notes**

This page is intentionally left blank

## SCM TOUCHSCREEN OPERATING GUIDE



## Introduction to the SCM Touchscreen

This section describes the operation of the Satellite Control Module (SCM) touchscreen control panel. Please refer to the page 15 for guidance on installing the SCM as part of the Satellite system. Your SCM has the following key features:

- Centralized system configuration management and control
- User remote control via LAN.
- System operation monitoring, including Interlocks and warnings.

The SCM displays a touchscreen menu when the power is on.

**Notes**

## Using the menus

The SCM displays a touch screen menu when the power is on.

### System Configuration

- **System Controller.**  
Tap to open this menu and access various settings.
- **Component.**  
A component sub menu provides information about another module installed in the system. This could be a Satellite Head or an MLS. The components shown will match the components installed in your system. This could be 1-3 MLS and 1 Satellite Head or 1 MLS and 1-4 Satellite Heads. There are two levels of access:
  - **Information Only**  
Tap a component to open a submenu that shows view only information about the module.
  - **Served Web Page**  
This allows you to adjust the settings of the module.  
Tap and hold the menu icon in the header to enable a link to the served web page for the modules. The component names will turn green. Tap a component menu to access its touchscreen menus. A message is displayed to indicate that the SCM is connecting to the module. The served web pages for the module are displayed when the connection is established.

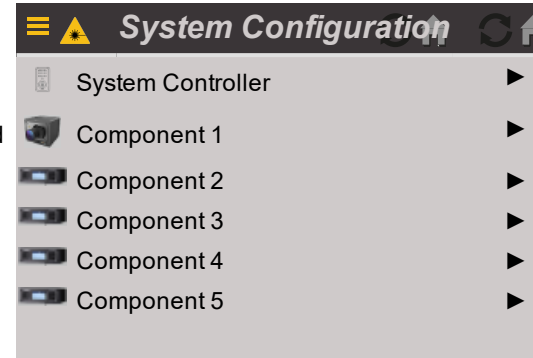

*On Screen Display (OSD): Top Level Menu*

### Main Menu

- **Laser Power, Interlocks, Network, Information.**  
Tap to open these menus and access various settings.
- **Help.**  
Use a QR code scanner to open a webpage containing the manual documentation for this system.

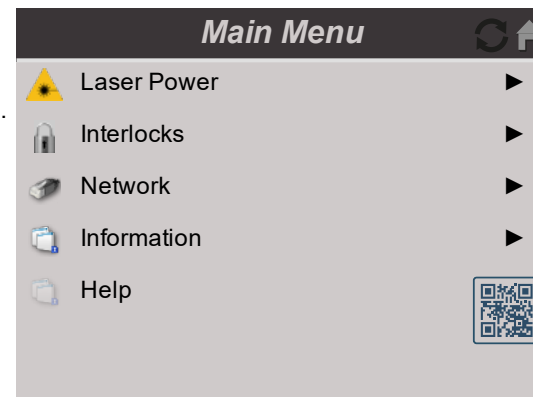

*On Screen Display (OSD): Top Level Menu*

### Notes

## Laser Power

- **Laser ON.**  
Tap to turn the laser on. A message is displayed to indicate that the system interlocks are engaging. The laser will switch on when the interlocks are engaged.
- **Laser OFF.**  
Tap to turn the laser off.

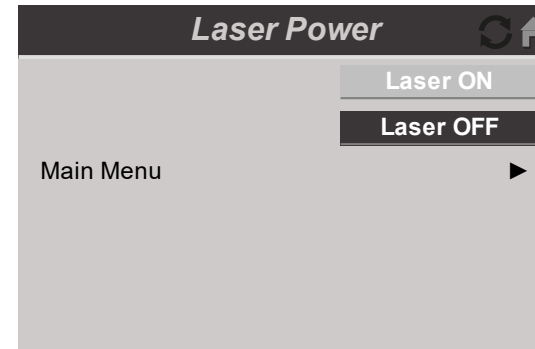

## Interlocks

Displays the current state of interlocks in the Satellite system:

- A green tick indicates that the interlock is currently closed and the system can operate as normal.
- A red error symbol indicates that the interlock has been opened.

Every interlock must be closed to allow the system to operate as normal.

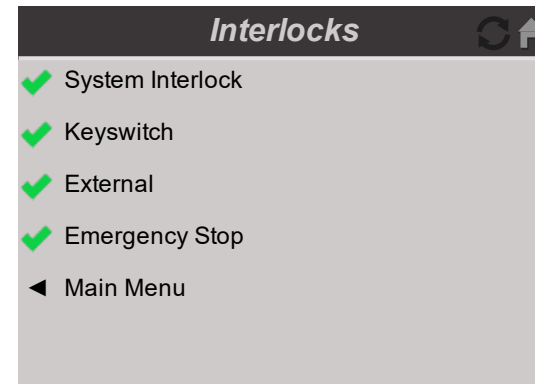

See *Interlock Switches* on page 26 for more information about system interlocks.

## Network

- **DHCP, Network Address, Subnet Mask**  
Tick **DHCP** to assign the IP address via a DHCP server.  
If **DHCP** is not enabled, edit the Network address and Subnet Mask as required.
- **Main Menu**  
Go back to the main menu.

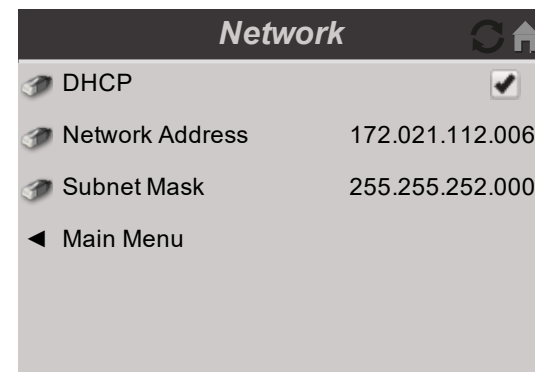

## Notes

## Information

Each submenu in this menu provides information about this system.

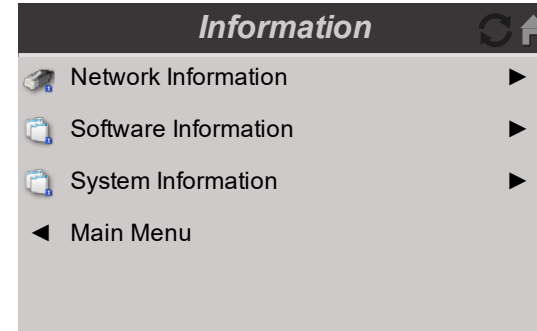

## Network Information

Information Only

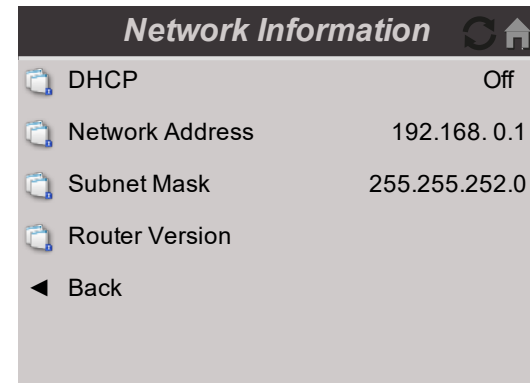

## Software Information

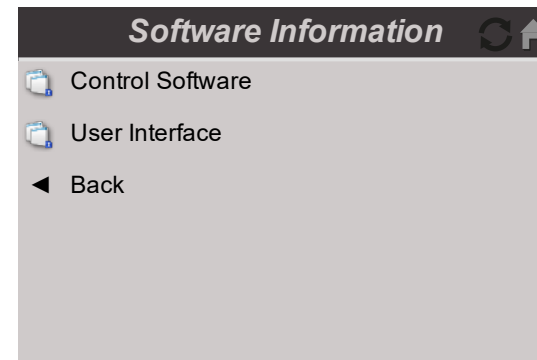

Information Only







**Notes**

## System Information



Information Only





**System Information**  

 Model	Satellite Control Module
 Name	SCM0004
 Serial Number	0004
 Hardware Information	▶
 Service Information	▶
◀ Back	

## Hardware Information

Information Only

**Hardware Information**  

 Board Type	9
 Edition	A
 Artwork	A
 Mod State	5
◀ Back	

**Notes**

### Service Information

Information Only

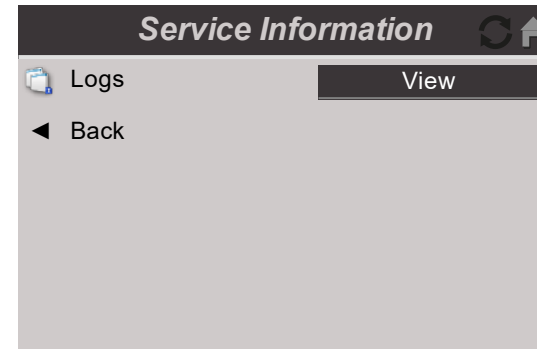

### Component menu

Information Only

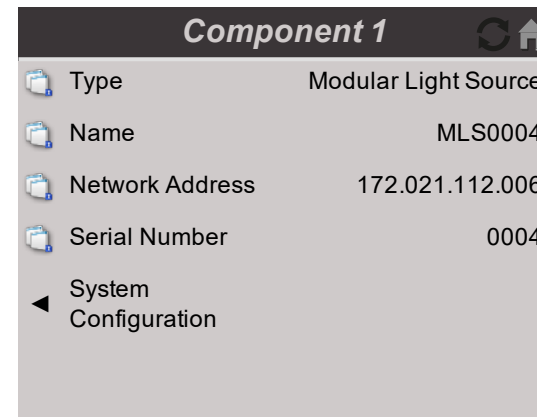

**Example Component**

### Notes

This page is intentionally left blank

# *Satellite Titan WUXGA 120Hz*

Digital Video Projector

REFERENCE GUIDE



A brand of  **DELTA**

# Appendix A: Product labels

## Satellite Head

### Notes

**DIGITAL PROJECTION**

Name of Product: DLP Projector  
Nom du produit: DLP Projecteur  
产品名称/產品名稱: 数字投影机 / 數位投影机

Model / Modèle: Satellite Titan Head WU  
型号/型號

Part No. / Numéro de pièce: 120-889A  
零件号/零件號

Serial No. / Numéro de série: Code 39 or 128 for Serial No.  
序号/序號: "YYYYYYYYXXXX"

Power / Puissance: 100-240V ~ 50/60Hz 3.7A  
电压/電源

警告: 此为A级产品, 在生活环境中, 该产品可能会造成无线干扰, 在这种情况下, 可能需要用户对干扰采取切实可行的措施。  
警告使用者: 这是甲类的资讯产品, 在居住的环境中使用时, 可能会造成烦扰干扰, 在这种情况下, 使用者应采取某些措施以减低干扰。

**WARNING** Isolate mains before removing cover.  
**ATTENTION** Isoler les conduites avant d'enlever le couvercle.  
注意/注意 打开前先切断主电源/打開前先切斷主電源

To reduce the risk of fire or electric shock, do not expose this equipment to rain or moisture.  
Pour réduire le risque d'incendie ou d'électrocution, n'exposez pas cet équipement à la pluie ou à l'humidité.  
请勿将投影机置于雨中或潮湿环境中以降低起火或触电风险。  
請勿將投影机放在雨中或潮濕環境中以降低起火或電擊的風險。

This device complies with Part 15 of the FCC Rules. Operation is subject to the following two conditions: (1) This device may not cause harmful interference. (2) This device must accept any interference received, including interference that may cause undesired operation. CAN ICES-003(A) / NMB-003(A)

Delta Electronics (Jiangsu) Ltd.  
No. 1688, Jiangning East Rd.  
Wujiang Economic and Technological Development Zone,  
Suzhou City, Jiangsu Province, P.R.C.215200

US LISTED  
Digital Projection Limited  
英國薩往有限公司 / 英國薩往有限公司  
Greenside Way, Middleton Manchester, UK, M24 1XX  
英國曼爾斯哥特 格林賽得路 / 英國曼爾斯哥特 格林賽得路

Follow link for Projector Documentation  
Suivez le lien pour accéder à la documentation du projecteur  
Product documentation finden Sie unter dem Link.  
この二次元バーコードをスキャンしてプロジェクターのデータを取得してください  
请扫描条码来取得投影机的文件  
프로젝터 설명서를 보려면 링크를 클릭하십시오

M.F DATE: YYYYMM.DD  
Made in China  
Fabriqué en Chine  
中國製造 / 中國製造

Manufacturers ID Label

3262355700

**LASER APERTURE**  
避免受到從本窗口射出的激光輻射的照射

**LASER ENERGY : EXPOSURE NEAR APERTURE MAY CAUSE BURNS**

Laser Aperture Label

**WARNING**  
DO NOT LOOK INTO LENS  
注意: 高亮, 请勿注视镜头  
注意: 高亮, 請勿注視鏡頭

3262187600

Laser Warning Label

CLASS 1 / RG3 Laser Product  
Warning! Do not look Into the beam.  
No direct exposure to beam Is Permitted.  
CLASS 1 BS EN IEC 60825-1:2014  
RG3 BS EN IEC 62471-5:2015  
Hazard Distance : Refer to Manual  
Not for Household Use  
CLASSE 1 / RG3 Laser Produit  
Attention! Ne pas regarder dans le faisceau.  
Pas d'exposition directe faisceau est autorisée.  
CLASS 1 BS EN IEC 60825-1:2014  
RG3 BS EN IEC 62471-5:2015  
Distance de danger : Se reporter au manuel  
Pas à usage domestique

Light Hazard Explanatory Label

**WARNING**  
**ISOLATE MAINS BEFORE REMOVING COVER**  
注意 打开前先切断主电源  
注意 打開前先切斷主電源

3262187600

Electrical Safety Label



*Fibre Interface Label*



*Laser On Hazard Indicator Label*

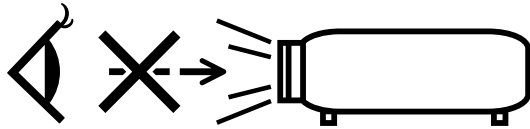

*Laser Hazard Label*



*Lens Obstruction Hazard Label*

DO NOT let a laser beam directly enter the projector lens.



*Lens Safety Label*

This product is in conformity with performance standards for laser products under 21 CFR 1040, except with respect to those characteristics authorized by Variance Number 2021-V-0192 effective on March 20, 2021. 3262355800

*FDA Laser Standards Conformity Label*

**Notes**

**Label Locations**

1. Location of the Laser On Hazard Indicator Label on the front of the Satellite Head.
2. Location of the Laser Warning Label on the front of the Satellite Head.
3. Location of the Fiber Interface Label on the rear of the Satellite Head.

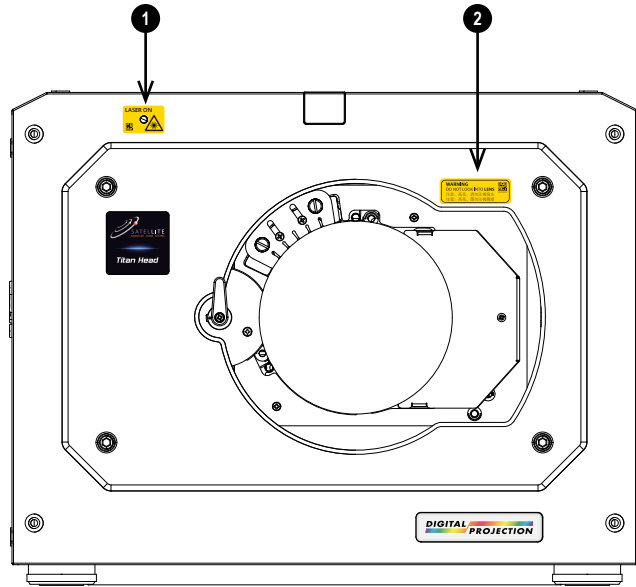

**Satellite Head Front**

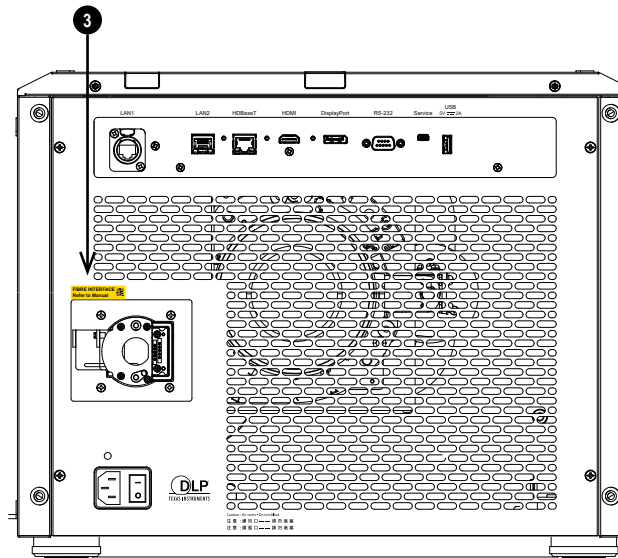

**Satellite Head Rear**

4. Location of the Manufacturer's ID Label on the left side of the Satellite Head.
5. Location of the Light Hazard Explanatory Label and the FDA Standards Conformity Label on the left side of the Satellite Head.

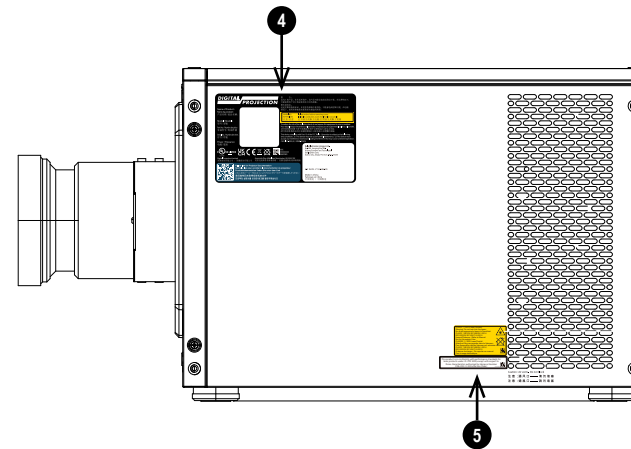

**Satellite Head Left Side**

**Notes**

6. Location of the Electrical Safety Labels on the top of the Satellite Head.
7. Location of the Lens Safety Label on the top of the Satellite Head.
8. Location of the Laser Hazard Label on the top of the Satellite Head.
9. Location of the Laser Aperture Label on the top of the Satellite Head.
10. Location of the Lens Obstruction Hazard Label on the top of the Satellite Head.

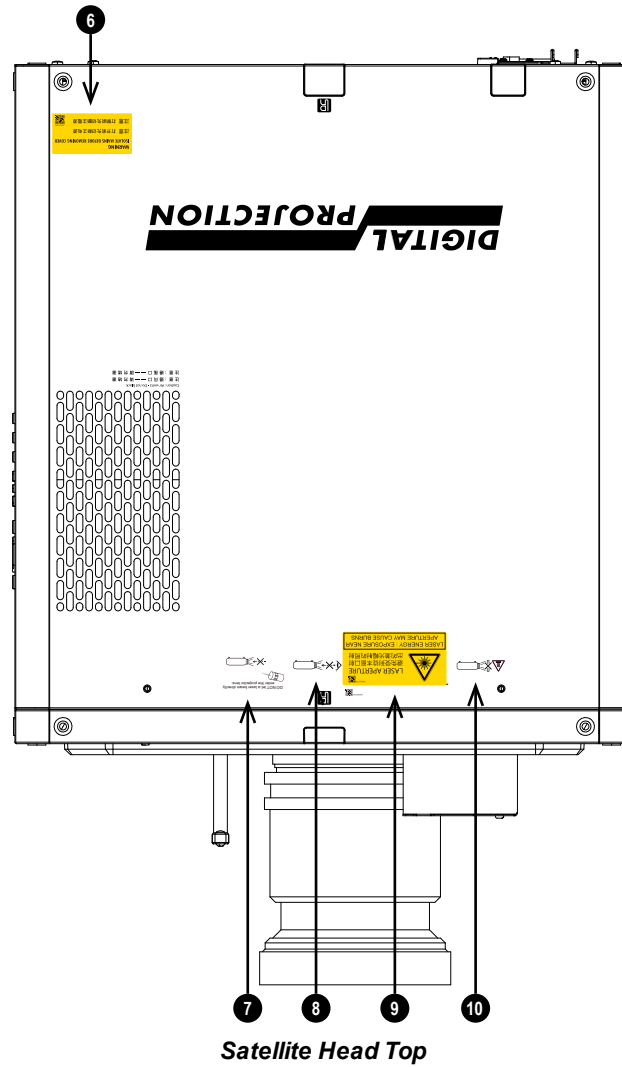

### Notes

# Modular Light Source

## Notes

**Name of Product:** Laser Light Module  
**Nom du produit:** Module De Lumière Laser  
**产品名称/产品名稱:** 激光光源模块 / 雷射光源模組

**Model / Modèle:** MLS 10000  
**型号/型號:** 122-004X

**Part No. / Numéro de pièce:** 122-004X  
**零件号/零件號:** "WYWWXXXXXX"

**Serial No. / Numéro de série:** Code 39 for 128 for Serial No.  
**序号/序號:** "WYWWXXXXXX"

**Power / Puissance:** 100-240V ~ 50/60Hz 10.1-4.9A  
**电源/電源:**

**US LISTED**

Digital Projection Limited  
 英國輝佳有限公司 / 英國輝佳有限公司  
 Greenide Way, Middleton Manchester, UK, M24 1XX  
 英國曼徹斯特格林賽得路 / 英國曼徹斯特格林賽得路

**Follow link for Projector Documentation**  
 Suivre le lien pour accéder à la documentation du projecteur  
 Produktdokumentation finden Sie unter dem Link  
 この二次元バーコードをスキャンしてプロジェクターのデータを取得してください  
 请扫描条码取得投影机文件  
 此二维码扫描时请扫描投影机文件

**WARNING** Isolate mains before removing cover.  
**ATTENTION** Isoler les conduites avant d'enlever le couvercle.  
**注意/注意** 打开前先切断主电源/打開前先切斷主電源

To reduce the risk of fire or electric shock, do not expose this equipment to rain or moisture.  
 Pour réduire le risque d'incendie ou d'électrocution, n'exposez pas cet équipement à la pluie ou à l'humidité.  
 請勿將投影机置于雨中或潮濕環境中以降低起火或電擊風險。  
 請勿將投影机放在雨中或潮濕環境中以降低起火或電擊的風險。

This device complies with Part 15 of the FCC Rules. Operation is subject to the following two conditions: (1) This device may not cause harmful interference. (2) This device must accept any interference received, including interference that may cause undesired operation. CAN ICES-003(A)/NMB-003(A)

**Delta Electronics (Jiangsu) Ltd.**  
 No.1688, Jiangong East Rd.,  
 Wujiang Economic and Technological  
 Development Zone,  
 Suzhou City, Jiangsu Province, P.R.C.215200

M.F DATE: YYYY.MM.DD

Made in China  
 Fabriqué en Chine  
 中國製造 / 中國製造

Manufacturers ID Label - MLS 10000

**Name of Product:** Laser Light Module  
**Nom du produit:** Module De Lumière Laser  
**产品名称/产品名稱:** 激光光源模块 / 雷射光源模組

**Model / Modèle:** MLS 20000  
**型号/型號:** 123-445A

**Part No. / Numéro de pièce:** 123-445A  
**零件号/零件號:** "WYWWDHWCYSSSS"

**Serial No. / Numéro de série:** Code 39 for 128 for Serial No.  
**序号/序號:** "WYWWDHWCYSSSS"

**Power / Puissance:** 100-240V ~ 50/60Hz 5.5-10.5A  
**电源/電源:**

**US LISTED**

Digital Projection Limited  
 英國輝佳有限公司 / 英國輝佳有限公司  
 Greenide Way, Middleton Manchester, UK, M24 1XX  
 英國曼徹斯特格林賽得路 / 英國曼徹斯特格林賽得路

**Follow link for Projector Documentation**  
 Suivre le lien pour accéder à la documentation du projecteur  
 Produktdokumentation finden Sie unter dem Link  
 この二次元バーコードをスキャンしてプロジェクターのデータを取得してください  
 请扫描条码取得投影机文件  
 此二维码扫描时请扫描投影机文件

**WARNING** Isolate mains before removing cover.  
**ATTENTION** Isoler les conduites avant d'enlever le couvercle.  
**注意/注意** 打开前先切断主电源/打開前先切斷主電源

To reduce the risk of fire or electric shock, do not expose this equipment to rain or moisture.  
 Pour réduire le risque d'incendie ou d'électrocution, n'exposez pas cet équipement à la pluie ou à l'humidité.  
 請勿將投影机置于雨中或潮濕環境中以降低起火或電擊風險。  
 請勿將投影机放在雨中或潮濕環境中以降低起火或電擊的風險。

This device complies with Part 15 of the FCC Rules. Operation is subject to the following two conditions: (1) This device may not cause harmful interference. (2) This device must accept any interference received, including interference that may cause undesired operation. CAN ICES-003(A)/NMB-003(A)

**Delta Electronics (Jiangsu) Ltd.**  
 No.1688, Jiangong East Rd.,  
 Wujiang Economic and Technological  
 Development Zone,  
 Suzhou City, Jiangsu Province, P.R.C.215200

M.F DATE: YYYY.MM.DD

Made in China  
 Fabriqué en Chine  
 中國製造 / 中國製造

Manufacturers ID Label - MLS 20000

**Name of Product:** Laser Light Module  
**Nom du produit:** Module De Lumière Laser  
**产品名称/产品名稱:** 激光光源模块 / 雷射光源模組

**Model / Modèle:** MLS 30000  
**型号/型號:** 123-799A

**Part No. / Numéro de pièce:** 123-799A  
**零件号/零件號:** "WYWWDIRCYSSSS"

**Serial No. / Numéro de série:** Code 39 for 128 for Serial No.  
**序号/序號:** "WYWWDIRCYSSSS"

**Power / Puissance:** 100-240V ~ 50/60Hz 6.5-14.5A  
**电源/電源:**

**US LISTED**

Digital Projection Limited  
 英國輝佳有限公司 / 英國輝佳有限公司  
 Greenide Way, Middleton Manchester, UK, M24 1XX  
 英國曼徹斯特格林賽得路 / 英國曼徹斯特格林賽得路

**Follow link for Projector Documentation**  
 Suivre le lien pour accéder à la documentation du projecteur  
 Produktdokumentation finden Sie unter dem Link  
 この二次元バーコードをスキャンしてプロジェクターのデータを取得してください  
 请扫描条码取得投影机文件  
 此二维码扫描时请扫描投影机文件

**WARNING** Isolate mains before removing cover.  
**ATTENTION** Isoler les conduites avant d'enlever le couvercle.  
**注意/注意** 打开前先切断主电源/打開前先切斷主電源

To reduce the risk of fire or electric shock, do not expose this equipment to rain or moisture.  
 Pour réduire le risque d'incendie ou d'électrocution, n'exposez pas cet équipement à la pluie ou à l'humidité.  
 請勿將投影机置于雨中或潮濕環境中以降低起火或電擊風險。  
 請勿將投影机放在雨中或潮濕環境中以降低起火或電擊的風險。

This device complies with Part 15 of the FCC Rules. Operation is subject to the following two conditions: (1) This device may not cause harmful interference. (2) This device must accept any interference received, including interference that may cause undesired operation. CAN ICES-003(A)/NMB-003(A)

**Delta Electronics (Jiangsu) Ltd.**  
 No.1688, Jiangong East Rd.,  
 Wujiang Economic and Technological  
 Development Zone,  
 Suzhou City, Jiangsu Province, P.R.C.215200

M.F DATE: YYYY.MM.DD

Made in China  
 Fabriqué en Chine  
 中國製造 / 中國製造

Manufacturers ID Label - MLS 30000

**CLASS 1 / RG3 Laser Product**  
**Warning! Do not look into the beam.**  
 No direct exposure to beam is permitted.  
 CLASS 1 BS EN IEC 60825-1:2014  
 RG3 BS EN IEC 62471-5:2015  
 Hazard Distance : Refer to Manual  
 Not for Household Use  
 CLASSE 1 / RG3 Laser Produit  
 Attention! Ne pas regarder dans le faisceau.  
 Pas d'exposition directe faisceau est autorisée.  
 CLASS 1 BS EN IEC 60825-1:2014  
 RG3 BS EN IEC 62471-5:2015  
 Distance de danger : Se reporter au manuel  
 Pas à usage domestique

Light Hazard Explanatory Label



**Laser Warning Label**



**Compressor Transportation Warning Label**



**Fibre Interface Label**



**Laser On Hazard Indicator Label**

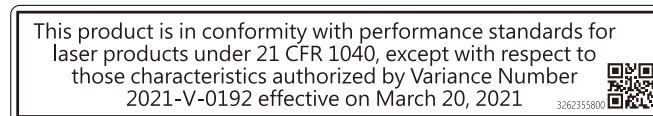

**FDA Laser Standards Conformity Label**

## Notes

### MLS 10000 Label Locations

1. Location of the Laser On Hazard Indicator Label on the front of the MLS.
2. Location of the Fiber Interface Label on the rear of the MLS.
3. Location of the FDA Standards Conformity Label on the rear of the MLS.
4. Location of the Light Hazard Explanatory Label on the rear of the MLS.
5. Location of the Manufacturer's ID Label on the left side of the MLS.
6. Location of the Internal Laser Warning Label inside the top cover of the MLS.

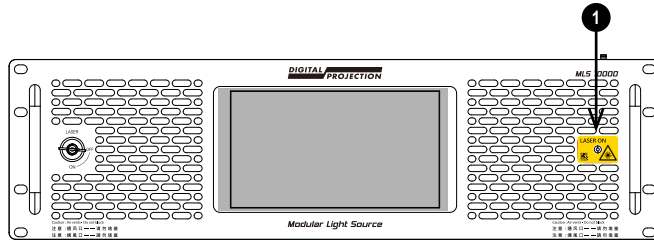

**MLS Front**

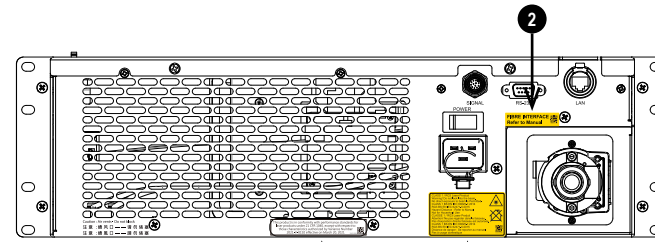

**MLS Rear**

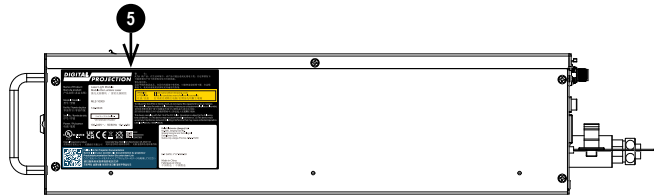

**MLS Left Side**

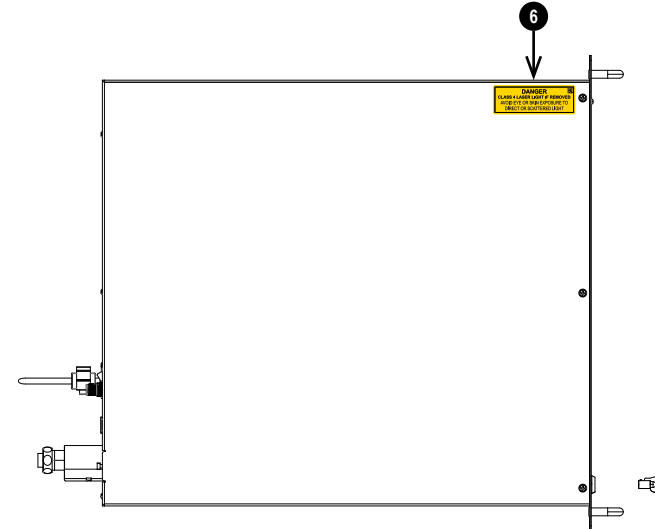

**MLS Top**

### Notes

**MLS 20000/MLS 30000 Label Locations**

1. Location of the Laser On Hazard Indicator Label on the front of the MLS.
2. Location of the Fiber Interface Label on the rear of the MLS.
3. Location of the FDA Standards Conformity Label on the rear of the MLS.
4. Location of the Light Hazard Explanatory Label on the rear of the MLS.
5. Location of the Manufacturer's ID Label on the left side of the MLS.
6. Location of the Compressor Transportation Warning on the left side of the MLS.
7. Location of the Internal Laser Warning Label on the top cover of the MLS.

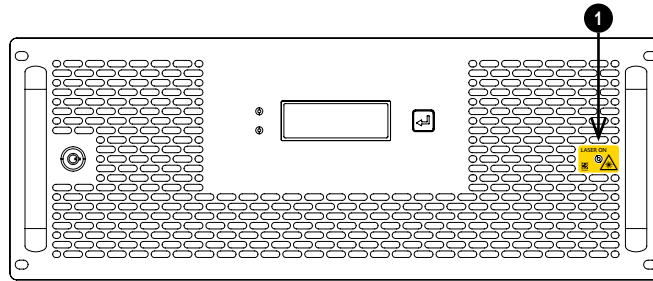
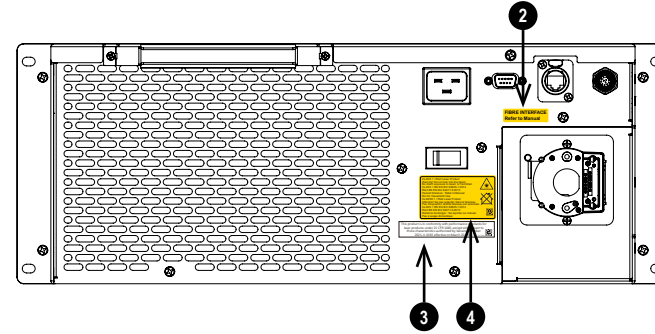
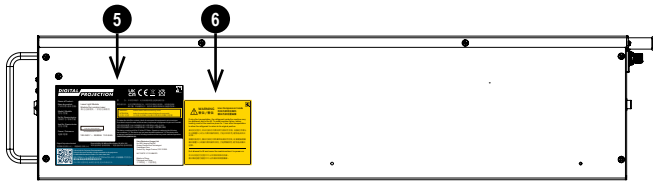
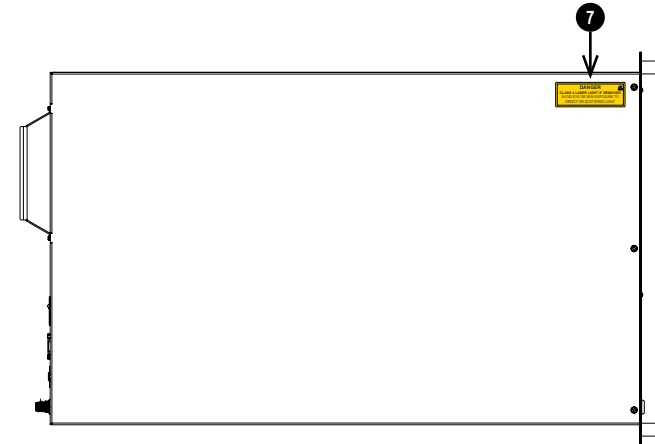
**MLS Front****MLS Rear****MLS Left Side****MLS Top****Notes**

## Satellite Control Module

### Notes



Manufacturers ID Label



Laser On Hazard Indicator Label

## Label Locations

1. Location of the Laser On Hazard Indicator Label on the front of the SCM.

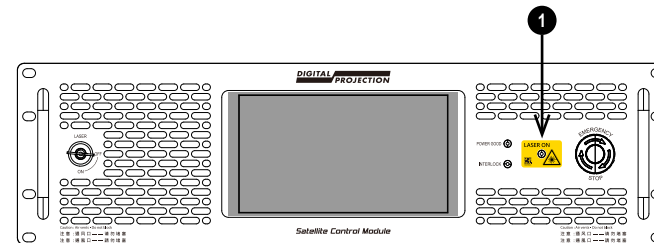

SCM Front

2. Location of the Manufacturer's ID Label on the left side of the SCM.

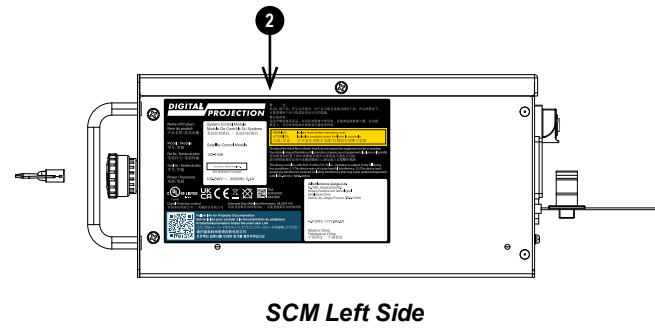

**Notes**

**Satellite Link Cable**



**Manufacturers ID Label**

### Label Locations

1. Location of the Manufacturer's ID Label on the opposite sides of the SLC label tag.

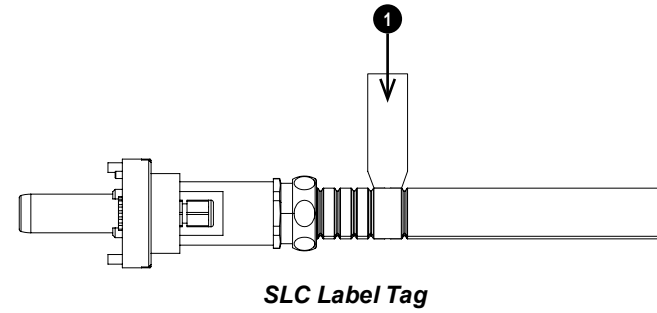

### Notes

## Appendix B: Choosing a lens

A number of lenses are available. Which lens you choose depends on the screen size, image aspect ratio, throw distance and light output.

The following table shows all available lenses in order of their throw ratios:

Throw ratios	Lens extension	Lens shift	Optimized focus range	Part number
0.37 : 1		V: 0.6 (U) 0.6 (D) frame H: 0.3 (L) 0.3 (R) frame	1.6 m - 4.9 m	120-510
0.67 : 1	185.9 mm	V: 0.1 (U) 0.1 (D) frame H: 0.04 (L) 0.04 (R) frame	1.1 m - 10 m	105-607
0.65 - 0.85: 1		V: 0.5 (U) 0.5 (D) frame H: 0.2 (L) 0.2 (R) frame	2.8 m - 8.4 m	120-511
1.12 : 1	249.9 mm	V: 0.567 (U) 0.45 (D) frame H: 0.188 (L) 0.188 (R) frame	3 m - 15 m	105-608
0.8 - 1.16 : 1		V: 0.4 (U) 0.4 (D) frame H: 0.19 (L) 0.19 (R) frame	1.7 m - 11 m	120-827
1.16 - 1.49:1	162.5 mm	V: 0.4 (U) 0.4 (D) frame H: 0.188 (L) 0.188 (R) frame	3 m - 15 m	109-236
1.39 - 1.87:1	130.5 mm	V: 0.567 (U) 0.45 (D) frame H: 0.188 (L) 0.188 (R) frame	4 m - 24 m	105-610
1.87 - 2.56:1	95.3 mm	V: 0.567 (U) 0.45 (D) frame H: 0.188 (L) 0.188 (R) frame	4 m - 24 m	105-611
2.56 - 4.16:1	88.7mm	V: 0.567 (U) 0.45 (D) frame H: 0.188 (L) 0.188 (R) frame	9.1 m - 45 m	105-612
4.16 - 6.96:1	55 mm	V: 0.567 (U) 0.45 (D) frame H: 0.188 (L) 0.188 (R) frame	12 m - 80 m	105-613
6.92 - 10.36:1	105 mm	Vt: 0.567 (U) 0.45 (D) frame H: 0.188 (L) 0.188 (R) frame	12 m - 80 m	109-235

To choose a lens, calculate the **throw ratio** required. Allow a tolerance of +/- 3% in the throw ratio calculation.

### Notes

*Throw distance calculations are based on the distance from the outer end of the lens, which varies from lens to lens.*

*The lens extension is the distance between the front of the projector chassis and the outer end of the lens when it is fully extended.*

*Refer to the projector CAD drawings for individual lens extension figures.*

## Basic calculation

Identify the required lens by calculating the **throw ratio**.

A **throw ratio** is the ratio of the throw distance **2** to the screen width **1**:

$$\text{ThrowRatio} = \text{ThrowDistance} / \text{ScreenWidth}$$

1. Use the formula above to obtain the required throw ratio.
2. Allow a tolerance of +/- 3% in the throw ratio calculation and match the throw ratio with a lens from the table below:

Throw ratios	Optimized focus range
0.37 : 1	1.6 m - 4.9 m
0.65 - 0.85: 1	2.8 m - 8.4 m
0.67 : 1	1.1 m - 10 m
0.8 - 1.16 : 1	1.7 m - 11 m
1.12 : 1	3 m - 15 m
1.16 - 1.49:1	3 m - 15 m
1.39 - 1.87:1	4 m - 24 m
1.87 - 2.56:1	4 m - 24 m
2.56 - 4.16:1	9.1 m - 45 m
4.16 - 6.96:1	12 m - 80 m
6.92 - 10.36:1	12 m - 80 m

3. Ensure the required throw distance is within the range covered by the lens.

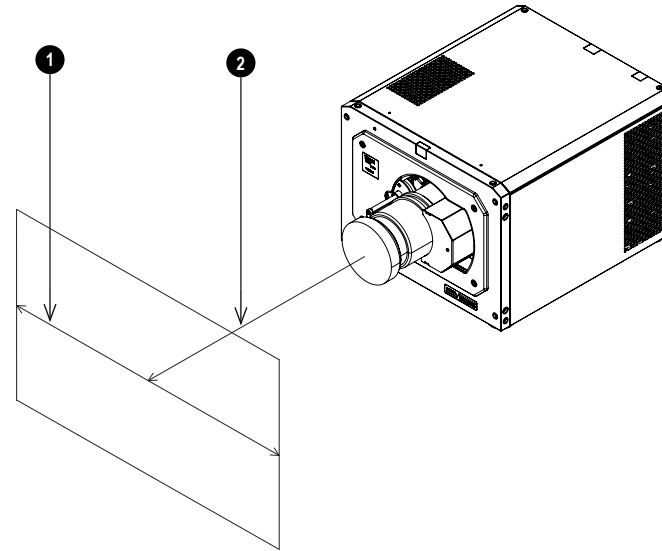

### Notes

The basic calculation on this page does not take into consideration DMD™ and image size, which could affect the throw ratio. See Full lens calculation on page 154 for a more complex and realistic calculation.

When calculating the throw ratio, be sure to use identical measurement units for both the throw distance and the screen width.

See Choosing a lens on the previous page for information about individual lens part numbers

**Basic calculation example**

1. Calculate the throw ratio using the formula.  
Your screen is **4.5m** wide and you wish to place the projector approximately **11m** from the screen. The throw ratio will then be  
 $11 \div 4.5 = \mathbf{2.44}$
2. Match the result with the lens table.  
The lens matching a throw ratio of 2.44 is the **1.87 - 2.56:1 lens**.
3. Check whether the lens covers the required throw distance.  
The focus range quoted for the 1.87 - 2.56:1 lens is **4 - 24m**. The required distance of 11m is within the range.

**INFORMATION YOU NEED FOR THIS CALCULATION**

The throw ratio formula:

$$\mathbf{ThrowRatio = ThrowDistance / ScreenWidth}$$

Allow a tolerance of +/- 3% in the throw ratio calculation.

The lens table:

Throw ratios	Optimized focus range
0.37 : 1	1.6 m - 4.9 m
0.65 - 0.85: 1	2.8 m - 8.4 m
0.67 : 1	1.1 m - 10 m
0.8 - 1.16 : 1	1.7 m - 11 m
1.12 : 1	3 m - 15 m
1.16 - 1.49:1	3 m - 15 m
1.39 - 1.87:1	4 m - 24 m
1.87 - 2.56:1	4 m - 24 m
2.56 - 4.16:1	9.1 m - 45 m
4.16 - 6.96:1	12 m - 80 m
6.92 - 10.36:1	12 m - 80 m

**Notes**

 The basic calculation on this page does not take into consideration DMD™ and image size, which could affect the throw ratio. See Full lens calculation on the next page for a more complex and realistic calculation.

 See Choosing a lens on page 151 for information about individual lens part numbers.

## Full lens calculation

### Introducing TRC

The choice of lens will affect the image size and will address discrepancies between the DMD™ resolution and the source.

When an image fills the height of the DMD™ but not the width, it uses less than 100% of the DMD™ surface. A lens chosen using the basic formula may produce an image that is considerably smaller than the actual screen.

To compensate for loss of screen space in such situations, you need to increase the throw ratio using a **Throw Ratio Correction (TRC)**.

### Example

**Fig. 1** illustrates a 4:3 image within a 16:9 display

When a 16:9 projector is used for a 4:3 image, the image does not fill the width of the DMD™, creating a **pillarboxing** effect - blank spaces to the left and right.

**Fig. 2** shows the same image projected on a 4:3 screen using a standard lens (chosen with the basic calculation).

The DMD™ accurately fills the width of the screen; however, the pillarboxing is now part of the projected image and is transferred to the screen.

The DMD™ does not fill the height of the screen, which has caused **letterboxing** - further blank spaces at the top and bottom of the screen.

The image is now surrounded by blank space, which can be removed if the throw ratio is increased.

**Fig. 3** shows the image projected on the same screen with a lens chosen using TRC. The increased throw ratio has allowed the 4:3 image to fill the 4:3 screen seamlessly



Fig 1

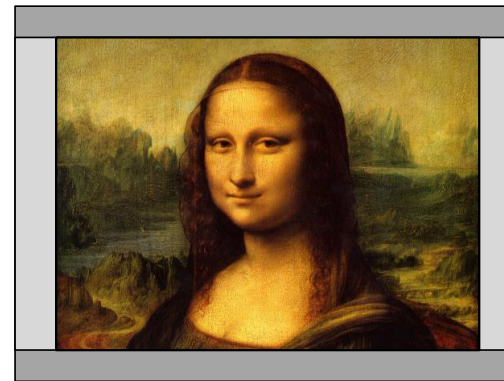



Fig 2



Fig 3

### Notes

 TRC can only be applied if greater than 1. If TRC is 1 or less, disregard it and calculate the throw ratio using the basic formula.

## Calculating TRC

To calculate TRC, use the following formula:

$$TRC = 1.6(DMD^{\text{TM}} \text{ AspectRatio}) / \text{Source AspectRatio}.$$

### TRC table

Alternatively, you can save time by referencing the following table, which shows the TRC value for some popular image formats:

<b>2.35:1 (Scope)</b>	1920 x 817 pixels	TRC < 1, not used
<b>1.85:1 (Flat)</b>	1920 x 1037 pixels	TRC < 1, not used
<b>1.78:1 (16:9)</b>	1920 x 1080 pixels	TRC < 1, not used
<b>1.6:1 (16:10)</b>	1920 x 1200 pixels	TRC < 1, not used (native aspect ratio)
<b>1.33:1 (4:3)</b>	1596 x 1200 pixels	TRC = 1.2
<b>1.25:1 (5:4)</b>	1500 x 1200 pixels	TRC = 1.28

## Calculating the throw ratio with TRC

- For TRC > 1, amend the basic throw ratio formula as follows:

$$\text{ThrowRatio} = \text{ThrowDistance} / \text{ScreenWidth} * TRC$$

Allow a tolerance of +/- 3% in the throw ratio calculation.

- Once a throw ratio is established, identify the matching lens from the table:

Throw ratios	Optimized focus range
0.37 : 1	1.6 m - 4.9 m
0.65 - 0.85: 1	2.8 m - 8.4 m
0.67 : 1	1.1 m - 10 m
0.8 - 1.16 : 1	1.7 m - 11 m
1.12 : 1	3 m - 15 m
1.16 - 1.49:1	3 m - 15 m
1.39 - 1.87:1	4 m - 24 m
1.87 - 2.56:1	4 m - 24 m
2.56 - 4.16:1	9.1 m - 45 m
4.16 - 6.96:1	12 m - 80 m
6.92 - 10.36:1	12 m - 80 m

- Ensure the required throw distance is within the range of the matching lens.

### Notes



TRC can only be applied if greater than 1. If TRC is 1 or less, disregard it and calculate the throw ratio using the basic formula.



Throw ratio for sources with a width of 3840 will be as the 4K-UHD ratio on the lens table.



TRC can only be applied if greater than 1. If TRC is 1 or less, disregard it and calculate the throw ratio using the basic formula.

## Full lens calculation example

Your screen is **4.5m** wide; you wish to place the projector approximately **11m** from the screen. The source is **4:3**.

1. Calculate TRC as follows:  
TRC = 1.6 / 1.33 = 1.2.
2. Calculate the throw ratio:  
Throw ratio = 11 / 4.5 x 1.2 = **2.04**
3. Allow a tolerance of +/- 3% in the throw ratio calculation and find a match in the lens table.  
The table shows that the matching lens is **the 1.87 - 2.56:1 lens**.
4. Check whether the lens covers the required throw distance.  
The focus range quoted for the 1.87 - 2.56:1 lens is **4m - 24m**. The required distance of 11 m is within the range.

### INFORMATION YOU NEED FOR THESE CALCULATIONS

The TRC formula

$$TRC = DMD^{\text{TM}} \text{ AspectRatio} / \text{Source AspectRatio}$$

The TRC table (to use instead of the formula)

<b>2.35:1 (Scope)</b>	TRC < 1, not used
<b>1.85:1 (Flat)</b>	TRC < 1, not used
<b>1.78:1 (16:9)</b>	TRC < 1, not used
<b>1.6:1 (16:10)</b>	TRC < 1, not used (native aspect ratio)
<b>1.33:1 (4:3)</b>	TRC = 1.2
<b>1.25:1 (5:4)</b>	TRC = 1.28

The throw ratio formula

$$ThrowRatio = ThrowDistance / ScreenWidth * TRC$$

Allow a tolerance of +/- 3% in the throw ratio calculation.

The lens table:

Throw ratios	Optimized focus range
0.37 : 1	1.6 m - 4.9 m
0.65 - 0.85: 1	2.8 m - 8.4 m
0.67 : 1	1.1 m - 10 m
0.8 - 1.16 : 1	1.7 m - 11 m
1.12 : 1	3 m - 15 m
1.16 - 1.49:1	3 m - 15 m
1.39 - 1.87:1	4 m - 24 m
1.87 - 2.56:1	4 m - 24 m
2.56 - 4.16:1	9.1 m - 45 m
4.16 - 6.96:1	12 m - 80 m
6.92 - 10.36:1	12 m - 80 m

## Notes

## Appendix C: Screen requirements

### Fitting the image to the display

If the source image supplied to the projector is smaller than the WUXGA resolution, the image will not fill the display. The following examples show how a number of common formats may be displayed, depending on your DMD™ resolution.

#### Images displayed full width of 1920 pixels

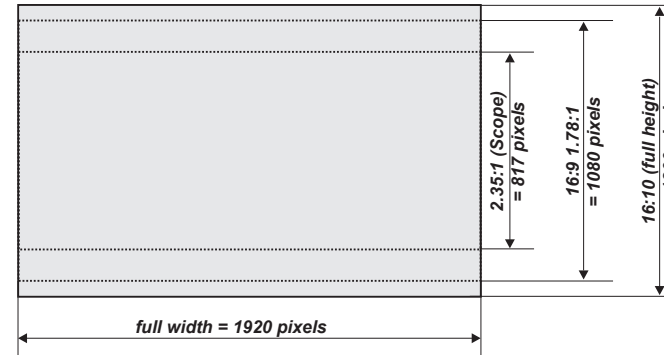

#### Images displayed with a height of 1200 pixels

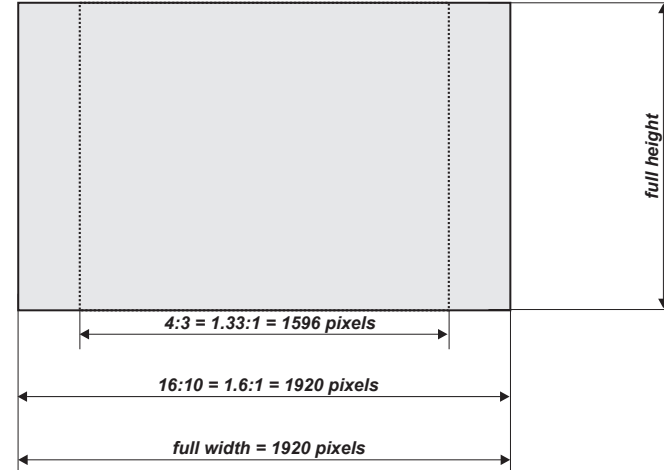

**Notes**

**Images displayed full height of 1200 pixels**

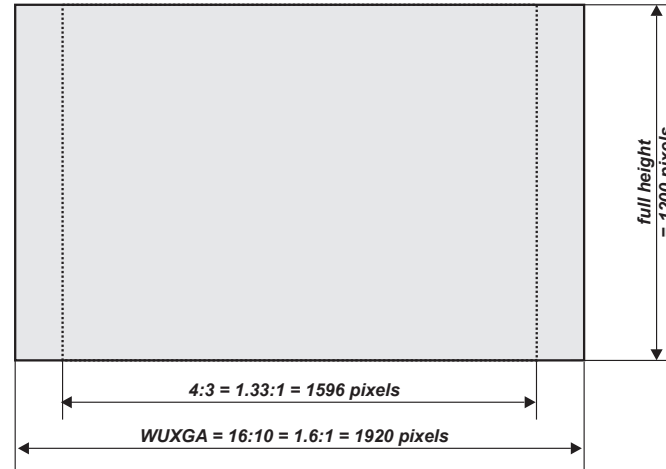

**Notes**

**Diagonal screen sizes**

Screen sizes are sometimes specified by their diagonal size (D). When dealing with large screens and projection distances at different aspect ratios, it is more convenient to measure screen width (W) and height (H).

The example calculations below show how to convert diagonal sizes into width and height, at various aspect ratios.

**2.35:1 (Scope)**

$W = D \times 0.92$   $H = D \times 0.39$

**1.85:1**

$W = D \times 0.88$   $H = D \times 0.48$

**16:9 = 1.78:1**

$W = D \times 0.87$   $H = D \times 0.49$

**16:10 = 1.6:1 (native aspect ratio for WUXGA projectors)**

$W = D \times 0.85$   $H = D \times 0.53$

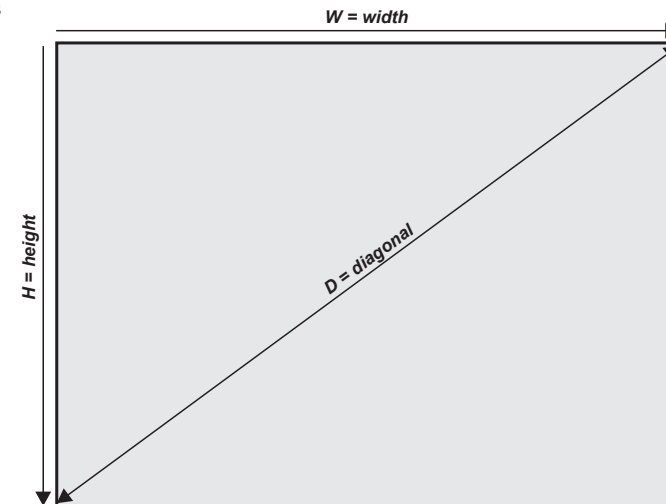

## Appendix D: Positioning the image

The normal position for the projector is at the center of the screen. However, you can set the projector above or below the center, or to one side, and adjust the image using the **Lens shift** feature (known as **rising and falling front**) to maintain a geometrically correct image.

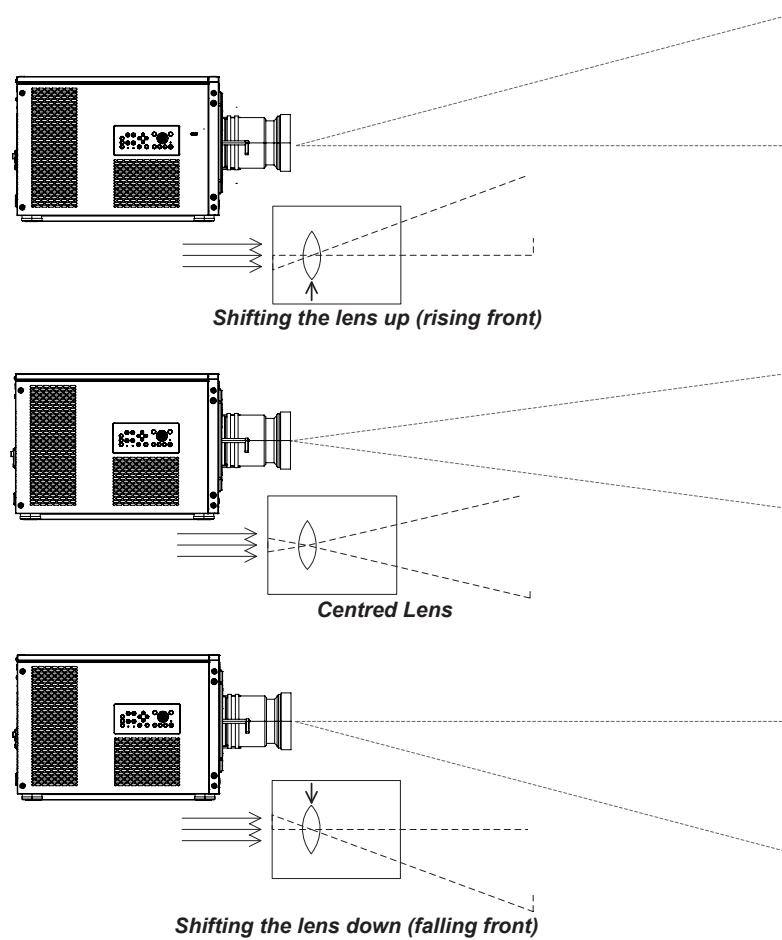

### Notes



*Whenever possible, position the projector so that the lens is centered for the highest quality image*

Any single adjustment outside the ranges specified on the following page may result in an unacceptable level of distortion, particularly at the corners of the image, due to the image passing through the periphery of the lens optics.

If the lens is to be shifted in two directions combined, the maximum range without distortion will be somewhat less, as can be seen in the illustrations.

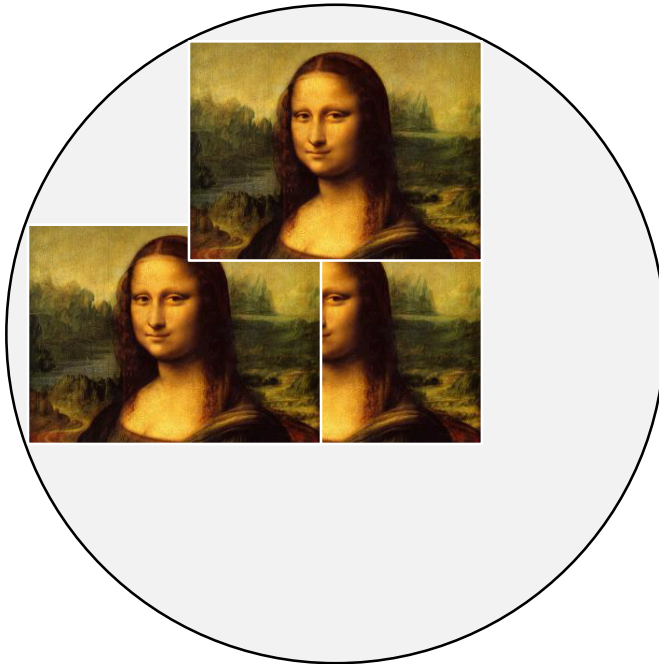

*Full horizontal or vertical shift*

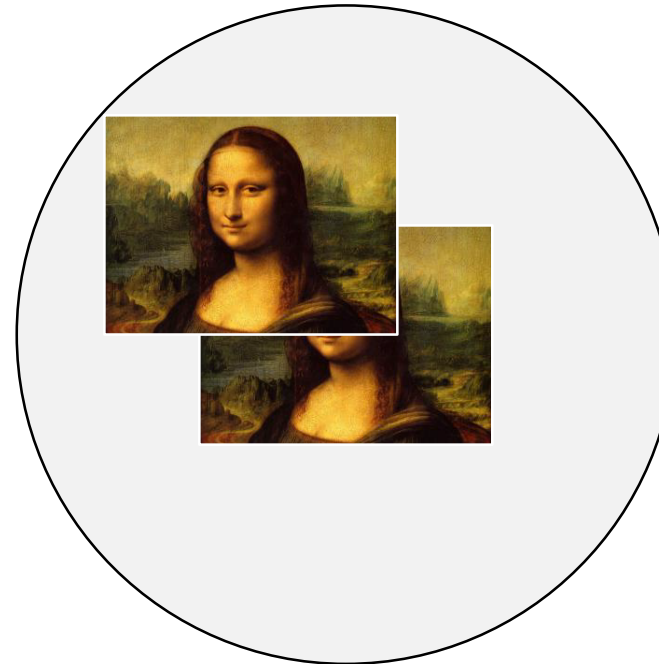

*Combined shift is reduced*

**Notes**

## Appendix E: Aspect ratios explained

The appearance of a projected image on the screen depends on a combination of the following:

- The display resolution: **WUXGA** with a 1200 x 1920 resolution, corresponding to an aspect ratio of 16:10
- The aspect ratio of the input signal: usually **4:3**, **16:9** or **16:10**
- The value of the **Aspect Ratio** setting of the projector:
  - **16:9**, **4:3**, and **5:4** stretch the image to the selected aspect ratio. **16:9** leaves black bars at the top and bottom of the screen (letterboxing effect); **4:3** and **5:4** leave black bars at the sides of the screen (pillarboxing).
  - **Source** shows the image with its original aspect ratio, if this does not match the native aspect ratio of the DMD™, then the image will be scaled to either fit the full width or height of the display.

### Aspect ratios examples

1. Unused screen areas

**Source: 4:3**

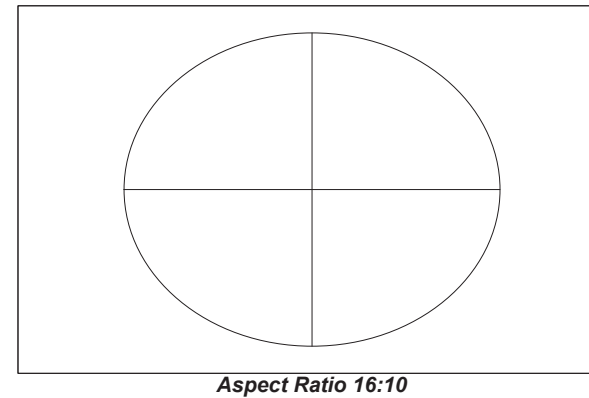
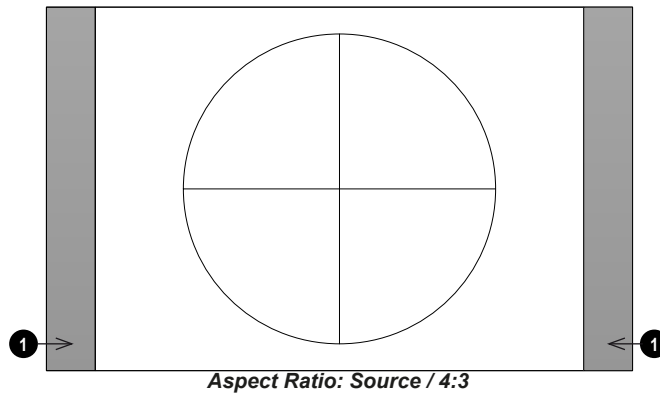

**Notes**

**Source: 16:9**

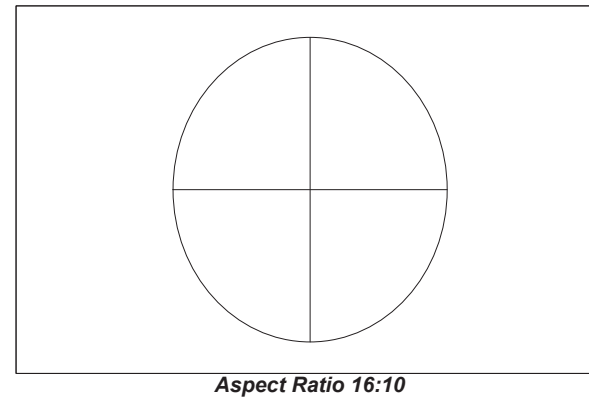
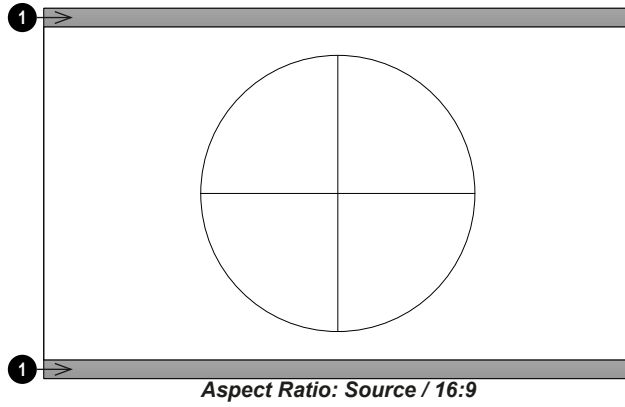

**Source: 16:10 (native)**

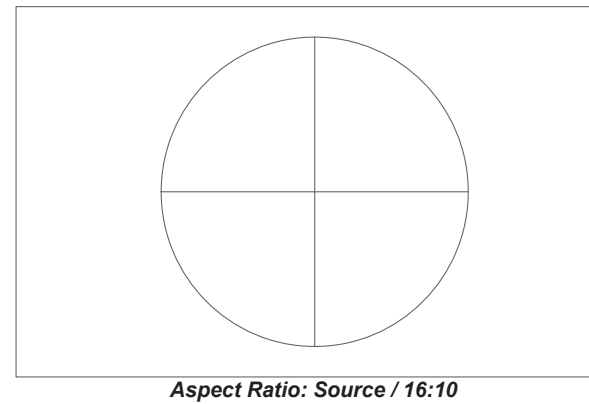

**Notes**

## Aspect ratio example: TheatreScope

The TheaterScope setting is used in combination with an anamorphic lens to restore 2.35:1 images packed into a 16:9 frame. Such images are projected with black lines at the top and bottom of the 16:9 screen to make up for the difference in aspect ratios.

Without an anamorphic lens and without the TheaterScope setting applied, a 16:9 source containing a 2.35:1 image looks like this:

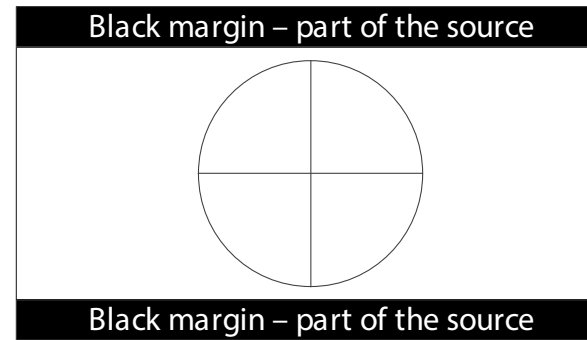

If we change the setting to TheaterScope, the black lines will disappear but the image will stretch vertically to reach the top and bottom of the DMD™:

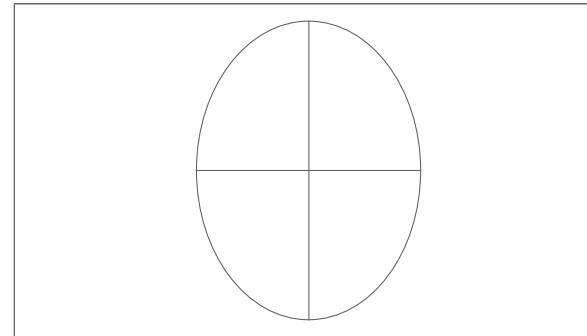

An anamorphic lens will stretch the image horizontally, restoring the original 2.35 ratio:

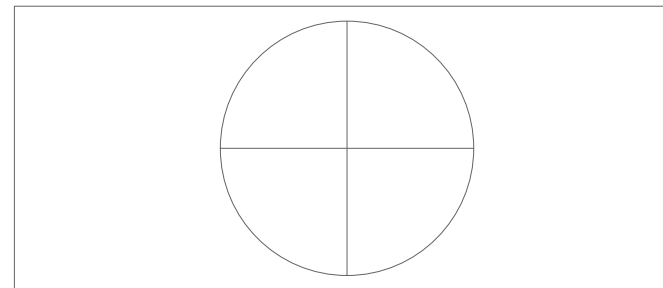





**Notes**

## Appendix F: Supported signal input modes

### 2D formats

Signal Format	Resolution	Frame Rate (Hz)	Display Port	HDMI / HD-BaseT				Output Frame Rate (Hz)
				RGB	YUV 8-bit	YUV 10-bit	YUV 12-bit	
PC	640 x 480	60	✓	✓				120
	640 x 480	75	✓	✓				120
	640 x 480	85	✓	✓				120
	800 x 600	60	✓	✓				120
	800 x 600	75	✓	✓				120
	800 x 600	85	✓	✓				120
	848 x 480	48	✓	✓				96
	848 x 480	60	✓	✓				120
	1024 x 768	60	✓	✓				120
	1024 x 768	75	✓	✓				120
	1024 x 768	85	✓	✓				120
	1280 x 720	48	✓	✓				96
	1280 x 768	60	✓	✓				120
	1280 x 800	60	✓	✓				120
	1280 x 960	60	✓	✓				120
	1280 x 1024	60	✓	✓				120
	1280 x 1024	75	✓	✓				120
	1280 x 1024	85	✓	✓				120
	1366 x 768	60	✓	✓				120
	1440 x 900	60	✓	✓				120
	1400 x 1050	60	✓	✓				120
	1600 x 1200	60	✓	✓				120
	1680 x 1050	60	✓	✓				120
	1920 x 1080	48	✓	✓				96
	1920 x 1200 RB	50	✓	✓				100
	1920 x 1200 RB	60	✓	✓				120
	1920 x 1080	100	✓	✓*4				100
	1920 x 1080	120	✓	✓*4				120
	1920 x 1200	100	✓	✓*4				100
	1920 x 1200 RB	120	✓	✓*4				120
Apple Mac	640 x 480	67	✓	✓				120
	832 x 624	75	✓	✓				120

### Notes

-  \*1 HDBaseT supports 4K 24/25/30Hz 4:2:2 only (No HDR support)
-  \*2 HDBaseT does not supports 4K 50/60Hz.
-  \*3 HDMI support up to 4:2:2, HDBaseT does not support
-  \*4 HDMI support but HDBaseT does not support

Signal Format	Resolution	Frame Rate (Hz)	Display Port	HDMI / HD-BaseT				Output Frame Rate (Hz)
				RGB	YUV 8-bit	YUV 10-bit	YUV 12-bit	
SDTV	1440x480i	60.00		✓	✓	✓	✓	120
	1440x576i	50.00		✓	✓	✓	✓	100
EDTV	480p	59.94	✓	✓	✓	✓	✓	120
	576p	50.00	✓	✓	✓	✓	✓	100
HDTV	1035i	60.00	✓	✓	✓	✓	✓	120
	1080i	50.00	✓	✓	✓	✓	✓	100
	1080i	59.94	✓	✓	✓	✓	✓	120
	1080i	60.00	✓	✓	✓	✓	✓	120
	720p	50.00	✓	✓	✓	✓	✓	100
	720p	59.94	✓	✓	✓	✓	✓	120
	720p	60.00	✓	✓	✓	✓	✓	120
	1080p	23.98	✓	✓	✓	✓	✓	96
	1080p	24.00	✓	✓	✓	✓	✓	96
	1080p	25.00	✓	✓	✓	✓	✓	120
	1080p	29.97	✓	✓	✓	✓	✓	120
	1080p	30.00	✓	✓	✓	✓	✓	120
	1080p	50.00	✓	✓	✓	✓	✓	100
	1080p	59.94	✓	✓	✓	✓	✓	120
	1080p	60.00	✓	✓	✓	✓	✓	120
	2K (2048x1080)	24	✓	✓	✓	✓	✓	96
	2K (2048x1080)	25	✓	✓	✓	✓	✓	100
	2K (2048x1080)	30	✓	✓	✓	✓	✓	120
	2K (2048x1080)	50	✓	✓	✓	✓	✓	100
	2K (2048x1080)	60	✓	✓	✓	✓	✓	120
	4K-UHD (3840x2160)	24	✓	✓	✓	✓*1	✓*1	96
	4K-UHD (3840x2160)	25	✓	✓	✓	✓*1	✓*1	100
	4K-UHD (3840x2160)	30	✓	✓	✓	✓*1	✓*1	120
4K-UHD (3840x2160)	50	✓(8 bits)	✓(8 bits)	✓*2	✓*3	✓*3	100	
4K-UHD (3840x2160)	60	✓(8 bits)	✓(8 bits)	✓*2	✓*3	✓*3	120	

Notes

## Appendix G: Wiring details

### Signal inputs and outputs

#### HDMI

19 way type A connector

1. TMDS Data 2+
2. TMDS Data 2 Shield (Ground)
3. TMDS Data 2-
4. TMDS Data 1+
5. TMDS Data 1 Shield (Ground)
6. TMDS Data 1-
7. TMDS Data 0+
8. TMDS Data 0 Shield (Ground)
9. TMDS Data 0-
10. TMDS Clock+
11. TMDS Clock Shield (Ground)
12. TMDS Clock-
13. CEC
14. not connected
15. SCL (DDC Clock)
16. SCA (DDC Data)
17. DDC/CEC Shield (Ground)
18. +5 V Power
19. Hot Plug Detect

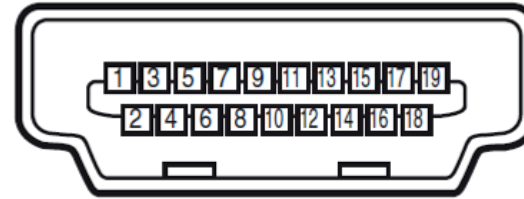

*HDMI: pin view of panel connector*

**Notes**

## DisplayPort

### DisplayPort 1.2

Pin 1	ML_Lane 0 (p)	Lane 0 (positive)
Pin 2	GND	Ground
Pin 3	ML_Lane 0 (n)	Lane 0 (negative)
Pin 4	ML_Lane 1 (p)	Lane 1 (positive)
Pin 5	GND	Ground
Pin 6	ML_Lane 1 (n)	Lane 1 (negative)
Pin 7	ML_Lane 2 (p)	Lane 2 (positive)
Pin 8	GND	Ground
Pin 9	ML_Lane 2 (n)	Lane 2 (negative)
Pin 10	ML_Lane 3 (p)	Lane 3 (positive)
Pin 11	GND	Ground
Pin 12	ML_Lane 3 (n)	Lane 3 (negative)
Pin 13	CONFIG1	Connected to Ground1
Pin 14	CONFIG2	Connected to Ground1
Pin 15	AUX CH (p)	Auxiliary Channel (positive)
Pin 16	GND	Ground
Pin 17	AUX CH (n)	Auxiliary Channel (negative)
Pin 18	Hot Plug	Hot Plug Detect
Pin 19	Return	Return for Power
Pin 20	DP_PWR	Power for connector (3.3 V 500 mA)

### HDBaseT input

RJ45 socket.

1. DATA 0+
2. DATA 0-
3. DATA 1+
4. DATA 2+
5. DATA 2-
6. DATA 1-
7. DATA 3+
8. DATA 3-

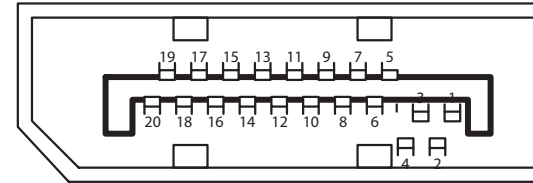

**DisplayPort: pin view of panel connector**

### Notes

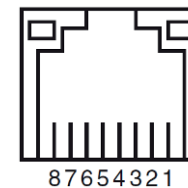

87654321

**HDBase-T**

## Control connections

### LAN

RJ45 socket

1. TX+
2. TX-
3. TXC
4. Ground
5. Ground
6. RXC
7. RX+
8. RX-

### RS232

9 way D-type connector

1. not connected
2. Received Data (RX)
3. Transmitted Data (TX)
4. not connected
5. Ground
6. not connected
7. Short with pin8
8. Short with pin7
9. not connected

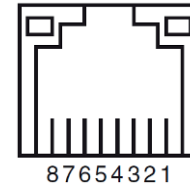

**LAN: pin view of panel connector**

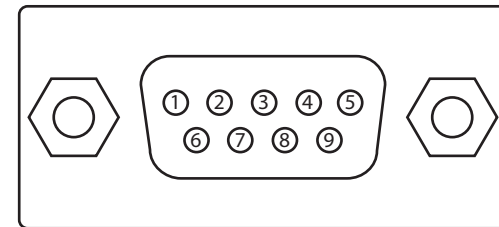

**RS232: pin view of panel male connector**

### Notes

 Only one remote connection (RS232 or LAN) should be used at any one time.

## Appendix H: Cleaning the SLC

Repeated installations and device changes may expose the surface of the optical fiber in the SLC to dirt and other contaminants.

Prolonged use of a contaminated SLC may damage the SLC. It is important to clean the SLC to maintain the performance of the SLC.

The SLC connectors should be cleaned every time they are connected to a device.

The basics of cleaning:

1. Use a pure grade of isopropyl alcohol on a clean lint-free tissue to wipe the end face of the SLC and the connector.
2. Wipe the surfaces with a dry lint-free tissue. Do not allow the surface to air dry.
3. Inspect the connector to make sure it is clean. Repeat cleaning if necessary.

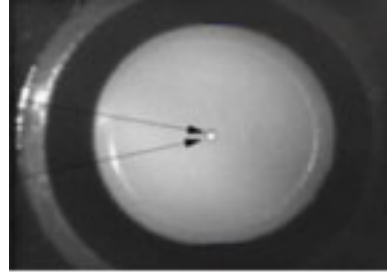

**Example of a clean SLC**

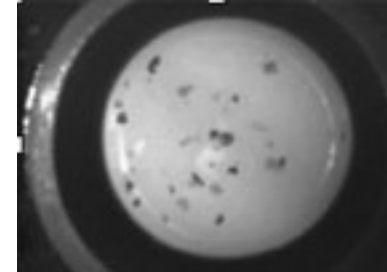



**Example of a dirty SLC**



**Example of a damaged SLC**

### Notes

 You can use a 100x illuminated microscope (fiberscope) to inspect the connector.

 Contact a Digital Projection service center for further information on cleaning and cleaning products.

## Appendix I: Memory scheme and memory items

Notes

Below is a summary of the OSD parameters that can be saved in the memory presets.

### Satellite Head

Item	Global Memory	Per Input Memory (Preset A/B/C/D)	Remark
Input Select	☉		
Resync			Not Memorized
Test Pattern			Not Memorized
Auto Source	☉		
EDID Mode	☉		
Lens Lock / Lens Memory	☉		
Smooth Picture	☉		Unavailable if no signal (signal = Searching) (Only available for 4K Model)
Gamma		☉	Will apply the general gamma when HDR is not activated.
HDR Mode		☉	Will apply the gamma for HDR when auto detected the HDR signal or manual select the PQ-400/PQ-500/PQ-1000/HLG option.
Brightness		☉	
Contrast		☉	
Saturation		☉	
Hue		☉	
Sharpness		☉	
Noise Reduction		☉	
Freeze			Not Memorized
Ambient Brightness Correction		☉	
Dynamic Contrast		☉	not CBC on, not test pattern on, Only support full on/ full off and base on "Light off timer" define black image keep time to active.
Light Off Timer		☉	Available when Dynamic Contrast is set at ON, ' not CBC on, not test pattern on
Color Space		☉	
Color Mode		☉	
ColorMax		☉	When Color Mode is selected at ColorMax option.
Manual Color Matching		☉	When non-HDR and the Color Mode is selected at Manual Color Matching option.
		☉	When HDR and the Color Mode is selected at Manual Color Matching option.
Color Temperature		☉	When Color Mode is selected at Color Temperature option.

Item	Global Memory	Per Input Memory (Preset A/B/C/D)	Remark	Notes
Red Lift		⊙	When Color Mode is selected at Gains and Lifts option.	
Green Lift		⊙		
Blue Lift		⊙		
Red Gain		⊙		
Green Gain		⊙		
Blue Gain		⊙		
Aspect ratio		⊙		
Digi Zoom			Not Memorized and reset to 0 after power cycle	
Digi Pan				
Digi Scan				
OverScan		⊙		
Blanking	⊙			
Orientation	⊙			
High Altitude	⊙			
Startup Logo	⊙			
Blank Screen	⊙			
Pic.Mute Setting	⊙			
Smear Reduction	⊙		4K Model: Only available in WUXGA mode(SP Off). WU Model: Available.	
Output Frame Rate	⊙			
HDMI Equalizer	⊙			
Screen Setting	⊙			
Auto Poweroff	⊙			
Auto Poweron	⊙			
Schedule Setting	⊙			
Instant Startup	⊙			
Standby Period	⊙			
ColorMax Setting	⊙			
Ir Enable	⊙			
Ir Code	⊙			
Hotkey Setting	⊙			
Keypad Backlight	⊙			
OSD Language	⊙			
OSD Menupos	⊙			
OSD Trans	⊙			
OSD Timer	⊙			

Item	Global Memory	Per Input Memory (Preset A/B/C/D)	Remark
Lan IP	⊙		When SCM enable, those network setting function may disable and will only show up information.
Lan Subnet	⊙		
Lan MAC	⊙		

**MLS**

Item	Global Memory	Per Input Memory (Preset A/B/C/D)	Remark
Power Mode	⊙		
Power Level	⊙		
Contrast Brightness	⊙		
OSD Language	⊙		
MUBC	⊙		
Lan IP	⊙		When SCM enable, those network setting function may disable and will only show up information.
Lan Subnet	⊙		
Lan MAC	⊙		

**SCM**

Item	Global Memory	Per Input Memory (Preset A/B/C/D)	Remark
Lan DHCP	⊙		
Lan IP	⊙		
Lan Subnet	⊙		

**Notes**

## Appendix J: Served web pages

The served web pages allow you to control the system remotely via Ethernet. The controls replicate some or all of the functions available in the OSD, or the touchscreen control panels on each Satellite module.

The device you use to access the served web pages must be connected to the same network as the SCM. Use a web browser to access the served web pages.

The default IP address is **192.168.0.100**.

A user name and password may be required to access the served web pages for the projector via a web browser.

- The user name is "admin". This cannot be changed.
- The default password is "1234".

The home page for the served web pages is the system configuration page. Use this page to access the controls for each individual module:

- The system controller menu provides access to the controls on the SCM touchscreen.
- **Component 1, Component 2, Component 3, Component 4, Component 5.** Each component menu provides information about the other modules installed in the system. This could be 1-3 MLS and 1 Satellite Head or 1 MLS and 1-4 Satellite Heads. Click the menu icon in the header to enable the link to the component menus. Click on a component menu open its touchscreen menus and access various settings.

A Satellite Head component menu provides access to the controls on the Satellite Head touchscreen.

Refer to the operating guide for the Satellite Head for guidance on using the menus. Click the close icon in the header to go back to the top level web served menu.

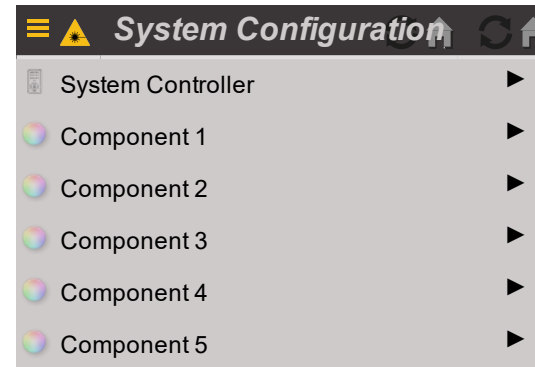

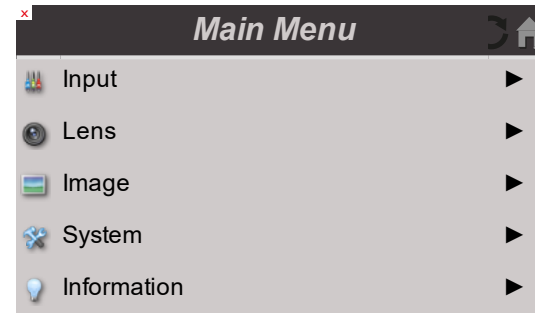

**Web Served Screen Display: Top Level Menu**





**Satellite Head Touchscreen Display: Top Level Menu**

### Notes

 See Control connections on page 1 for guidance on connecting to the projector via Ethernet.

 See Introduction to the OSD on page 86 for guidance on the available controls for this system. See Introduction to the MLS 10000 Touchscreen on page 122. See Introduction to the SCM Touchscreen on page 1.

 The IP address for the system can be changed on the SCM. See Network on page 134.

 We recommend that you change the default password. The password can be changed in the OSD. See Web Served OSD on page 115.

A SCM component menu provides access to the controls on the SCM touchscreen.

Refer to the operating guide for the SCM for guidance on using the menus. Click the close icon in the header to go back to the top level web served menu.

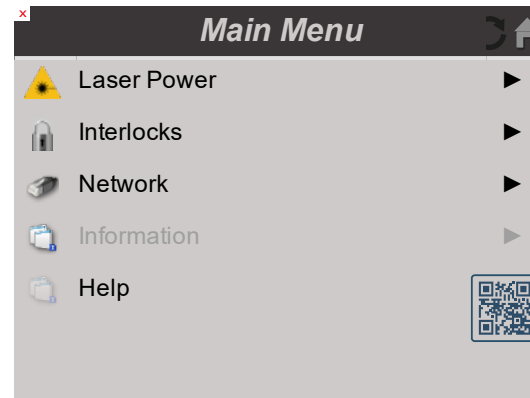

**SCM Touchscreen Display: Top Level Menu**

**Notes**

**Appendix K: Glossary of terms****Notes****1****1080p**

An HDTV resolution which corresponds to 1920 x 1080 pixels (a widescreen aspect ratio of 16:9).

**3****3D active glasses**

Wireless battery-powered glasses with LCD shutters. Synchronization information is communicated to the glasses by means of an infrared (IR) or radio frequency (RF) emitter which is connected to the Sync Out terminal on the projector. IR or RF pulses are transmitted by the emitter to signal when the left eye and right eye images are being displayed. The glasses incorporate a sensor which detects the emitter's signal and synchronizes the left and right eye shutters with the projected image.

**3D passive glasses**

Passive glasses do not require a power source to work. Light with left-hand polarization can pass through the left lens and light with right hand polarization can pass through the right-hand lens. These glasses are used in conjunction with another device which polarizes the image, such as a ZScreen.

**4****4K-UHD**

The 4K-UHD resolution of 3840 × 2160 is the dominant 4K resolution used in the consumer media and display industries. This resolution has an aspect ratio of 16 :9, with 8,294,400 total pixels.

**A****Adjust lines**

A pattern applied to the image where its edge is to be blended with another image. Adjust lines are used to position the projectors in the array during the edge blend process.

**Anamorphic lens**

A special lens which, when used with the TheaterScope aspect ratio, allows watching 2.35:1 content packed in a 16:9 source.

**Aperture**

The opening of the lens that determines the angle through which light travels to come into focus.

**Aspect ratio**

The proportional relationship between the width and the height of the projected image. It is represented by two numbers separated by a colon, indicating the ratio of image width and height respectively: for example, 16:9 or 2.35:1. Not to be confused with resolution.

**B****Blanking (projection)**

The ability to intentionally turn off, that is, set to black, areas around the edges of the projected image. It is sometimes referred to as “curtains” since it can be used to blank an area of image that literally falls on the curtains at the side of the screen in a movie theater. Usually no image resizing or geometric correction takes place and the “blanked” part of the image is lost. Not to be confused with horizontal and vertical blanking (video signal).

**Blanking (video signal)**

The section of the video signal where there is no active video data. Not to be confused with blanking (projection).

**Blend region**

The area of the image that is to overlap with another image in an edge blend setup. Sometimes called overlapping region.

**Brightness (electronic control)**

A control which adds a fixed intensity value to every pixel in the display, moving the entire range of displayed intensities up or down, and is used to set the black point in the image (see Contrast). In Component Video signals, brightness is the same as luminance.

**Brightness (optical)**

Describes how ‘bright’ an image that is projected onto a screen appears to an observer.

**C****C**

Also known as ‘Chrominance’, this is the component, or pair of components, of a Component Video signal which describes color difference information.

**Chrominance**

Also known as ‘C’, this is the component, or pair of components, of a Component Video signal which describes color difference information.

**Color difference**

In Component Video signals, the difference between specified colors and the luminance component. Color difference is zero for monochrome images.

**Color gamut**

The spectrum of color available to be displayed.

**Color temperature**

The position along the black body curve on the chromaticity diagram, normally quoted in Kelvin. It takes into account the preset values for color balance in the service set-up to take up the variations in the prism. The projector allows you to adjust this temperature (i.e. adjust the picture color temperature).

**Notes**

**Component video**

A three-wire or four-wire video interface that carries the signal split into its basic RGB components or luminance (brightness) and two-color difference signals (YUV) and synchronization signals.

**Contrast (electronic control)**

The adjustment of the white point of the image without affecting the black point. This increases the intensity range of the displayed image.

**Contrast (optical)**

The intensity difference between the darkest and lightest areas of the screen.

**Cr, Cb**

Color difference signals used with 'Y' for digital Component Video inputs. They provide information about the signal color. Not to be confused with Pr, Pb.

**Crop**

Remove part of the projected image. Alternatively, fit an image into a frame with a different aspect ratio by removing part of the image. The image is resized so that either its length or its width equals the length or width of the frame, while the other dimension has moved outside the frame; the excess area is then cut out.

---

**D****Dark time**

The time inserted between frames when using 3D active glasses, to avoid ghosting caused by switching time between left and right eye.

**DDC (Display Data Channel)**

A communications link between the source and projector. DDC is used on the HDMI, DVI and VGA inputs. The link is used by the source to read the EDID stored in the projector.

**Deinterlacing**

The process of converting interlaced video signals into progressive ones.

**DHCP (Dynamic Host Configuration Protocol)**

A network protocol that is used to configure network devices so that they can communicate on an IP network, for example by allocating an IP address.

**DMD™ (Digital Micromirror Device™)**

The optical tool that transforms the electronic signal from the input source into an optical image projected on the screen. The DMD™ of a projector has a fixed resolution, which affects the aspect ratio of the projected image. A Digital Micromirror Device™ (DMD™) consists of moving microscopic mirrors. Each mirror, which acts as a pixel, is suspended between two posts by a thin torsion hinge. It can be tilted to produce either a bright or dark pixel.

**Notes**

## E

---

### Edge blend

A method of creating a combined image by blending the adjoining edges of two or more individual images.

### Edge tear

An artifact observed in interlaced video where the screen appears to be split horizontally. Edge tears appear when the video feed is out of sync with the refresh rate of the display device.

### EDID (Extended Display Identification Data)

Information stored in the projector that can be read by the source. EDID is used on the HDMI, DVI and VGA inputs, allowing the source to automatically configure to the optimum display settings.

### EDTV (Enhanced Definition Television)

A progressive digital television system with a lower resolution than HDTV.

## F

---

### Field

In interlaced video, a part of the image frame that is scanned separately. A field is a collection of either all the odd lines or all the even lines within the frame.

### Frame

One of the many still images displayed in a sequence to create a moving picture. A frame is made of horizontal lines of pixels. For example, a 1920x1080 frame consists of 1080 lines, each containing 1920 pixels. In analog video frames are scanned one at a time (progressive scanning) or split into fields for each field to be scanned separately (interlaced video).

### Frame rate

The number of frames shown per second (fps). In TV and video, a frame rate is the rate at which the display device scans the screen to “draw” the frame.

### Frame rate multiplication

To stop low frame rate 3D images from flickering, frame rate multiplication can be used, which increases the displayed frame rate by two or three times

## G

---

### Gamma

A nonlinear operation used to code and decode luminance. It originates from the Cathode Ray Tube technology used in legacy television sets.

### Ghosting

An artifact in 3D image viewing. Ghosting occurs when an image intended for one eye is partially seen by the other eye. Ghosting can be removed by optimizing the dark time and sync delay.

**Notes**

## H

---

**HDCP (High-bandwidth Digital Content Protection)**

An encryption scheme used to protect video content.

**HDTV (High Definition Television)**

A television system with a higher resolution than SDTV and EDTV. It can be transmitted in various formats, notably 1080p and 720p.

**Hertz (Hz)**

Cycles per second.

**Horizontal Scan Rate**

The rate at which the lines of the incoming signal are refreshed. The rate is set by the horizontal synchronization from the source and measured in Hertz.

**Hs + Vs**

Horizontal and vertical synchronization.

**Hue**

The graduation (red/green balance) of color (applicable to NTSC).

## I

---

**Interlacing**

A method of updating the image. The screen is divided in two fields, one containing every odd horizontal line, the other one containing the even lines. The fields are then alternately updated. In analog TV interlacing was commonly used as a way of doubling the refresh rate without consuming extra bandwidth.

**Interleaving**

The alternation between left and right eye images when displaying 3D.

## L

---

**LED (Light Emitting Diode)**

An electronic component that emits light.

**Letterboxing**

Black margins at the top and bottom of the image. Letterboxing appears when a wider image is packed into a narrower frame without changing the original aspect ratio.

**Notes**

**Lumen**

A photometric unit of radiant power. For projectors, it is normally used to specify the total amount of emitted visible light.

**Luminance**

Also known as 'Y', this is the part of a Component Video signal which affects the brightness, i.e. the black and white part.

**N**

---

**Noise**

Electrical interference displayed on the screen.

**NTSC (National Television Standards Committee)**

The United States standard for television - 525 lines transmitted at 60 interlaced fields per second

**O**

---

**OSD (on-screen display)**

The projector menus allowing you to adjust various settings.

**Overlapping region**

The area of the image that is to overlap with another image in an edge blend setup. Sometimes called overlapping region.

**P**

---

**PAL (Phase Alternate Line)**

The television system used in the UK, Australia and other countries - 625 lines transmitted at 50 interlaced fields per second.

**Pillarboxing**

Black margins at the left and right of the image. Pillarboxing appears when a narrower image is packed into a wider frame without changing the aspect ratio.

**Pixel**

Short for Picture Element. The most basic unit of an image. Pixels are arranged in lines and columns. Each pixel corresponds to a micromirror within the DMD™; resolutions reflect the number of pixels per line by the number of lines. For example, a 1080p projector contains 1080 lines, each consisting of 1920 pixels.

**Pond of mirrors**

Area around the periphery of the DMD™ containing inactive mirrors. The pond of mirrors may cause artifacts, for example during the edge blending process.

**Notes**

**Pr, Pb**

Color difference signals used with 'Y' for analog Component Video inputs. They provide information about the signal color. Not to be confused with Cr, Cb.

**Primary colors**

Three colors any two of which cannot be mixed to produce the third. In additive color television systems the primary colors are red, green and blue.

**Progressive scanning**

A method of updating the image in which the lines of each frame are drawn in a sequence, without interlacing.

**Pulldown**

The process of converting a 24 fps film footage to a video frame rate (25 fps for PAL/SECAM, 30 fps for NTSC) by adding extra frames. DP projectors automatically carry out reverse pulldown whenever possible.

**R****Resolution**

The number of pixels in an image, usually represented by the number of pixels per line and the number of lines (for example, 1920 x 1200).

**RGB (Red, Green and Blue)**

An uncompressed Component Video standard.

**S****Saturation**

The amount of color in an image.

**Scope**

An aspect ratio of 2.35:1.

**SDTV (Standard Definition Television)**

An interlaced television system with a lower resolution than HDTV. For PAL and SECAM signals, the resolution is 576i; for NTSC it is 480i.

**SECAM (Sequential Color with Memory)**

The television system used in France, Russia and some other countries - 625 lines transmitted at 50 interlaced fields per second.

**Smooth picture**

A feature that can display a higher resolution source than the native resolution of the projector without losing any pixel data.

**SX+**

A display resolution of 1400 x 1050 pixels with a 4:3 screen aspect ratio. (Shortened from SXGA+, stands for Super Extended Graphics Array Plus.)

**Notes**

**Synchronization**

A timing signal used to coordinate an action.

**T**

---

**Test pattern**

A still image specially prepared for testing a projection system. It may contain various combinations of colors, lines and geometric shapes.

**TheaterScope**

An aspect ratio used in conjunction with a special anamorphic lens to display 2.35:1 images packed into a 16:9 frame.

**Throw distance**

The distance between the screen and the projector.

**Throw ratio**

The ratio of the throw distance to the screen width.

**TRC (Throw ratio correction)**

A special number used in calculating throw distances and throw ratios when the image does not fill the width of the DMD™. TRC is the ratio of the DMD™ aspect ratio to the image source aspect ratio:  $TRC = \text{DMD}^{\text{TM}} \text{ aspect ratio} / \text{Source aspect ratio}$  TRC is only used in calculations if it is greater than 1.

**U**

---

**UXGA**

A display resolution of 1600 x 1200 pixels with a 4:3 screen aspect ratio. (Stands for Ultra Extended Graphics Array.)

**V**

---

**Vertical Scan Rate**

The rate at which the frames of the incoming signal are refreshed. The rate is set by the vertical synchronization from the source and measured in Hertz.

**Vignetting**

Optical cropping of the image caused by the components in the projection lens. This can happen if too much offset is applied when positioning the image using the lens mount.

**Vista**

An aspect ratio of 1.66:1.

**Notes**

**W**

---

**WUXGA**

A display resolution of 1920 x 1200 pixels with a 16:10 screen aspect ratio. (Stands for Widescreen Ultra Extended Graphics Array.)

**Y**

---

**Y**

This is the luminance input (brightness) from a Component Video signal.

**YUV**

Color difference signals used with 'Y' for analog Component Video inputs. They provide information about the signal color. Not to be confused with Cr, Cb.

**Z**

---

**ZScreen**

A special kind of light modulator which polarizes the projected image for 3D viewing. It normally requires that images are projected onto a silver screen. The ZScreen is placed between the projector lens and screen. It changes the polarization of the projected light and switches between left- and right-handed circularly polarized light at the field rate.

**Notes**

# DIGITAL PROJECTION

A brand of  DELTA

## Contact Information:

### Europe

Digital Projection Limited  
Unit 3 Aniseed Park, Oldham  
Broadway Business Park,  
Oldham, England, OL9 9XA  
*Registered in England No.*  
*03287264*  
*Registered Office: As Above*  
Tel: (+44) 161 947 3300  
enquiries@digitalprojection.co.uk  
service@digitalprojection.co.uk  
www.digitalprojection.co.uk

### North America

Digital Projection Inc.  
55 Chastain Road, Suite 115,  
Kennesaw, GA 30144, USA  
Tel: (+1) 770 420 1350  
Fax: (+1) 770 420 1360  
contact@digitalprojection.com  
www.digitalprojection.com

### China

Digital Projection China  
中国北京市朝阳区芍药居北  
里101号世奥国际中心A座2301  
室(100029)  
Rm A2301, ShaoYaoJu 101 North  
Lane, Shi Ao International Center,  
Chaoyang District, Beijing 100029,  
PR CHINA  
Tel: (+86) 10 84888566  
Fax: (+86) 10 84888566-805  
techsupport@dp-china.com.cn  
www.dp-china.com.cn

### Japan

Digital Projection Japan  
〒105-0012 東京都港区芝大門  
2-1-14  
2-1-14 Shibadaimon, Minato-ku,  
Tokyo, Japan 105-0012  
japan@digitalprojection.co.uk  
www.digitalprojection.com/jp

### Taiwan

Digital Projection Taiwan  
186 Ruey Kuang Rd, Neihu  
District, Taipei, 114 Taiwan  
Tel: +886-8797-2088 x8854  
Taiwan@digitalprojection.co.uk

### Korea

Digital Projection Korea  
1511, Byucksan Digital Valley 6-  
cha, Gasan-dong, Geumcheon-  
gu, Seoul, Korea  
Tel: (+82) 2 515 5303 #1417  
Korea@digitalprojection.co.uk

### India

Digital Projection India  
Plot-43, Sector-35, HSIIDC,  
Gurgaon Haryana -122001  
Tel: +91-124-4874900#4275  
india@digitalprojection.co.uk