



Satellite Insight 8K 60

Digital Video Projector

INSTALLATION & QUICK START GUIDE, CONNECTION GUIDE
ON SCREEN DISPLAY (OSD) AND TOUCHSCREEN OPERATING GUIDES, REFERENCE GUIDE



A brand of  DELTA

Introduction

Congratulations on your purchase of this Digital Projection product. The Satellite Insight 8K 60 has the following key features:

- Satellite Modular Laser System
- Offers separation of Head from the light source for reduced size, weight and noise compared to a conventional projector.
- RGB laser illuminated
- Supports a combination of Modular Light Source modules including MLS 10000, MLS 20000 and MLS 30000.
- Satellite Link Cable enables light source MLS modules to be remote
- Wide color gamut very close to REC2020
- DisplayPort and HDMI Inputs
- Control via LAN
- Motorised and memorized lens mount with shift, zoom and focus using compatible lenses.
- 3D multiview for collaborative and interactive 3D

A serial number is located on the side of each Satellite module. Please record it here for future reference:

Follow the instructions in this manual carefully to ensure safe and long-lasting use of the projection system. Do not attempt to power the system on or operate the projector until the system has been safely installed. Please refer to the Installation and Quick Start Guide later in this manual for full installation details.

Notes



This product is a Laser Risk Group 3 product.

About this document

Symbols used in this document

Many pages in this document have a dedicated area for notes. The information in that area is accompanied by the following symbols:



LASER WARNING: this symbol indicates that there is a potential hazard of eye exposure to laser radiation unless the instructions are closely followed.



LIGHT HAZARD WARNING: this symbol indicates that there is a danger of exposure to intensive light that may result in personal injury unless the instructions are closely followed.



ELECTRICAL WARNING: this symbol indicates that there is a danger of electrical shock unless the instructions are closely followed.



WARNING: this symbol indicates that there is a danger of physical injury to yourself and/or damage to the equipment unless the instructions are closely followed.



NOTE: this symbol indicates that there is some important information that you should read.

Product revision

Because we at Digital Projection continually strive to improve our products, we may change specifications and designs, and add new features without prior notice.

Additional Documentation

Updates to this manual may be available online.

Please use the QR code (also located on the satellite projector head, modular light source and satellite control module) to access the latest Satellite system user guides and other documentation via the Digital Projection website.

Or visit the Digital Projection website to download the latest user guide and other documentation. www.digitalprojection.co.uk/digital-products/manuals/satellite/



Legal notice

Trademarks and trade names mentioned in this document remain the property of their respective owners. Digital Projection disclaims any proprietary interest in trademarks and trade names other than its own.

Copyright © 2024 Digital Projection Ltd. All rights reserved.

Third Party Credits

DMD™, Digital Micromirror Device™ and DLP™ are trademarks of Texas Instruments Inc.

Art-Net™ Designed by and Copyright Artistic License Holdings Ltd.

etherCON™ Designed by and Copyright Neutrik AG.

Notes

Electrical and Physical Specifications

Notes

Satellite Head

Mains Voltage	100-240 VAC 50/60Hz single phase		
Current	2.4 A at 100 VAC 1.2 A at 240 VAC		
Operating Temperature	0°C to 35°C (32°F to 95°F)		
Storage Temperature	-10°C to 50°C (14°F to 122°F)		
Operating Humidity	20% to 80% non-condensing		
Dimensions	W 430 mm (16.9 in), H 470 mm (18.5 in), D 450 mm (17.7 in)		
Weight	46 kg		
Power Consumption	at 100 VAC: typical 250 W at 240 VAC: typical 250 W		
Thermal Dissipation	at 100 VAC:	1200 BTU/hr at 10,000 Lumens	
		1540 BTU/hr at 20,000 Lumens	
		1880 BTU/hr at 30,000 Lumens	
		2220 BTU/hr at 40,000 Lumens	
	at 240 VAC:	1200 BTU/hr at 10,000 Lumens	
		1540 BTU/hr at 20,000 Lumens	
		1880 BTU/hr at 30,000 Lumens	
		2220 BTU/hr at 40,000 Lumens	
Fan Noise	< 40 dBA		

Modular Light Source

Multiple MLS are available for this system.

MLS 10000

Mains Voltage	100-240 VAC 50/60Hz single phase		
Current	10.1 A at 100 VAC 4.9 A at 240 VAC		
Operating Temperature	0°C to 40°C (32°F to 104°F)		
Storage Temperature	-10°C to 50°C (14°F to 122°F)		
Operating Humidity	20% to 80% non-condensing		
Dimensions	19" 3U rack unit - 483mm (w) x 133mm (h) x 500mm (d)		
Weight	16.5 kg		
Power Consumption	at 100 VAC: typical 910 W, max 1005 W at 240 VAC: typical 875 W, max 965 W		
Thermal Dissipation	at 100 VAC: typical 2625 BTU/hr, max 2950 BTU/hr at 240 VAC: typical 2500 BTU/hr, max 2810 BTU/hr		
Fan Noise	< 43 dBA		
Fuse in Fuse Holder	marking T15AH/250 VAC, or F15AH/250 VAC		

MLS 20000

Mains Voltage	100-240 VAC 50/60Hz single phase
Current	5.5 A at 100 VAC 10.5 A at 240 VAC
Operating Temperature	0°C to 40°C (32°F to 104°F)
Storage Temperature	-20°C to 60°C (-4°F to 140°F)
Operating Humidity	20% to 80% non-condensing
Dimensions	19" 4U rack unit - 483mm (w) x 178mm (h) x 725mm (d)
Weight	28 kg
Power Consumption	at 100 VAC: typical 438 W, max 482 W at 240 VAC: typical 1633 W, max 1983 W
Thermal Dissipation	at 100 VAC: typical 1495 BTU/hr, max 1645 BTU/hr at 240 VAC: typical 5572 BTU/hr, max 6128 BTU/hr
Fan Noise	< 56 dB (A)

MLS 30000

Mains Voltage	100-240 VAC 50/60Hz single phase
Current	6.5 A at 100 VAC 14.5 A at 240 VAC
Operating Temperature	0°C to 40°C (32°F to 104°F)
Storage Temperature	-20°C to 60°C (-4°F to 140°F)
Operating Humidity	20% to 80% non-condensing
Dimensions	19" 4U rack unit - 483mm (w) x 178mm (h) x 725mm (d)
Weight	29 kg
Power Consumption	at 100 VAC: typical 559 W, max 615 W at 240 VAC: typical 2488 W, max 2834 W
Thermal Dissipation	at 100 VAC: typical 1907 BTU/hr, max 2098 BTU/hr at 240 VAC: typical 8489 BTU/hr, max 9339 BTU/hr
Fan Noise	< 60 dB (A)

Notes

Satellite Control Module

Mains Voltage 100-240 VAC 50/60Hz single phase
 Current 1.0 A at 100 VAC
 0.5 A at 240 VAC
 Operating Temperature 0°C to 40°C (32°F to 104°F)
 Storage Temperature -10°C to 50°C (14°F to 122°F)
 Operating Humidity 20% to 80% non-condensing
 Dimensions 19" 4U rack unit - 483mm (w) x173mm (h) x 400mm (d)
 Weight 10 kg
 Power Consumption at 100 VAC: typical 100 W
 at 240 VAC: typical 100 W
 Thermal Dissipation at 100 VAC: typical 345 BTU/hr
 at 240 VAC: typical 345 BTU/hr
 Fan Noise < 30 dBA
 Fuse in Fuse Holder

Satellite Link Cable

Operating Temperature 0°C to 40°C (32 F to 104 F)
 Storage Temperature -10°C to 50°C (14 F to 122 F)
 Operating Humidity 20% to 80% non-condensing

 Specifications are subject to change without notice.

Laser Parameters

	MLS 10000	MLS 20000	MLS 30000
Wavelength (Red)	632-641 nm		
Wavelength (Blue)	459-471 nm		
Wavelength (Green)	519-531 nm		
Mode of operation	CW		
Total internal power	192 W	448 W	601 W

Light Output

The light output for your Satellite system is the sum total of lumens produced by the Modular Light Sources (MLS) installed:

MLS	Light output (klm)
MLS 10000	10 klm
MLS 20000	20 klm
MLS 30000	30 klm

Notes

 The maximum light output permitted for this Satellite Head is 36,000 klm.

For example; a system with one MLS 10000 will produce a total light output of 10 klm. A system with one MLS 10000 and one MLS 20000 will produce a total light output of 30 klm:

The light output at each Satellite head is the total light output divided by the number of Satellite heads in the system:

Total Light Output (klm)	Number of Satellite Heads	Light Output (klm) at each Satellite Head
10 klm	1	10 klm
	2	5 klm
	3	3.3 klm
	4	2.5 klm
20 klm	1	20 klm
	2	10 klm
30 klm	1	30 klm
	2	15 klm
40 klm	1	40 klm

For example; a system with one MLS 10000 and 2 Satellite heads will produce a total light output of 10 klm, but 5 klm at each Satellite Head. A system with two MLS 10000 and 1 Satellite head will produce a total light output of 20 klm at the Satellite Head.

Use the light output at the Satellite Head to determine the hazard distance when installing the Satellite Head. See Risk Group 3 Laser Hazard Installation Precautions on page 36.

Laser Power

The laser power for this projector is related to the fitted lens and the light output at the Satellite Heads:

Light output (klm) at each Satellite Head	Maximum Laser Power at Lens (mW)			
	0.93 : 1 fixed	1.13 - 1.72 : 1 zoom	1.65 : 2.60 : 1 zoom	2.53 - 4.98 : 1 zoom without Hood
2.5 klm	41	139	376	302
3.3 klm	54	186	502	402
5 klm	82	279	753	603
10 klm	163	557	1505	1206
15 klm	245	836	2258	1810
20 klm	326	1114	3010	2412
30 klm	489	1617	4515	3618
40 klm	652	2228	6020	4824

Notes

Compliance with International Standards



RF Interference

FCC

The Federal Communications Commission does not allow any modifications or changes to the unit EXCEPT those specified by Digital Projection in this manual. Failure to comply with this government regulation could void your right to operate this equipment.

This equipment has been tested and found to comply with the limits for a Class A digital device, pursuant with Part 15 of the FCC Rules. These limits are designed to provide reasonable protection against harmful interference when the equipment is operated in a commercial environment. This equipment generates, uses, and can radiate radio frequency energy and, if not installed and used in accordance with the instruction manual, may cause harmful interference to radio communications. Operation of this equipment in a residential area may cause harmful interference, in which case the user will be responsible for correcting any interference.

Noise

GSGV Acoustic Noise Information Ordinance

The sound pressure level for the Satellite Laser Head is less than 40 dB (A) according to ISO 3744 or ISO 7779.

The sound pressure level for the Modular Light Source (MLS 10000) is less than 43 dB (A) according to ISO 3744 or ISO 7779.

The sound pressure level for the Modular Light Source (MLS 20000) is less than 54 dB (A) dB (A) according to ISO 3744 or ISO 7779.

The sound pressure level for the Modular Light Source (MLS 30000) is less than 58 dB (A) dB (A) according to ISO 3744 or ISO 7779.

The sound pressure level for the Satellite Control Module is less than 30 dB (A) according to ISO 3744 or ISO 7779.

European Waste Electrical and Electronic Equipment (WEEE) Directive



Digital Projection Ltd is fully committed to minimizing Waste Electrical and Electronic Equipment. Our products are designed with reuse, recycling and recovery of all components in mind. To this end, at end of life, your projector may be returned to Digital Projection Ltd or its agent so that the environmental impact can be minimized.

Notes

Contents

Notes

Introduction **2**

About this document **3**

Symbols used in this document 3

Product revision 3

Additional Documentation 3

Legal notice 3

Third Party Credits 3

Electrical and Physical Specifications **4**

Satellite Head 4

Modular Light Source 4

Satellite Control Module 6

Satellite Link Cable 6

Laser Parameters 6

Light Output 6

Laser Power 7

Compliance with International Standards **8**

RF Interference 8

Noise 8

European Waste Electrical and Electronic Equipment (WEEE) Directive 8

Contents **9**

Installation & Quick Start Guide **13**

General Precautions **14**

What's in the box? **16**

Satellite Head 16

Modular Light Source - MLS10000 (Shipped Separately) 17

Modular Light Source - MLS20000, MLS30000 (Shipped Separately) 17

Satellite Control Module (Shipped Separately) 18

Satellite Link Cable (Shipped Separately) 19

Module Overviews **20**

Satellite Head 20

Modular Light Source 21

MLS 10000 21

MLS 20000 / MLS 30000 22

Satellite Control Module 23

Location of Laser Aperture 24

Interlock Switches 25

Satellite Head 25

Modular Light Source - MLS10000 26

Modular Light Source - MLS 20000/MLS 30000 26

Satellite Control Module 27

Satellite Link Cable 27

Installation Precautions **28**

Risk Group 3 precautions: 28

For Installations within the United States: 28

Risk Group 3: 28

Satellite Head 29

Modular Light Source and Satellite Control Module 32

Rack Mounts 32

Free Standing 32

Satellite Link Cable 33

Handling Precautions 34

Laser Safety Precautions **35**

Laser Risk Group 3 Precautions 35

Risk Group 3 Laser Hazard Installation Precautions **36**

Laser Risk Group 3 Installation Precautions 36

Light Hazard Warning 36

Light Hazard Distance and Hazard Zone 37

Restriction Zone 38

Fitting a lens **39**

Inserting a new lens 39

Removing the lens 40

Fitting a lens hood 41

Positioning the screen and Satellite Head **44**

Mounting the rack mount modules **45**

MLS 10000 45

MLS 20000/MLS 30000 46

SCM 46

Connecting the Satellite Link Cable **47**

Connecting the Signal and LAN cables **50**

Single Satellite Head and Modular Light Source - 1:1 System 53

Multiple Modular Light Sources - n:1 System 54

Multiple Satellite Projector Heads - 1:n System 56

Power Supply 58

 AC Power Precautions 58

 Connecting the power supply 59

Basic Operating Instructions 61

 Switching the system on 61

 Switching the projector off 61

 Emergency off 61

 Interlock reset 62

 Setting the Number of MLS 62

 Selecting an input signal 62

 Selecting a test pattern 62

 Adjusting the lens 63

 Adjusting the image 63

 Orientation 63

 Picture 63

Laser color calibration 64

Operating the system 65

 Satellite Head Control panel 65

 Remote control 66

 Infrared reception 70

 Module indicators 71

 Satellite Head 71

 Modular Light Source 72

 MLS 10000 72

 MLS 20000 / MLS 30000 72

 Satellite Control Module 72

Connection Guide 73

Signal inputs 74

 Digital inputs and outputs 74

 EDID on the DisplayPort and HDMI inputs 75

 Using DisplayPort / HDMI switchers with the Satellite Head 75

 8K alternate pixel packing 76

3D connections 77

 3D frame packing, side-by-side and top and bottom formats 78

 Frame sequential 78

 Dual Pipe (Left/Right) 78

 Dual Pipe (East/West) 78

 3D Sync 78

 3D Multiview 79

Control connections 80

 LAN connection examples 81

Indicators on the connection panel 82

On Screen Display (OSD) Operating Guide 83

Introduction to the OSD 84

 Opening the Menu 84

 Opening a submenu 84

 Exiting menus and closing the OSD 85

 Inside a menu 86

 Accessing sub menus 86

 Executing commands 87

 Editing projector settings 87

 Using a slider to set a value 88

 Editing numeric values 88

Using the projector 89

 Main Menu 89

 Input 90

 Resync 91

 Lens 92

 Lens Calibrate 93

 Lens Presets 93

 Lens Presets Store 94

 Image 95

 Geometry 96

 Colour 97

 3D 98

 3D types 99

 Some 3D settings explained 101

 Dark Time 101

 OSD 102

 System 102

 Information 103

 Network 103

System	104
Hardware	104
Software	105
Video	105
Service	106
Satellite Head Touchscreen Operating Guide	107
Introduction to the Satellite Head Touchscreen	108
Using the menus	108
Main Menu	109
Input	109
Set Input	110
Set Multi Input	110
Resync	111
Test Patterns	111
More Test Patterns	111
Lens	112
Lens Nudge	112
Lens Shift	112
Lens Focus	113
Lens Zoom	113
Lens Advanced	114
Lens Calibrate	114
Lens Presets	115
Lens Presets Store	115
Image	116
Geometry	116
Scaler Points	117
Orientation	117
Colour	118
Colour Lift	118
Colour Gain	118
Advanced Colour	119
Colour Space	119
Color Sampling	119
Colour Preset	120
ColourMax	120
Target Colour	121
Measured Colour	121
Gamut Chart	122
3D	122

3D Dark Time	123
Set Dark Time	123
3D Format	123
Set 3D Format	124
3D Sync	124
3D Sync In	124
Sync In Polarity	125
3D Sync Out	125
Sync Out Polarity	125
3D Advanced	126
Set Dominance	126
Set Multiplier	126
System	127
Laser	127
Standby	127
Remote Control	128
OSD	128
Advanced	128
Information	129
Network	129
System	129
Hardware	130
Software	130
Video	130
Service	131
Interlocks	131
MLS 10000 Touchscreen Operating Guide	133
Introduction to the MLS 10000 Touchscreen	134
Using the menus	134
Main Menu	135
Laser	135
Setup	136
OSD Settings	136
Network	136
Information	137
System Status	137
Thermal Status	138
Factory Reset	138
MLS 20000 / MLS 30000 LCM Screen Operating Guide	139

Notes

Introduction to the MLS 20000 / MLS 30000 LCM Screen **140**

LCM Pages 140

System Status 140

System Information 141

Network Information 141

Thermal Information 141

Error Page 141

SCM Touchscreen Operating Guide **143**

Introduction to the SCM Touchscreen **144**

Using the menus **145**

System Configuration 145

Main Menu 145

Laser Power 146

Interlocks 146

Network 146

Information 147

Network Information 147

Software Information 147

System Information 148

Hardware Information 148

Service Information 149

Component menu 149

Reference Guide **151**

Appendix A: Product labels **152**

Satellite Head 152

Label Locations 154

Modular Light Source 155

MLS 10000 Label Locations 157

MLS 20000/MLS 30000 Label Locations 158

Satellite Control Module 159

Label Locations 160

Satellite Link Cable 161

Label Locations 161

Lens Hood 162

Lens Hood 162

Appendix B: Choosing a lens **163**

Basic calculation 164

Basic calculation example 165

Full lens calculation 166

Introducing TRC 166

Calculating TRC 167

TRC table 167

Calculating the throw ratio with TRC 167

Full lens calculation example 168

Appendix C: Positioning the image **169**

Appendix D: Supported signal input modes **170**

2D formats 170

3D formats 173

Appendix E: How 8K is Processed **174**

Appendix F: Wiring details **175**

Signal inputs and outputs 175

HDMI 175

DisplayPort 176

Control connections 176

LAN 176

RS232 177

Trigger 177

Appendix G: Cleaning the SLC **178**

Appendix H: Served web pages **179**

Appendix I: Glossary of terms **181**

Notes



Satellite Insight 8K 60

Digital Video Projector

INSTALLATION & QUICK START GUIDE



A brand of  DELTA

General Precautions

Notes

 **Warning! Death or Serious Injury could occur if the following precautions are ignored**

 **Eye Hazard! Do not look directly into the lens when the light source is on. The high brightness can cause permanent eye damage**

 **Fire Hazard! Keep any combustible material away from hot surfaces and the projected beam. Ensure cables do not contact hot surfaces**

 **Shock Hazard! Use only authorized components, tools, accessories and replacement parts specified by the manufacturer**

 **Trip Hazard! Locate cables where they cannot be pulled, tripped over or damaged by persons or objects**
Operate the product in the specified operating environment and conditions

Product should be powered off and disconnected from the mains before any service or maintenance operation

Keep body parts, hair, clothing and jewelry away from moving parts in the product.

Do not operate the product without a lens installed

Use a lens plug when installing or moving the product

 **The system is never to be operated if a component is defective or the covers are damaged.**

 **No maintenance allowed by end user.**
Do not open any of the modules. There are no user serviceable parts inside.

No service is allowed except by authorized personnel.

 **Service personnel should use effective laser safety goggles during service operations.**

 **Use only the power cable provided.**

 **Ensure that the power outlet includes a Ground connection, as this equipment **MUST** be earthed.**

 **Take care to prevent small objects such as paper or wire from falling into the Satellite Head , MLS or SCM. If this does happen, switch off immediately, and have the objects removed by authorized service personnel.**

 **Do not expose the Satellite Head , MLS and SCM to rain or moisture, and do not place any liquids on top of the projector.**
Unplug before cleaning, and use a damp, not wet, cloth.

Do not touch the power plug with wet hands.

Do not touch the power plug during a thunder storm.

Handle the power cable carefully and avoid sharp bends. Do not use a damaged power cable.



Do not touch the ventilation outlets, as they will become hot in use.

Do not cover or obstruct the ventilation outlets or inlets.

Do not cover the lens whilst the system is switched on. This could cause a fire.

Always allow the Satellite Head , MLS and SCM to cool for 5 minutes before disconnecting the power or moving the projector.

Never use strong detergents or solvents such as alcohol or thinners to clean the projector and lens.

Notes

What's in the box?

Satellite Head

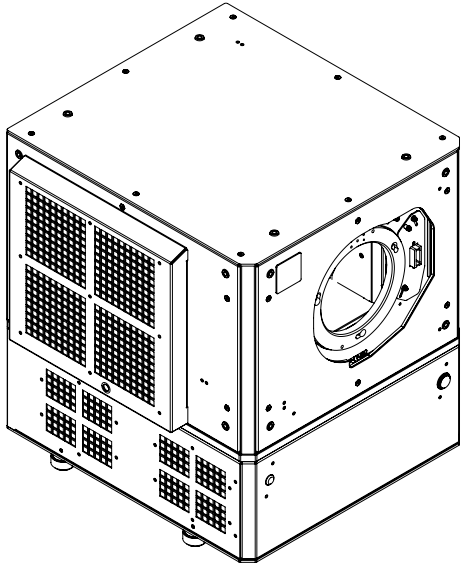

Satellite Head

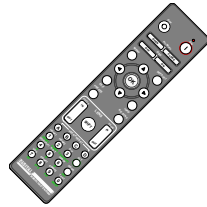

Remote Control

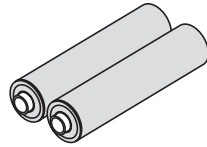

Batteries (2xAAA)

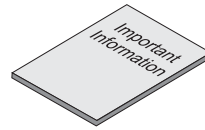

Important Information Book

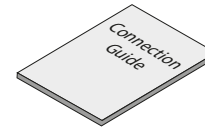

Connection Guide

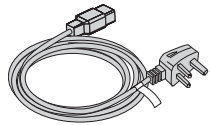

Power Cable, UK

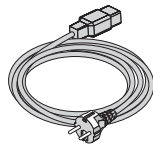

Power Cable, Europe

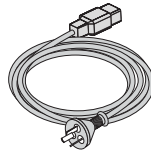

Power Cable, China

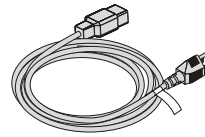



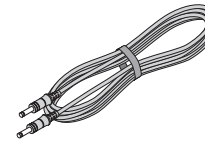



NEMA 5-15P - C19 Power Cable, North America



Remote Control Cable

Notes

-  The MLS, SCM and SLC are shipped separately.
-  The appropriate MLS modules are supplied for your system.
-  The projector is shipped without a lens.
-  Make sure your box contains everything listed. If any pieces are missing, contact your dealer.
-  Only one remote is supplied with the projector.
-  Only the appropriate power cables for destination territory are supplied.
-  Save and store the original box and packing materials, in case you ever need to ship your projector.

Modular Light Source - MLS10000 (Shipped Separately)

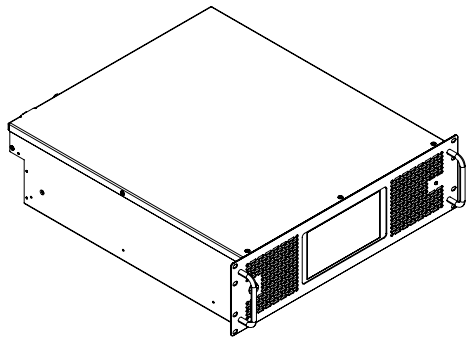

Modular Light Source (MLS 10000)

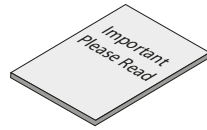

Important Please Read Booklet

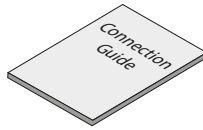

Connection Guide



Laser Key (x2)



LAN Cable

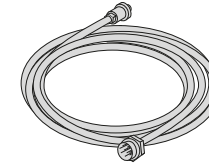

SCM - MLS Signal Cable

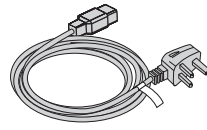

Power Cable, UK

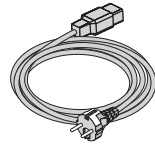

Power Cable, Europe

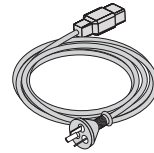

Power Cable, China

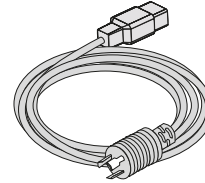

NEMA L5-20P - C19 Power Cable, North America

Modular Light Source - MLS20000, MLS30000 (Shipped Separately)

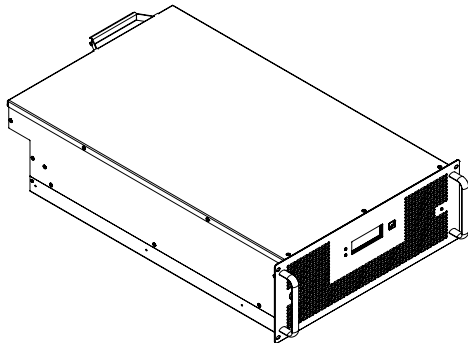

Modular Light Source (MLS 20000, MLS 30000)



Important Please Read Booklet

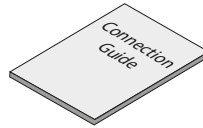

Connection Guide



Laser Key (x2)



LAN Cable

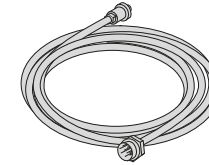

SCM - MLS Signal Cable

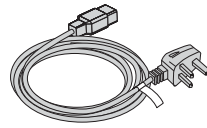

Power Cable, UK

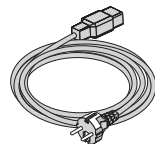

Power Cable, Europe

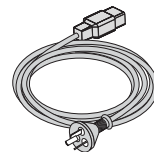

Power Cable, China

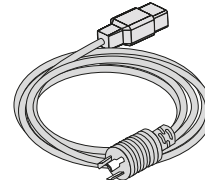

NEMA L5-20P - C19 Power Cable, North America

Notes

Satellite Control Module (Shipped Separately)

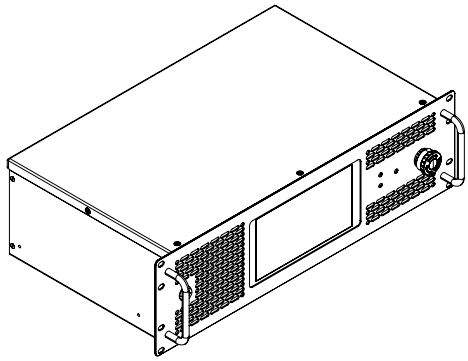

Satellite Control Module (SCM)

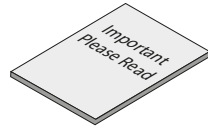

Important Please Read Booklet

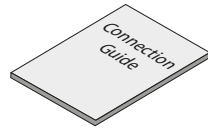

Connection Guide



Laser Key (x2)

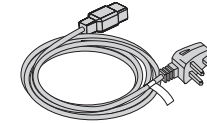

Power Cable, UK

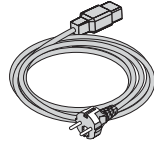

Power Cable, Europe



Power Cable, China

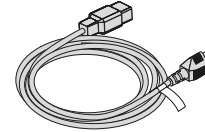

NEMA 5-15P - C19 Power Cable, North America

Notes

Satellite Link Cable (Shipped Separately)

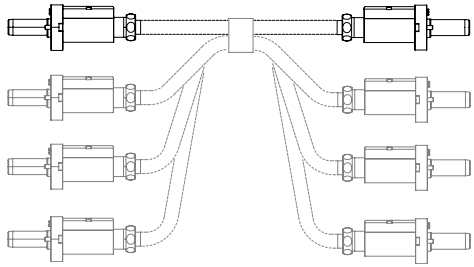

Satellite Link Cable (SLC)

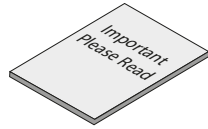

Important Please Read Booklet

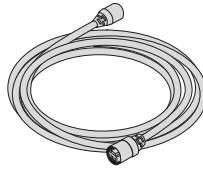

LAN Cable

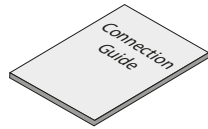



Connection Guide





Hex Driver

Notes

 The SLC connects Modular Light Sources (MLS) to Satellite Heads. The SLC includes a built in junction box with additional MLS or Satellite Head connections when there are multiple MLS or Satellite Heads. Only the appropriate SLC for your projector system is supplied.

 See Satellite Link Cable on page 33 for guidance regarding your installation.

 The appropriate number of LAN cables are included. One LAN cable is supplied per Satellite Head.

 **Handle the SLC with care. Do not drop or knock the SLC when removed from its packaging. The curvature of the SLC should never have a radius of less than 20 cm. Below this, the fiber inside the cable may be damaged.**

Module Overviews

Satellite Head

1. Air inlet
2. Lens mount
3. Front infrared window
4. Air inlet
5. Air inlet
6. Rear infrared window
7. SLC socket
8. Control panel
9. Air outlet
10. Air inlet
11. Air inlet
12. LAN socket
13. Connections panel
14. Mains socket

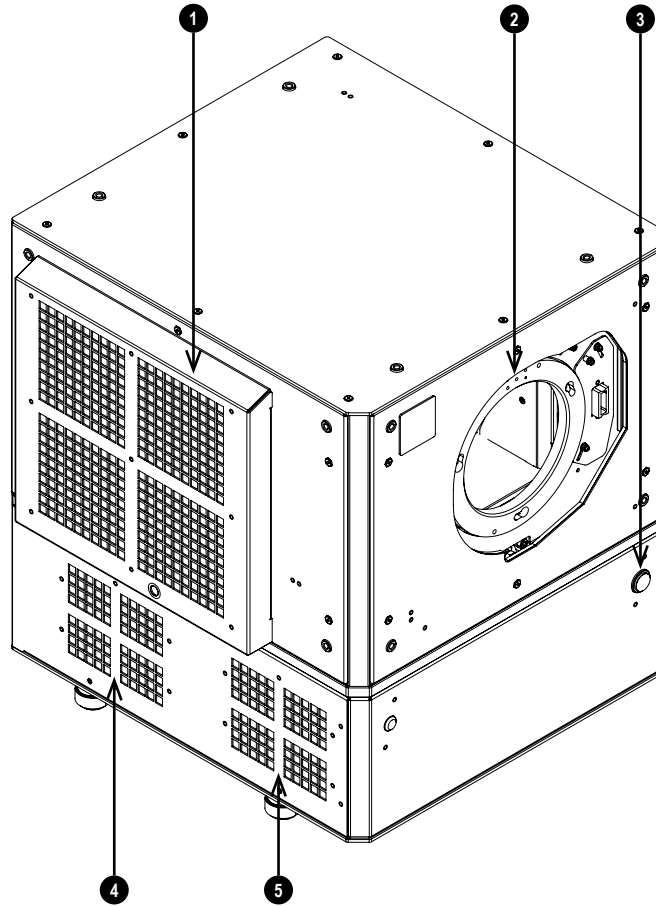

Satellite Head Front View

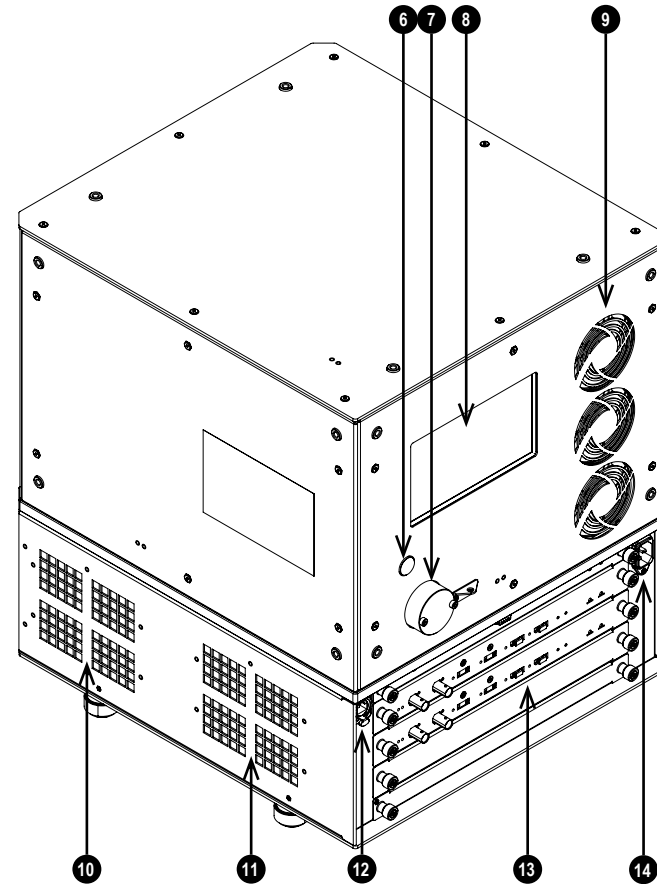

Satellite Head Rear View

Notes

See Product labels on page 152 for details about the labels that are located on the Satellite Head, MLS, SCM and SLC.

Modular Light Source

MLS 10000

1. Air inlet
2. Touch Screen Control Panel
3. Air inlet
4. Laser Activation Lock
5. Laser Indicator
6. Air outlet
7. Signal Cable socket
8. LAN socket
9. Mains socket
10. SLC socket

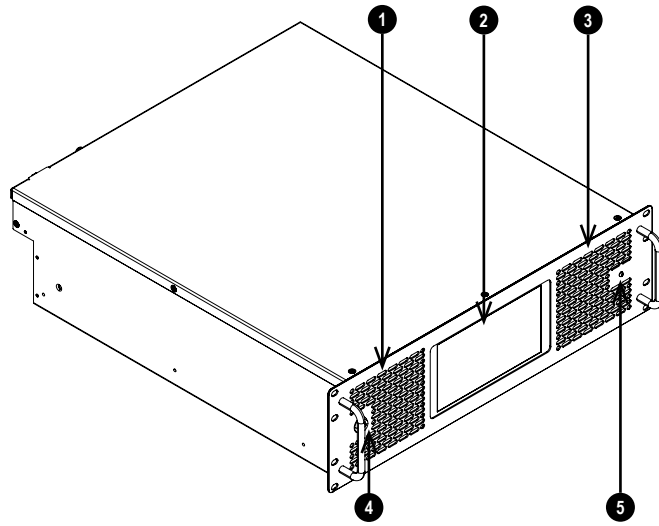

MLS Front View

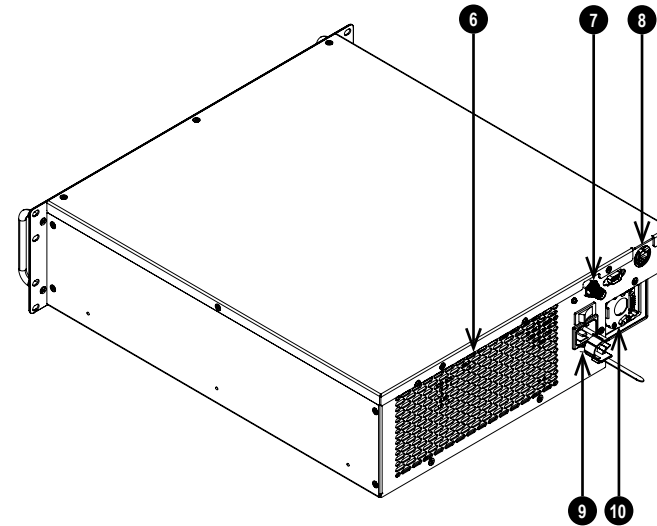

MLS Rear View

Notes

MLS 20000 / MLS 30000

1. LCM Panel
2. Laser Activation Lock
3. Air inlet
4. Laser Indicator
5. Air outlet
6. Mains socket
7. LAN socket
8. SLC socket
9. Signal Cable socket

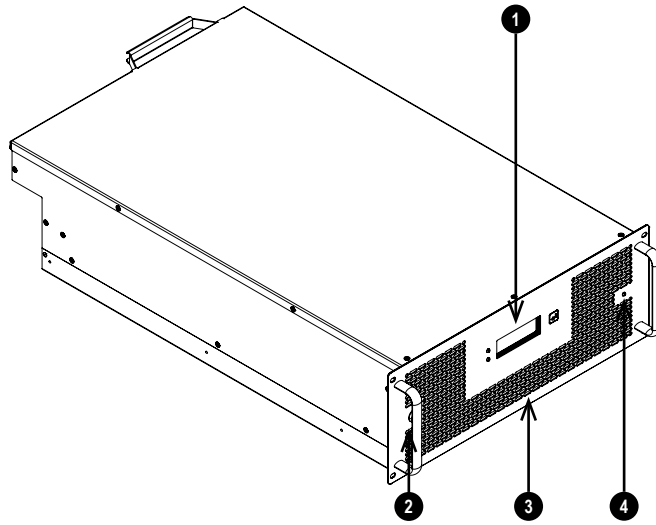

MLS Front View

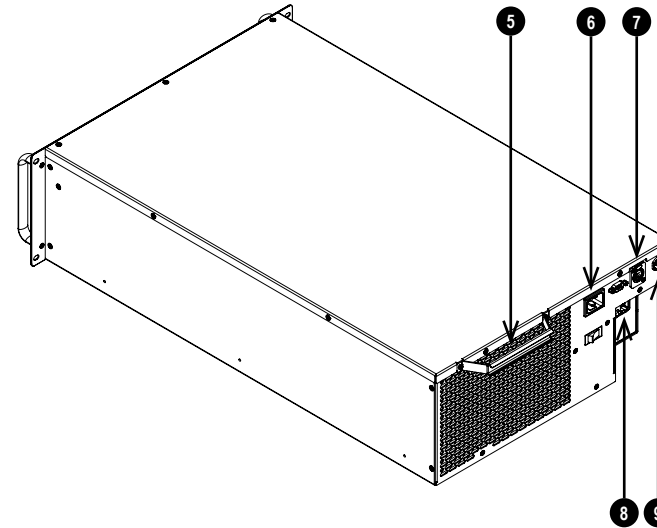

MLS Rear View

Notes

Satellite Control Module

1. Air inlet
2. Touch Screen Control Panel
3. Air inlet
4. Emergency Stop
5. Laser Activation Lock
6. SCM Indicators
7. Air inlet
8. Air outlet
9. Connections panel
10. Mains socket

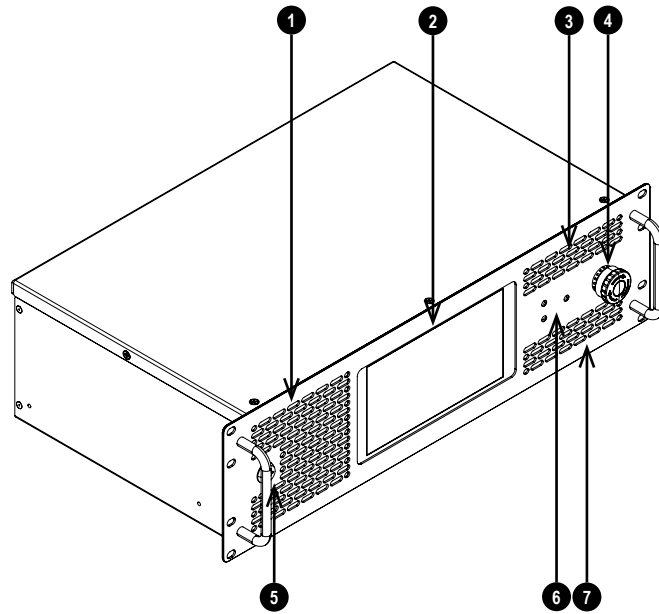

Front View

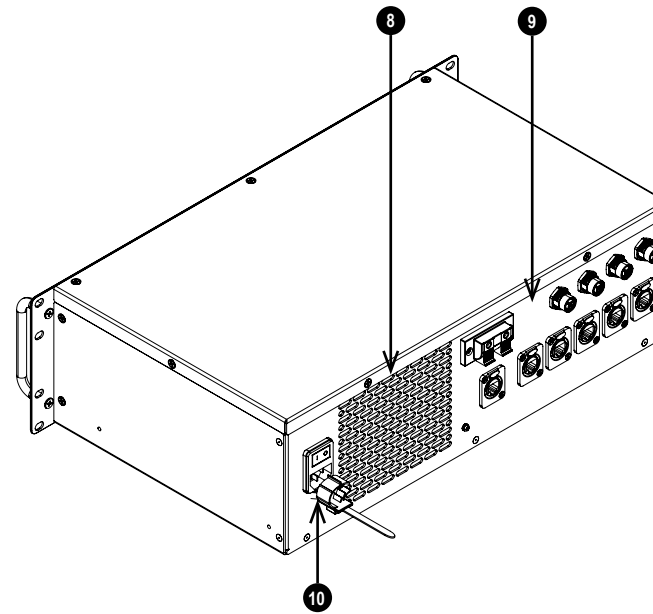

Rear View

Notes

Location of Laser Aperture

1. The laser aperture is located as indicated below.



Do not look directly at the light coming from the lens.

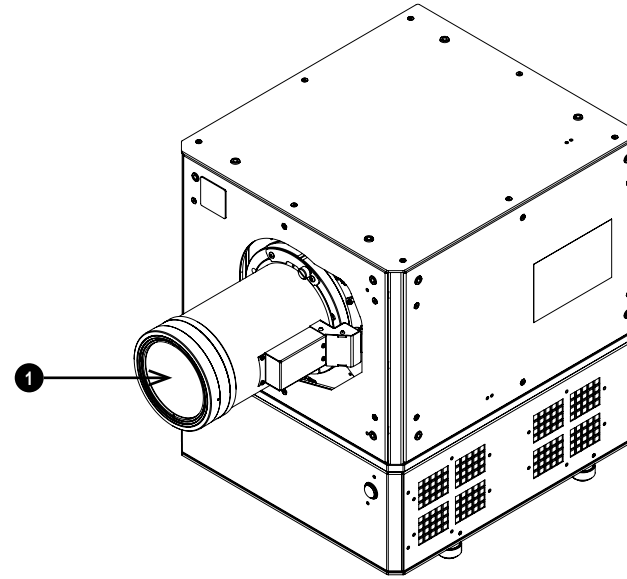

Notes

Interlock Switches

Interlock switches are installed. Any individual interlock switch will power-off the lasers when opened.

Satellite Head

1. Will be opened when the front cover is removed.
2. Will be opened when the projection lens is removed or misplaced.
3. Will be opened when the top cover is removed.
4. Will be opened when the left side cover is removed.
5. Will be opened when the rear cover is removed.
6. Will be opened when the Satellite Link Cable is removed or misplaced.
7. Will be opened when the bottom cover is removed.
8. Will be opened when the right side cover is removed.

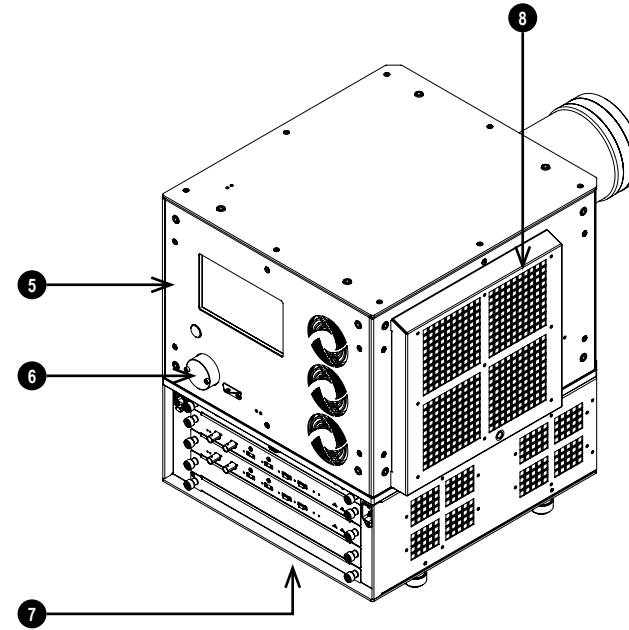
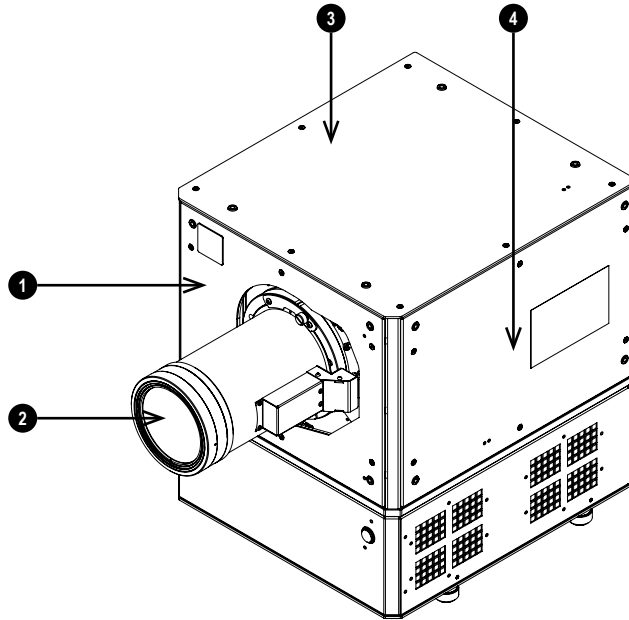

Notes

Modular Light Source - MLS10000

1. Will be opened when the MLS-SCM signal cable is removed or misplaced.
2. Will be opened when the Satellite Link Cable is removed or misplaced.
3. Will be opened when the cover is removed.

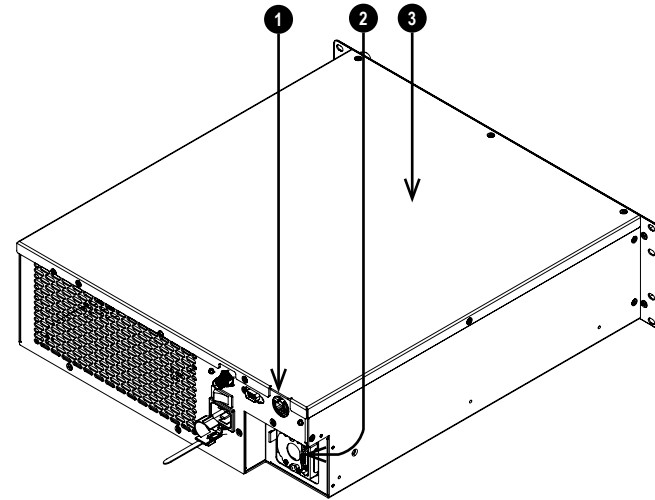

Modular Light Source - MLS 20000/MLS 30000

1. Will be opened when the MLS-SCM signal cable is removed or misplaced.
2. Will be opened when the Satellite Link Cable is removed or misplaced.
3. Will be opened when the cover is removed.

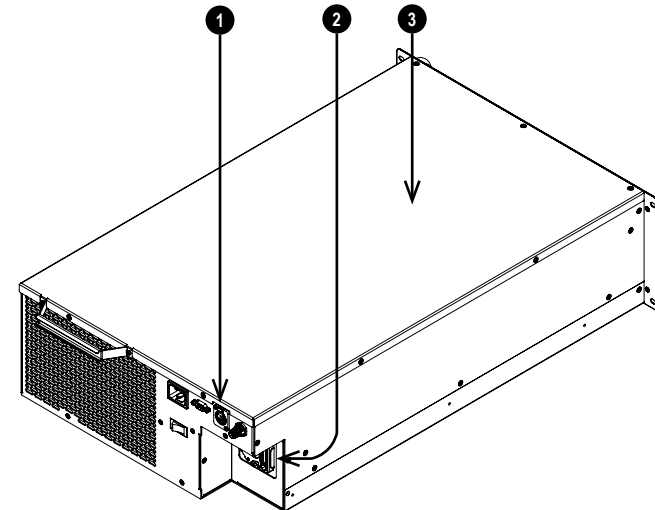

Notes

Satellite Control Module

1. External interlock. Use this to allow an external device, such as a door switch, to switch off the laser. The interlock is delivered with a wire link in place. If the link is removed the interlock will open and prevent the laser from turning on.
2. Will be opened when the MLS-SCM signal cable is removed or misplaced.

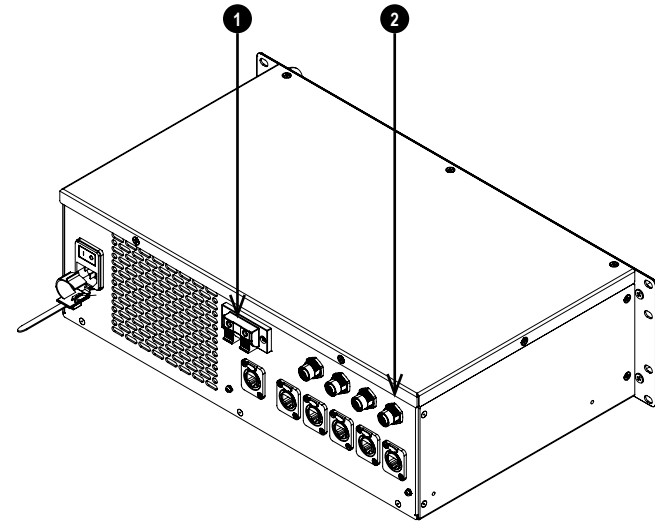

Notes

Satellite Link Cable

1. The cable contains a thermal sensor. Avoid direct sources of heat.
2. Will be opened when the Satellite Link Cable is removed or misplaced in the Satellite Head or MLS.

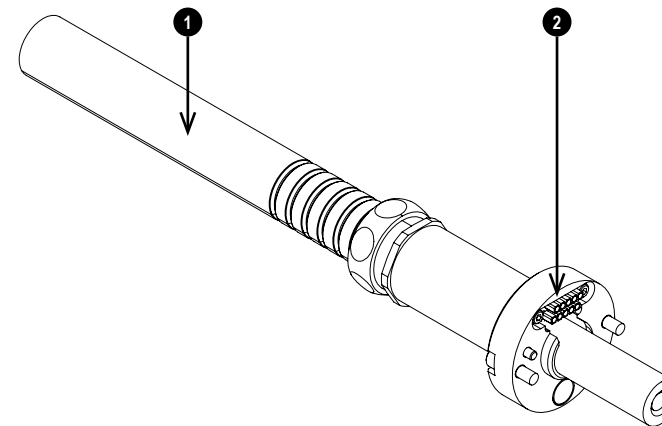

Handle the SLC with care. Do not drop or knock the SLC when removed from its packaging. The curvature of the SLC should never have a radius of less than 20 cm. Below this, the fiber inside the cable may be damaged.



Once the thermal sensor has exceeded its trip level, it cannot be reset. Do not exceed 100°C.

Installation Precautions

Notes



All installations should follow local building and electrical codes of practice

Components of the Satellite MLS are heavy. Use safe handling techniques when lifting.

Do not drop or knock the Satellite Head, Modular Light Source (MLS), Satellite Control Module (SCM) or Satellite Link Cable (SLC).

Use only the power cables, SLC cables and MLS signal cables provided.

The power cables, MLS signal cable, satellite link cable and signal input cable should be connected before the system is powered on.

During startup and operation, DO NOT insert or remove the SLC, MLS signal cable, signal input cable or the power cable to avoid damaging the system.

Risk Group 3 precautions:



Warning! This product is a Class 1, Risk Group 3 Laser Product.

The product should be installed and operated in accordance with the provisions of IEC 62471-5:2015 and the Important Information document and User Manual by instructed and skilled persons only (IEC 62368-1:2020).

Operators shall control access to the beam within the hazard distance or install the product at a height that will prevent exposure of the spectator's eyes within the hazard distance.

No direct exposure to the beam shall be permitted, RG3 IEC 62471-5:2015.

Do not place reflective objects in the projected beam

The hazard zone must be no lower than 3 meters above the floor and the horizontal clearance to the hazard zone must be a minimum of 2.5 meters. See See Risk Group 3 Laser Hazard Installation Precautions on page 36.

For Installations within the United States:

The following requirements must be in place for installations within the USA:



Certain US States have additional laser regulatory requirements.

Dealers and Distributors of Laser Illuminated Projectors, including installers, must comply with the record keeping requirements described in 21 CFR 1002.40.

Risk Group 3:



Any human access to the hazard zone must be restricted by barriers to enforce the no access zone

Permanent show installations containing RG3 laser illuminated projectors must meet the following conditions:

- Installed by Digital Projection or Digital Projection authorized and trained engineers
- Operated according to instructions provided by Digital Projection
- Ensure the projection system is securely mounted to prevent unintended movement of the projector

A copy of the FDA Variance Approval Letter must be with the operator or other responsible person

Temporary show installations containing RG3 laser illuminated projectors may be installed by Digital Projection, or sold or leased, only to valid laser light show variance holders for image projection applications. This requirement also applies to dealers and distributors of this equipment.

For temporary installations, the FDA variance holder must maintain complete records of all show itineraries with dates, locations, operator's name and contact information in a clear and concise way.

The Digital Projection Laser Projector Installation Checklist must be fully completed after installation and sent to Digital Projection. The user may retain a copy.

Satellite Head



Do not install the Satellite Head close to anything that might be affected by its operational heat, for instance, polystyrene ceiling tiles, curtains etc. Place the projector in a dry area away from sources of dust, moisture, steam, smoke, sunlight or heat.

Ensure that the intake vents do not recycle hot air from the exhaust vent.

When operating the Satellite Head in an enclosed space, ensure that the surrounding air temperature within the enclosure does not exceed operation temperature while the Satellite Head is running, and the air intake and exhaust vents are unobstructed.

All enclosures should pass a certified thermal evaluation to ensure that the Satellite Head does not recycle exhaust air, as this may cause the device to shutdown even if the enclosure temperature is with the acceptable operation temperature range.

Avoid installing at high temperature, insufficient cooling and heavy dust locations.

Avoid installing near an air conditioner duct or a subwoofer.

The Satellite Head should be installed as close to the power outlet as possible.

The power connection should be easily accessible, so that it can be disconnected in an emergency.



Please pay attention to Satellite Head installation with respect to other staging laser light equipment set-up. These systems can cause permanent damage to the imaging devices (DMD™) used in the Satellite Head. This damage is not covered by our warranty.

When using a Satellite Head in an environment with third party high power laser systems avoid direct laser beams pointing towards the projection lens. This may cause incident light to converge into the optical engine and cause damage to the imaging devices (DMD™).

Before installation, make sure that the surface, ceiling or rigging that is to support the Satellite Head is capable of supporting the combined weight of the Satellite Head, lens, SLC and cables.

Backup safety chains or wires should always be used with ceiling mount installations.

When installing a ceiling mount, make sure the weight limit is not exceeded and the Satellite Head is firmly secured.

Notes

The Satellite Head can be operated any position, as shown in the diagram:

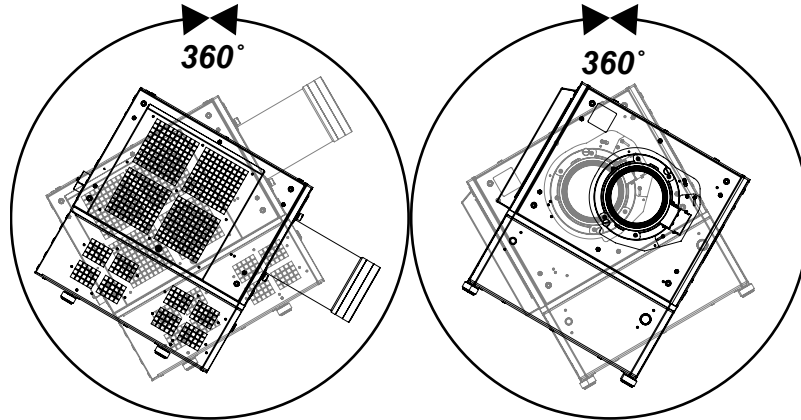

Tilt (Left) and Roll (Right)

Allow at least 50cm (19.7in) of space between the ventilation outlets and any wall, and 30cm (11.8in) on all other sides.

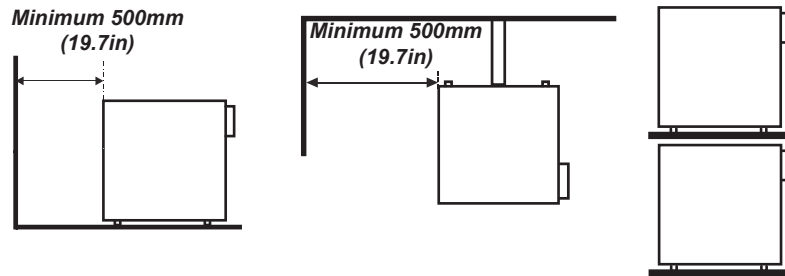

Example Positioning

When stacking the Satellite Head , the stack **MUST** be vertical, to ensure that the stresses are distributed to all four chassis corners.

Do not stack more than 2 Satellite Heads.

Notes

Make sure that there is a 3cm (1.2in) gap between Satellite Heads when stacked.

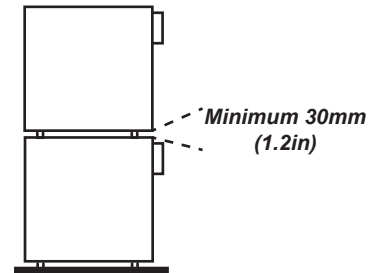

Example Stacking



Make sure the lens cap is removed from the lens before operating the Satellite MLS. Light energy levels have been known to cause damage to both the lens and projector optics. This damage is not covered by our warranty.

Make sure the lens cap is removed from the rear of the lens before it is inserted into the Satellite Head .

FDA regulations require that a lens hood is permanently fitted when using the 2.53 - 4.98 : 1 zoom lens with the Satellite Head in the United States of America. This lens will be supplied with the lens hood pre-fitted.

Connect the LAN cable only to a computer LAN connection. Other similar connectors may have a dangerously high voltage source.

The Satellite Head generates heat during use. The internal fans dissipate the heat of the Satellite Head when shutting down, which could continue for a certain period. After the projector enters STANDBY MODE, remove the power cord. DO NOT remove the power cord during shutdown as it may cause damage to the Satellite Head and may affect the service life of the Satellite Head .

Do not place heavy objects on top of the Satellite Head .

Notes

Modular Light Source and Satellite Control Module



The MLS and SCM are designed to be installed in a rack system. The MLS and SCM can also set up in a free standing installation. Rack installation is preferable.



The MLS must be mounted or placed horizontally during operation.



The laser colors must be calibrated after installation or after changing MLS within a system. See Laser color calibration on page 64 for guidance.

Rack Mounts



Do not install the rack containing the MLS and SCM close to anything that might be affected by its operational heat, for instance, curtains or other combustible materials etc.

Place the rack in a dry area away from sources of dust, moisture, steam, smoke, sunlight or heat.

Inside the rack, make sure there is a space between MLS and SCM modules.



Air vents are located at the front and rear of the modules. Make sure that the air intake and exhaust vents on the MLS and SCM are unobstructed and that the intake vent does not recycle hot air from the exhaust vent.

Make sure that the rack mount is ventilated and that any door or coverings include ventilation holes.

Make sure that the surrounding air temperature within the rack does not exceed operation temperature while the MLS and SCM are running. The rack mount should pass a certified thermal evaluation to ensure that the MLS and SCM do not recycle exhaust air, as this may cause the system to shutdown even if the temperature is within the acceptable operation temperature range.

Avoid installing at high temperature, insufficient cooling and heavy dust locations.

Avoid installing near an air conditioner duct or a subwoofer.

The rack mount should be installed as close to the power outlet as possible.

The EMERGENCY OFF button on the SCM should be easily accessible.

Free Standing



Do not install the MLS and SCM close to anything that might be affected by its operational heat, for instance, polystyrene ceiling tiles, curtains etc.



Place the MLS and SCM in a dry area away from sources of dust, moisture, steam, smoke, sunlight or heat.



Air vents are located at the front and rear of the modules. Make sure that the air intake and exhaust vents on the MLS and SCM are unobstructed and that the intake vent does not recycle hot air from the exhaust vent.

Notes

Allow at least 50cm (19.7in) of space between the ventilation outlets and any wall.

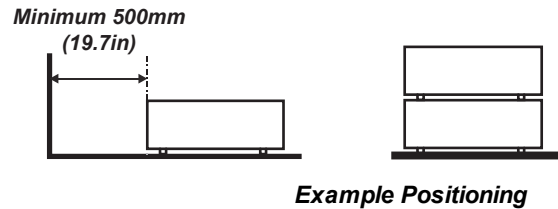

Notes



When operating the MLS and SCM in an enclosed space, ensure that the surrounding air temperature within the enclosure does not exceed operation temperature while the MLS and SCM are running. All enclosures should pass a certified thermal evaluation to make sure that the MLS and SCM do not recycle exhaust air, as this may cause the system to shutdown even if the enclosure temperature is within the acceptable operation temperature range.

Avoid installing at high temperature, insufficient cooling and heavy dust locations.

Avoid installing near an air conditioner duct or a subwoofer.

The MLS and SCM should be installed as close to the power outlet as possible.

The EMERGENCY OFF button on the SCM should be easily accessible.

Before installation, make sure that the surface is capable of supporting the weight of the MLS or SCM.

When installed, make sure the MLS is level with a maximum deviation of +/- 7 degrees.

When stacking MLS or SCM, the stack **MUST** be vertical, to ensure that the stresses are distributed to all four chassis corners.

Do not stack more than 3 MLS or SCM.

Make sure that there is a 3cm gap between MLS when stacked.

The MLS and SCM modules generate heat during use. The internal fans dissipate the heat of the MLS or SCM when shutting down, which could continue for a certain period. After the projector enters STANDBY MODE, remove the power cord. **DO NOT** remove the power cord during shutdown as it may cause damage to the MLS or SCM and may affect the service life.



Do not place heavy objects on top of the projector MLS or SCM.

Satellite Link Cable



Handle the SLC with care. Do not drop or knock the SLC when removed from its packaging. The curvature of the SLC should never have a radius of less than 20cm. Below this, the fiber inside the cable may be damaged.

When spooling cable in multiple loops, maintain a minimum diameter of 80cm and avoid twisting the cable.

The end caps on the Satellite Link Cable should remain in place until fitting.

When installed in trunking, the SLC should be hand laid along the entire length of trunking. Do not pull the cable through a conduit.

Use a cable protector at any location where the cable may be exposed to traffic.

Avoid installing the cable at locations where it may be exposed to high temperatures. The Satellite Link Cable contains a thermal sensor, avoid direct sources of heat. Do not exceed 100°C. If the thermal sensor exceeds its trip level it cannot be reset and the interlock circuit will remain open.

Make a basic visual inspection on the ends of the Satellite Link Cable to check for dust. Cleaning with cloth should be avoided and only an optical grade aerosol type duster should be used sparingly.

When removing the cable, it should be rolled up to avoid twisting the cable. Maintain a minimum diameter of 80cm when rolling the cable up.

Handling Precautions

The SLC must be handled with care. The SLC can be damaged if handled improperly. Follow the handling procedures shown in this document to prevent damage to the SLC assembly.

Digital Projection Ltd. will not guarantee or be held responsible for any damage caused when failing to follow these precautions:



Unroll the product from its packaging to avoid any twisting in the SLC.

Do not allow kinks or knots to develop in the SLC.

Do not bend the SLC tighter than a 20cm radius.

Hold the SLC connector when connecting or unplugging it from a device.

Never use the SLC to pick up or drag the device to which it is attached.

The end of the connector is an exposed glass surface. This is fragile, take care not to damage it. Keep the protective caps in place when not in use.

Do not let the SLC dangle over sharp corners.

Do not place anything heavy on the SLC. Do not allow a heavy object to fall on the cable. Do not stand on the cable.

Prevent any contamination of the connectors. See Cleaning the SLC on page 178 for information on cleaning a contaminated SLC.

Do not disassemble the optical connectors.



Notes

Laser Safety Precautions

 **Warning! Death or Serious Injury could occur if the following precautions are ignored**

 **Permanent/Temporary Blindness Hazard**

Do not look directly into the lens when the light source is on. The high brightness can cause permanent eye damage.

 **Caution – use of controls or adjustments or performance of procedures other than those specified herein may result in hazardous radiation exposure.**

Do not attempt to operate the product without covers in place.

This product (MLS) has a built in Class 4 laser module. Do not attempt to disassemble or modify the laser module.

Lens Change should only be carried out by instructed and skilled persons in accordance with the Important Information document or User Manual. If in doubt consult your dealer.

Ensure the projector is switched off and AC power removed before attempting a lens change

Laser Risk Group 3 Precautions

 Not for household use.

 **Class 1 Laser Product, BS EN IEC 60825-1:2014.**
No direct exposure to the beam shall be permitted, RG3 BS EN IEC 62471-5:2015.

Operators shall control access to the beam within the hazard distance or install the product at a height that will prevent exposure of the spectator's eyes within the hazard distance. See Light Hazard Distance and Hazard Zone on page 37 for more information.

The product should be installed and operated in accordance with the provisions of BS EN IEC 62471-5:2015 and the Important Information document or User Manual by instructed and skilled persons only (BS EN IEC 62368-1:2020).

Notes



See Satellite Head on page 152 for details about the labels that are located on the Satellite Head, MLS, SCM and SLC.

Risk Group 3 Laser Hazard Installation Precautions



Do not attempt to access the internal hardware of the projector. Do not attempt to modify or remove the laser module.

Do not operate the projector without its protective covers.

Please make sure that the Satellite system is fully powered down and disconnected from the mains before changing the lens.

FDA regulations requires that a lens hood is permanently fitted when using the 2.53 - 4.98 : 1 zoom lens (4K) or 2.70 - 5.31 : 1 zoom lens (8K) with the Insight Laser range of projectors in the United States of America. This lens will be supplied with the lens hood pre-fitted.

Do not operate the projector without a lens installed.

Laser Risk Group 3 Installation Precautions



This product is a Class 1 Risk Group 3 laser product. It must be installed in a safe place and must be handled by qualified and professionally trained personnel.

Operators shall control access to the beam within the hazard distance or install the product at a height that will prevent exposure of the spectator's eyes within the hazard distance.

The product should be installed and operated in accordance with the provisions of BS EN IEC 62471-5:2015 and the Important Information document or User Manual by instructed and skilled persons only (BS EN IEC 62368-1:2020).

Light Hazard Warning



No direct exposure to the beam is permitted, RG3 BS EN IEC 62471-5:2015.

Operators should control access to the beam within the hazard distance or install the projector at sufficient height to prevent exposures of spectators' eyes within the hazard area.

When the laser is installed overhead, allow a minimum of 3m between the floor surface and the Risk Group 3 area.

Notes

Light Hazard Distance and Hazard Zone

The hazard distance is the distance measured from the projection lens at which the intensity or energy per unit of surface is lower than the applicable exposure limit on the cornea or skin. ①

The hazard zone is the area from the projection lens up to the hazard distance that encompasses where the projected beam is considered hazardous. ②

If the person is within the hazard zone, the beam is considered unsafe for exposure.

The hazard distance for this projector is related to the fitted lens and the light output at the Satellite Heads.

In order to meet Class 1 RG3 designation, the 2.53 - 4.98 : 1 zoom lens must be used with a designated hood in the 4:1 configuration. The following table gives the Hazard Distances, assuming lens D is used with a hood.

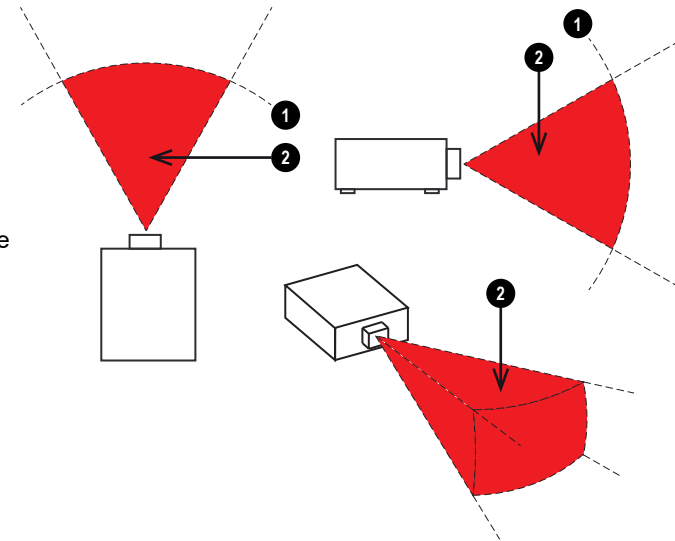

Notes

The light output at each satellite head is related to the total light output from the MLS and the number of heads. See Laser Parameters on page 6 for more information on the light output.

Operators should control access to the beam within the hazard distance or install the projector at sufficient height to prevent exposures of spectators' eyes within the hazard area.

When the laser is installed overhead, allow a minimum of 3m between the floor surface and the Light Hazard Zone.

Light output (klm) at each Satellite Head	Hazard Distance (m)			
	0.93 : 1 fixed	1.13 - 1.72 : 1 zoom	1.65 : 2.60 : 1 zoom	2.53 - 4.98 : 1 zoom with Hood
2.5 klm	0.00	0.03	0.21	1.00
3.3 klm	0.03	0.08	0.32	1.45
5 klm	0.09	0.20	0.53	2.36
10 klm	0.28	0.55	1.15	5.09
15 klm	0.45	0.95	1.95	8.80
20 klm	0.65	1.26	2.40	10.55
30 klm	1.03	1.96	3.65	16.00
40 klm	1.41	2.66	4.90	21.46

Restriction Zone

A restriction zone should be in place around the hazard zone to prevent any person from entering the hazard zone with any part of their body:

- Horizontal clearance **1**. This should be no less than 2.5m around the hazard zone **2**.
- Vertical clearance **3**. This should be no less than 3m between the hazard zone **2** and the floor when the projector is installed overhead.

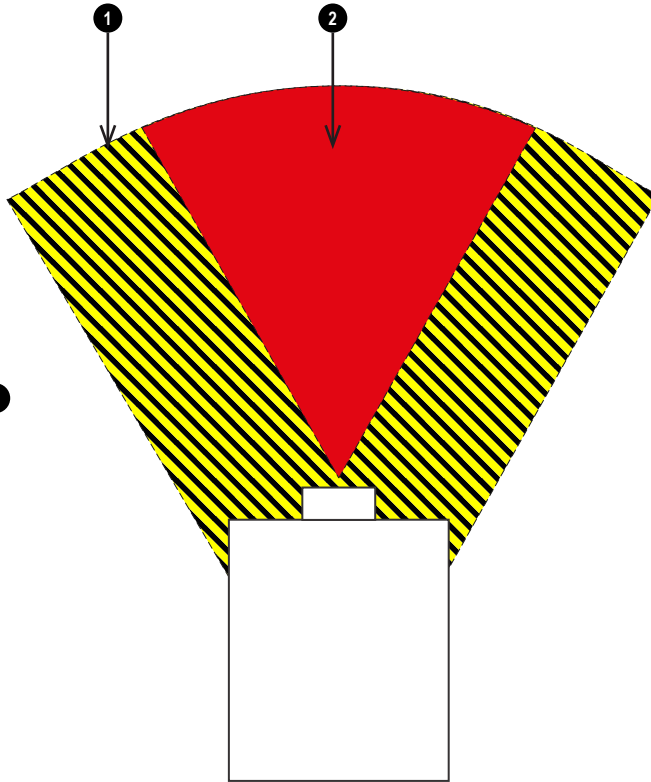

Hazard Zones - Horizontal Clearance (Top View)

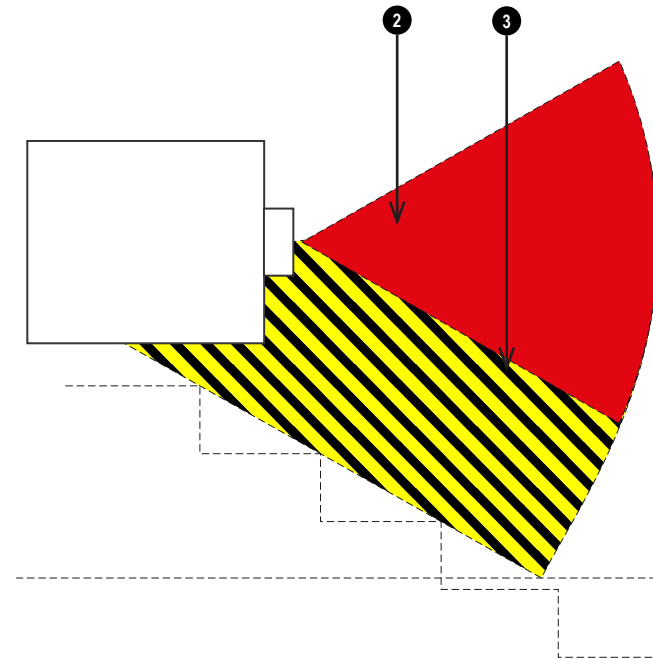

Hazard Zones - Vertical Clearance (Side View)

Notes

Fitting a lens

Inserting a new lens

1. Remove the lens aperture cap from the Satellite Head
2. Remove the lens caps from the lens
3. Align the lens with the lens mount and insert the lens:
 - Use the motor connector to orient the lens with the lens mount
 - The indentation on the lens ring should be aligned with the top of the lens mount
 - Three locating studs **1** on the lens should be aligned with the three slots **2** on the lens mount

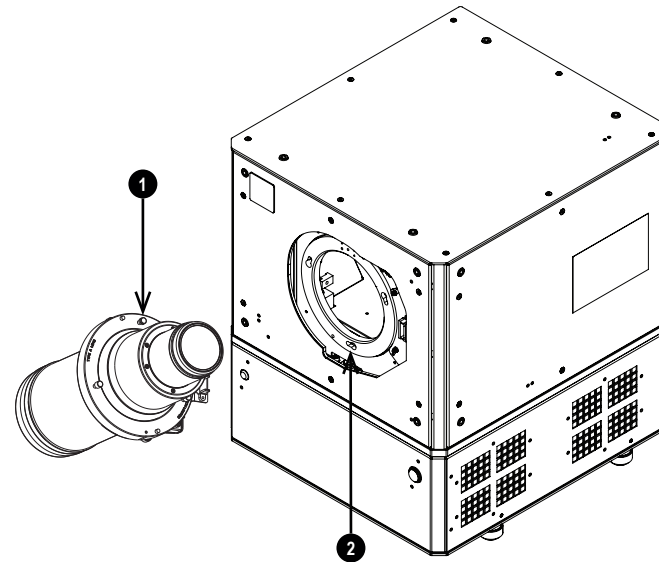

Notes

 **The system must be fully turned off prior to attempting a lens change.**

 **When changing the lens, avoid using excessive force as this may damage the equipment.**

 **Avoid touching the surface of the lens as this may result in image impairment.**

FDA regulations requires that a lens hood is permanently fitted when using the 2.53 - 4.98 : 1 zoom lens (4K) or 2.70 - 5.31 : 1 zoom lens (8K) with the Insight Laser range of projectors in the United States of America. This lens will be supplied with the lens hood pre-fitted.

 *The lens is shipped separately.*

 *Take care to preserve the original lens packaging and protective caps for future use.*

 *The Modular Light Source will not turn on without a lens fitted.*

 *When a new lens is fitted into the projector, it must be calibrated. See Lens Calibrate on page 93.*

 *See Choosing a lens on page 163 for details about the lenses available for the Satellite Head.*

4. Rotate the lens clockwise ③ until the locating studs are all the way into the slots
5. Tighten the two fixing screws ④ on the lens collar

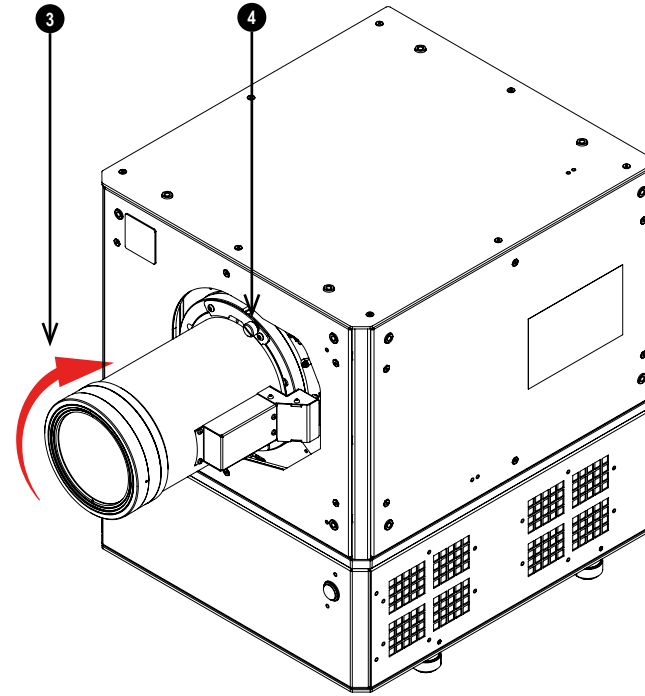
**Notes**

Removing the lens

1. Loosen the two fixing screws on the lens collar
2. Rotate the lens anti-clockwise until the locating studs are out of the slots, then pull the lens out.
3. Fit the lens caps to the lens

Fitting a lens hood

A lens hood can be fitted to the lens before the lens is inserted.

1. Align the guide pin on the adapter ring with the slots on the lens hood and fit the adapter to the lens hood ①
2. Insert and tighten the six fixing screws to secure the adapter ring to the lens hood ②

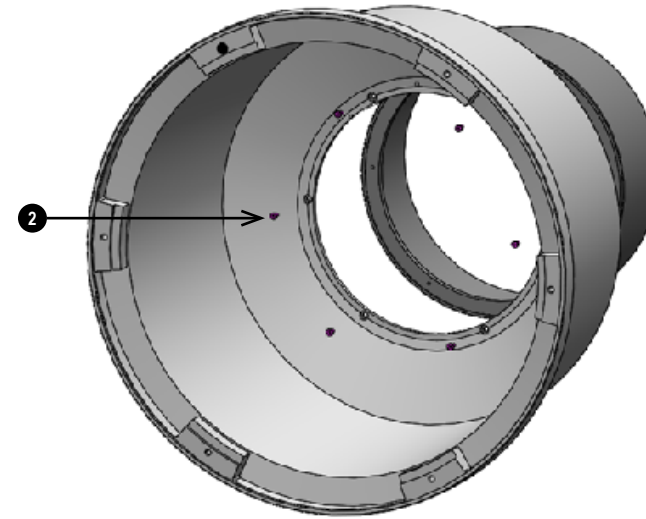
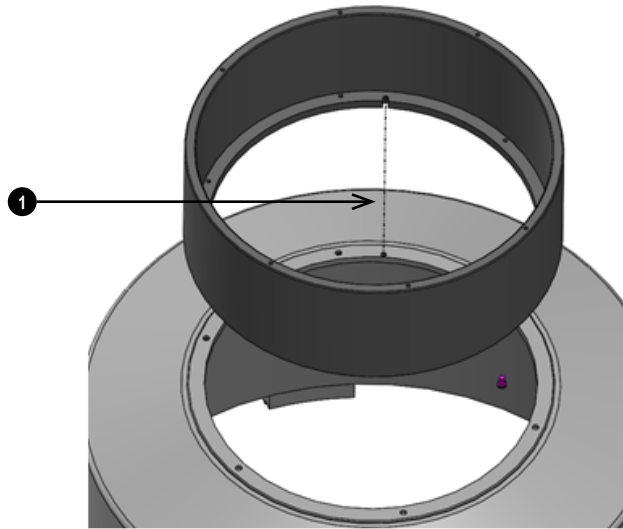

3. Place the lens glass over the lens hood. Make sure the glass is located correctly ③

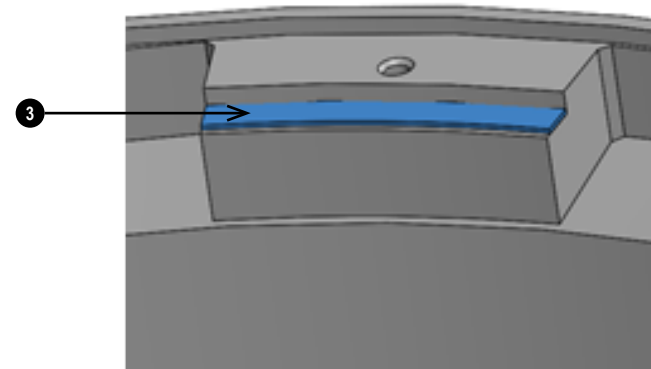

Notes

FDA regulations requires that a lens hood is permanently fitted when using the 2.53 - 4.98 : 1 zoom lens (4K) or 2.70 - 5.31 : 1 zoom lens (8K) with the Insight Laser range of projectors in the United States of America. This lens will be supplied with the lens hood pre-fitted.

4. Place the plate over the lens glass ④
5. Insert and tighten the six fixing screws to secure the plate and lens glass to the lens hood ⑤

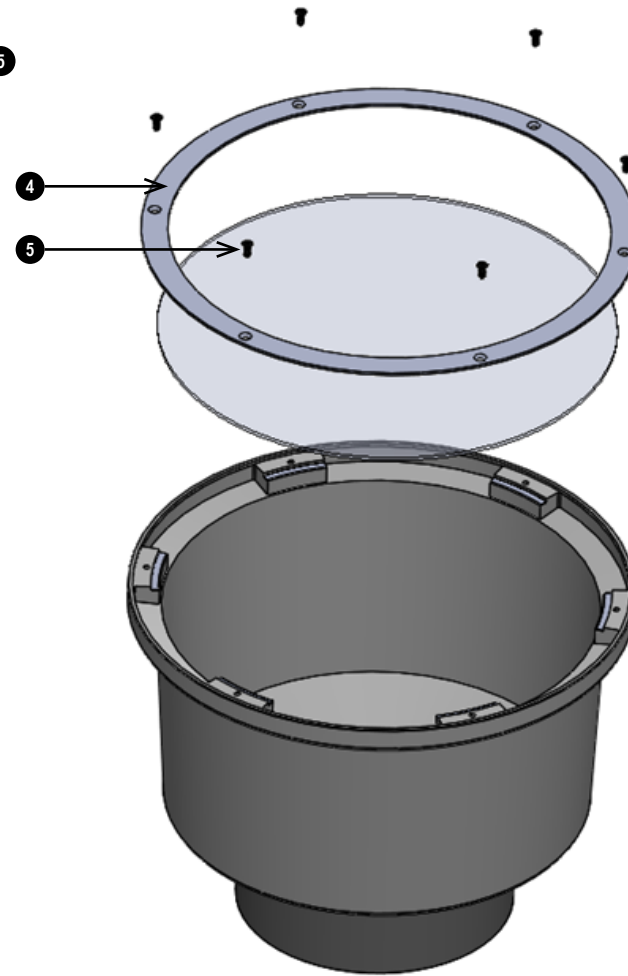

Notes

6. Insert the lens into the adapter ring. Make sure the plate ring **6** is located against the adapter ring.
7. Insert and tighten the six fixing screws to secure the lens to the lens hood **7**

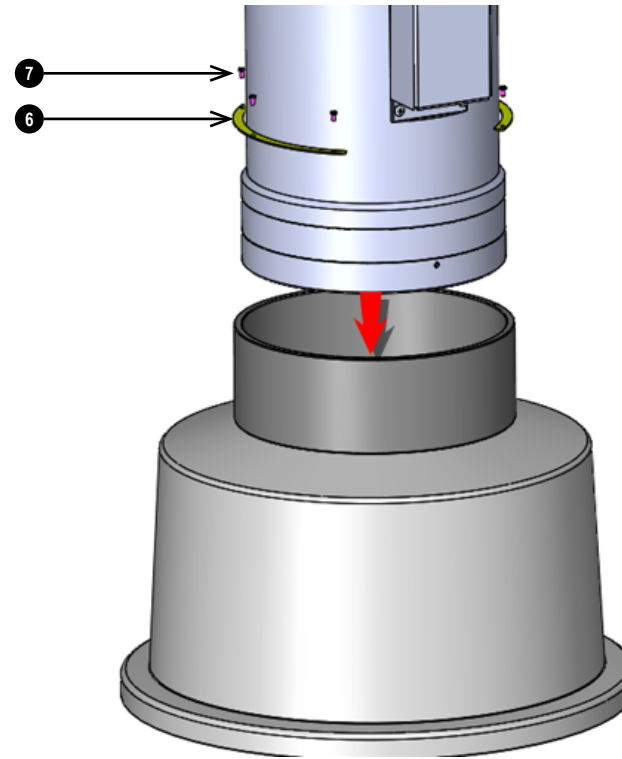
**Notes**

Positioning the screen and Satellite Head

1. Install the screen, ensuring that it is in the best position for viewing by your audience.

2. Mount the Satellite Head, ensuring that it is at a suitable distance from the screen for the image to fill the screen.

The drawing shows the positions of the mounting points:

- **Four adjustable feet for tabletop mount ①.**

Set the adjustable feet so that the Satellite Head is level, and perpendicular to the screen.

Remove the feet and fit them to the top of the Satellite Head if you need to invert the Satellite Head during tabletop use.

- **Four M6 holes for ceiling mount ①.**

Remove the adjustable feet if you need to invert the Satellite Head for a ceiling mount.

The mounting screws should not penetrate more than 15 mm into the body of the projector.

- **Four M6 holes for ceiling mount ②.**

The mounting screws should not penetrate more than 15 mm into the body of the projector.

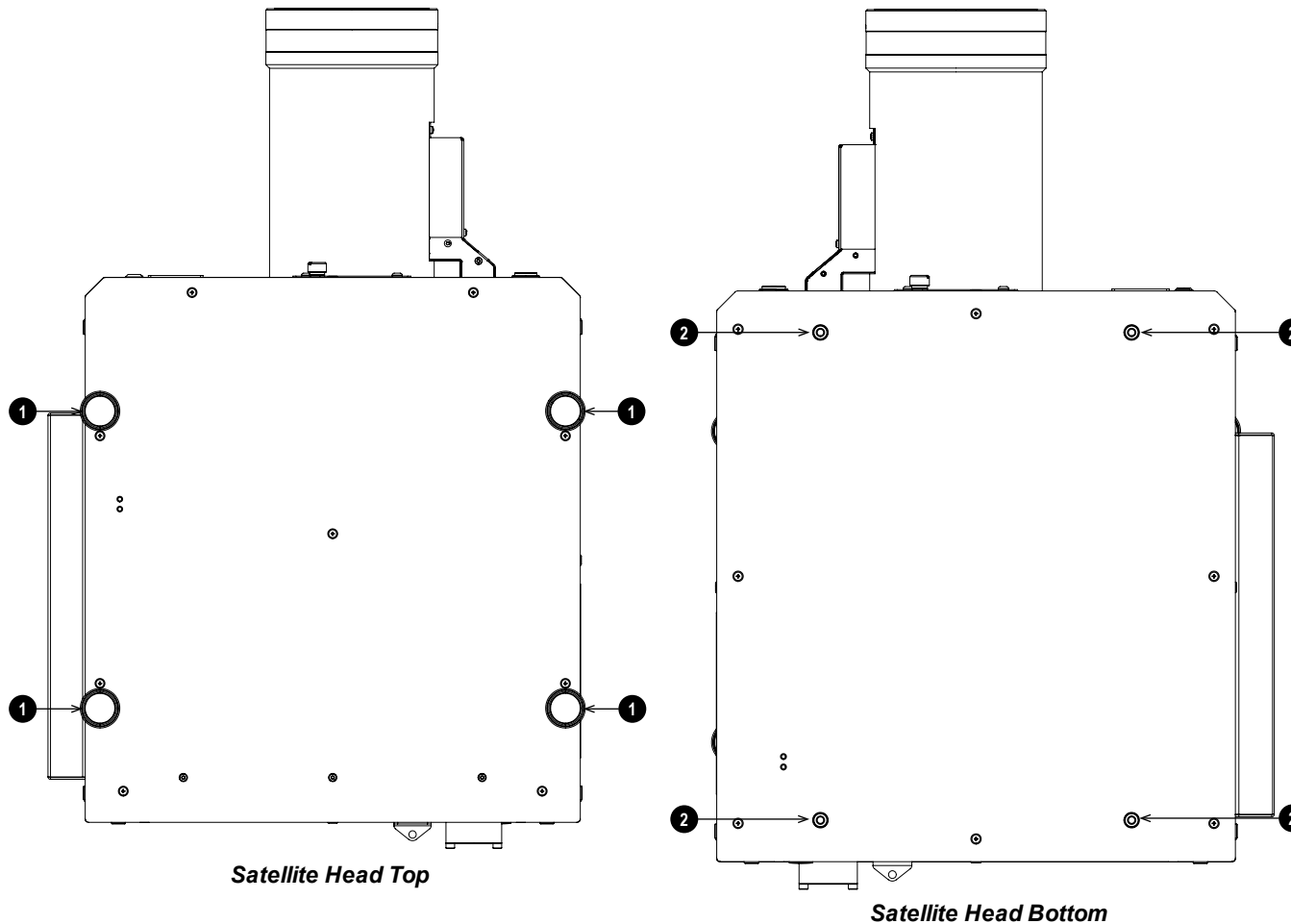

Notes



Always allow the Satellite Head to cool for 5 minutes before disconnecting the power or moving the Satellite Head.



Ensure that there is at least 50 cm (19.7 in) of space between the ventilation outlets and any wall, and 30 cm (11.8 in) on all other sides.



Avoid extending the adjustable feet to the limit of the thread.

Mounting the rack mount modules

1. Fit any shelves or rails to the rack as required.
2. Fit any rails or mount supports to the Modular Light Source (MLS) or Satellite Control Module (SCM) as required.
3. Mount the module into the rack and secure in place with 4 standard rack locating bolts

MLS 10000

The drawing shows the positions of the fixing holes for the mount supports and rack locating bolts on the MLS.

1. **Four standard rack locating bolt holes** ①.
2. **Six M4 fixing holes** ② for mounting rails or supports. The screws should not penetrate more than 10 mm into the body of the MLS.

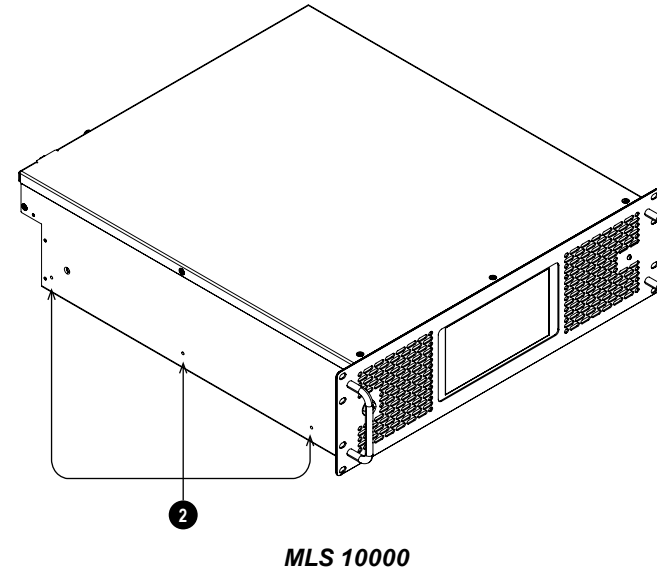
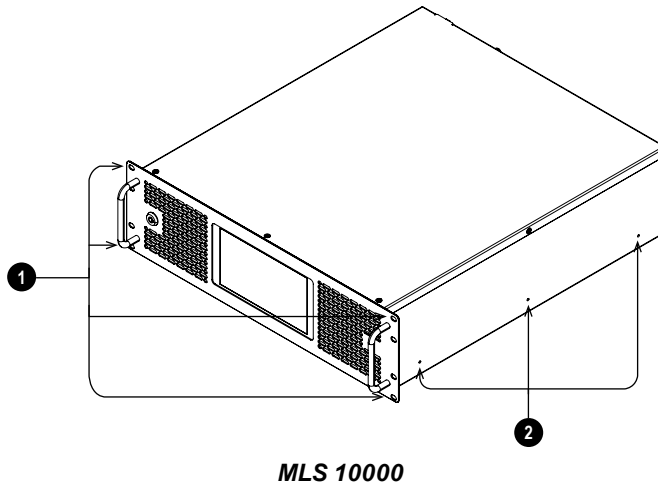

Notes

MLS 20000/MLS 30000

The drawing shows the positions of the fixing holes for the mount supports and rack locating bolts on the MLS.

1. **Four standard rack locating bolt holes ①.**
2. **Six M4 fixing holes ② for mounting rails or supports.** The screws should not penetrate more than 10 mm into the body of the MLS.

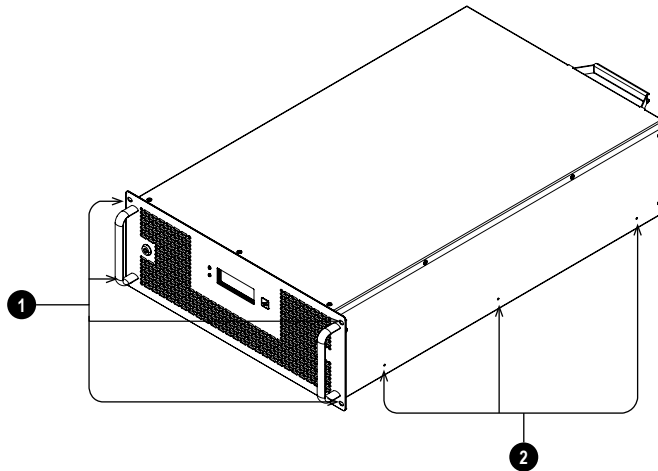

MLS 20000/MLS 30000

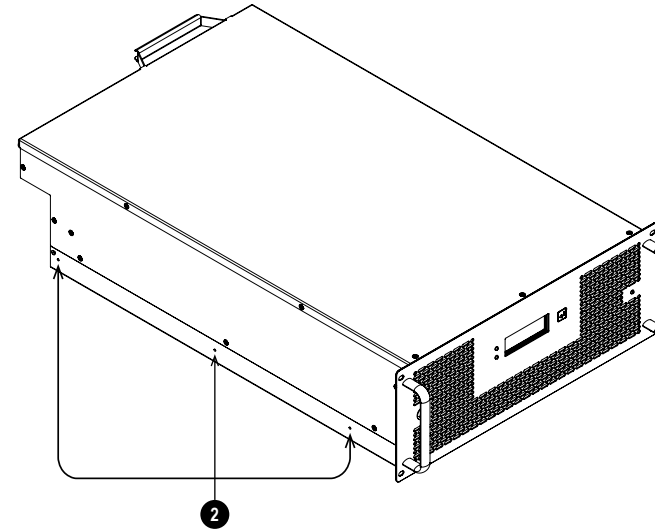

MLS 20000/MLS 30000

SCM

The drawing shows the positions of the fixing holes for the mount supports and rack locating bolts on the SCM.

1. **Four standard rack locating bolt holes ①.**
2. **Four M4 fixing holes ② for mounting rails or supports.** The screws should not penetrate more than 15 mm into the body of the SCM.

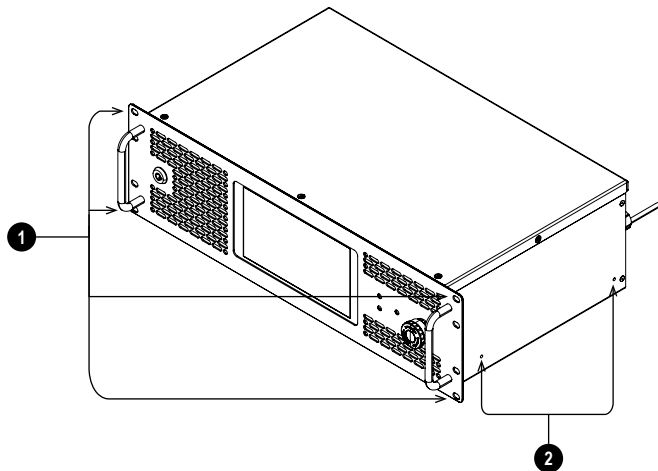

SCM

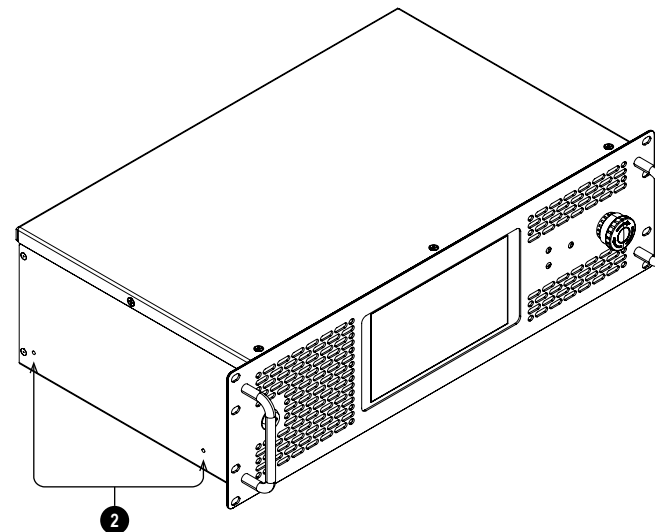

SCM

Notes

Connecting the Satellite Link Cable

The Satellite Link Cable (SLC) must connect each Satellite Head to one or more Modular Light Sources (MLS). The type of SLC that is supplied depends on the number and type of connections required for your system:

- 1:1. This system uses a single end-to-end cable to connect a single MLS to a single Satellite Head.
- n:1. This system connects between two and four MLS to a single Satellite Head. A single cable is supplied for this purpose. The cable includes a junction box with multiple MLS connectors extending from one side and one Satellite Head connector extending from the other.
- 1:n. This system connects a single MLS to between two and four Satellite Head. A single cable is supplied for this purpose. The cable includes a junction box with a single MLS connector extending from one side and multiple Satellite Head connectors extending from the other.

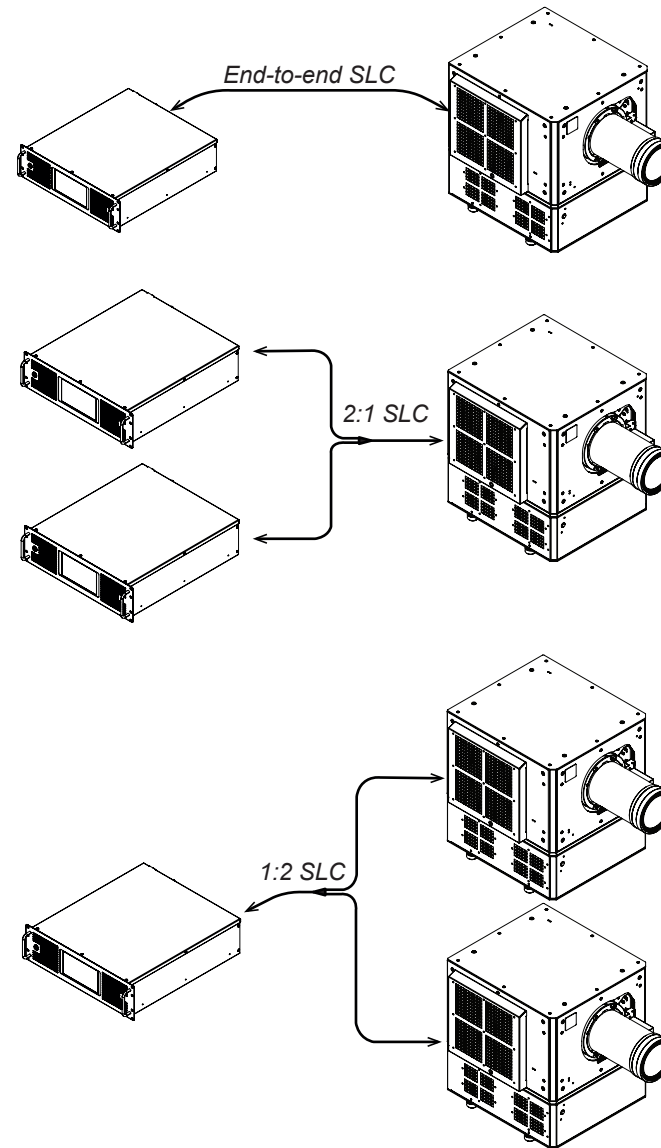

Notes

Handle the SLC with care. Do not drop or knock the SLC when removed from its packaging. The curvature of the SLC should never have a radius of less than 20 cm. Below this, the fiber inside the cable may be damaged.



The appropriate SLC cables are supplied with the system. Use only the SLC cable provided.



It may be necessary to clean the SLC connectors before installation. See Cleaning the SLC on page 178



The connectors at each end of the SLC are identified by polarity pins and holes:

- A connector with a polarity hole **1** can only connect to a MLS.
- A connector with two polarity holes **1** can only connect to a MLS.
- A connector with a polarity pin **2** can only connect to a Satellite Head.

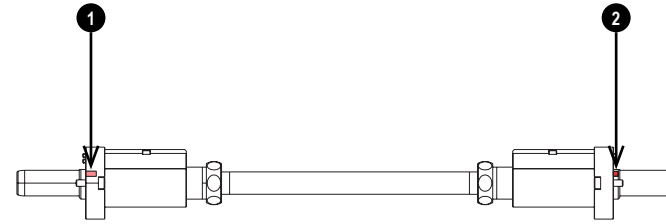

To fit the SLC to the Satellite Head :

1. Remove the end cap from the SLC-Satellite Head connector.
2. Remove the protective cap from the SLC socket on the Satellite Head **1**.
3. Align the polarity pin on the SLC **2** with the polarity hole on the SLC socket.
4. Insert the SLC.
5. Use the hex driver to screw in the fixing screw on the SLC and secure it in place.

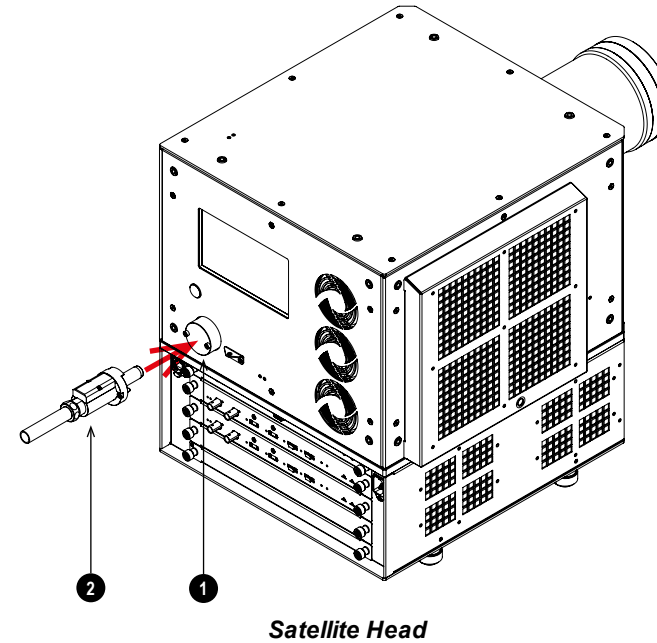

Notes

To fit the SLC to the MLS:

1. Remove the end cap from the SLC-MLS connector.
2. Slide the protective cover on the SLC socket on the MLS open **1**.
3. Align the polarity hole on the SLC **2** with the polarity pin on the SLC socket.
4. Insert the SLC.
5. Use the hex driver to screw in the fixing screw on the SLC and secure it in place.

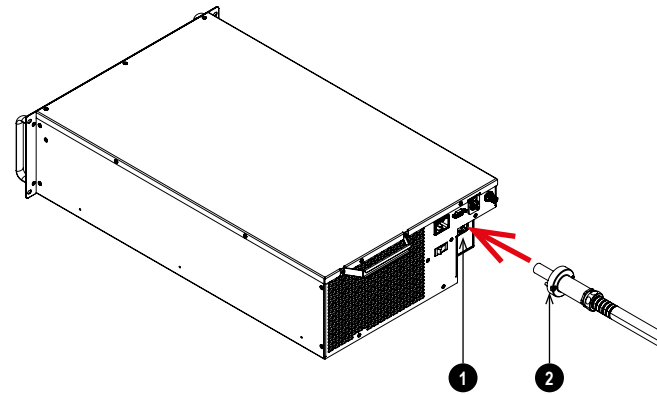
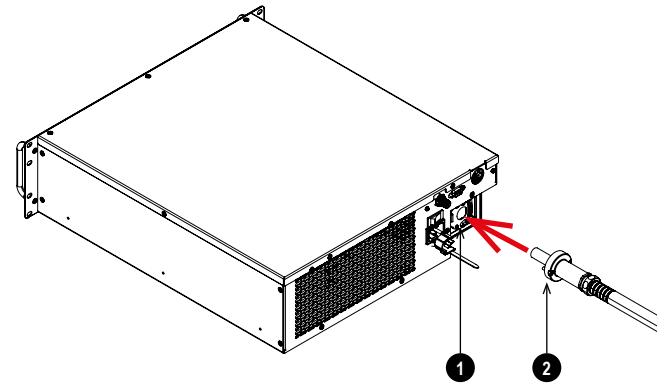

Notes

Connecting the Signal and LAN cables

Each Modular Light Source (MLS) must be connected to the Satellite Control Module (SCM) with a signal cable and a LAN cable. Each Satellite Head must be connected to the SCM with a LAN cable.

- 1:1. One MLS and one Satellite Head are connected to the SCM.
- n:1. Up to four MLS and one Satellite Head can be connected to the SCM.
- 1:n. Up to four Satellite Head and one MLS can be connected to the SCM.

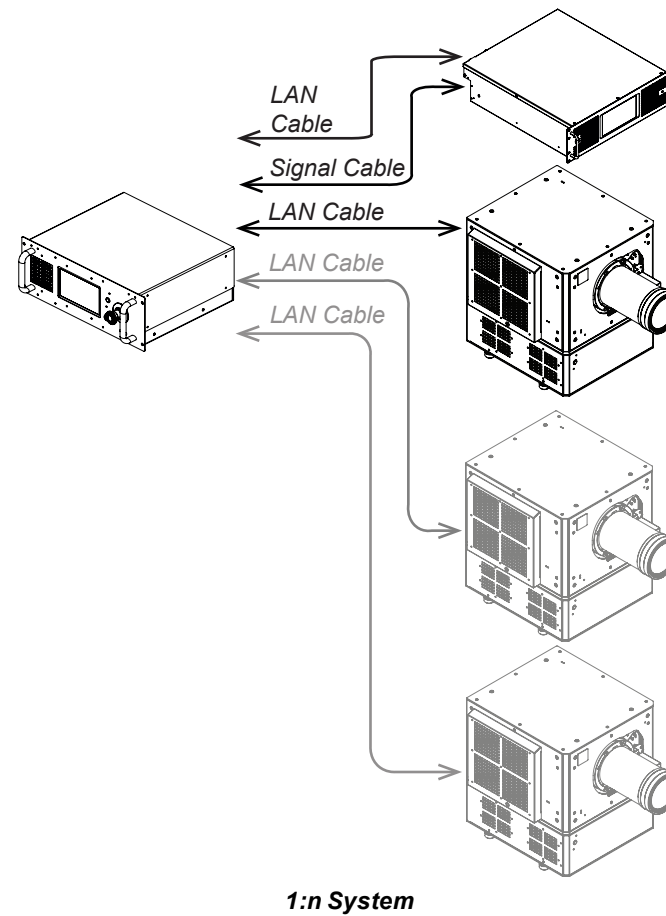
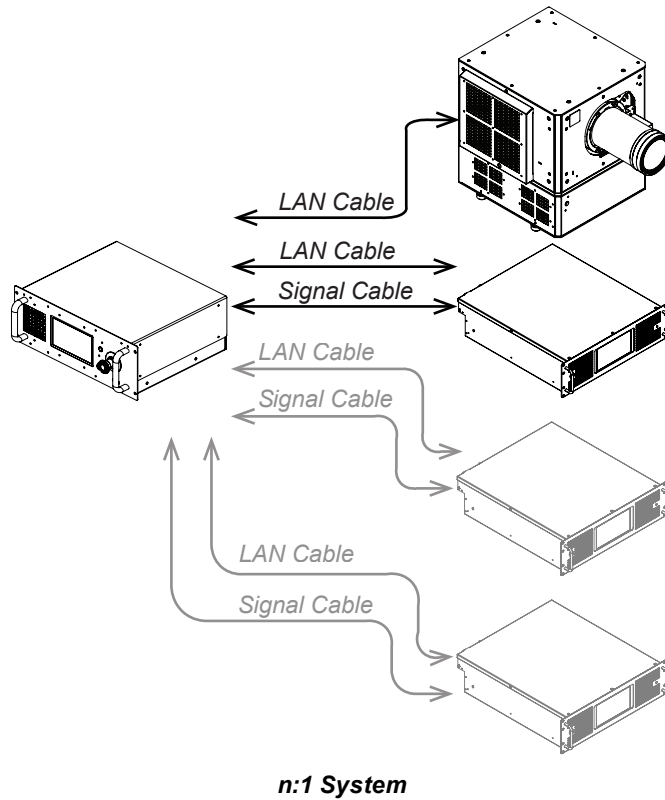

Notes

The appropriate cables are supplied with the Satellite MLS. A single signal cable is supplied for each MLS and a single LAN cable is supplied for each MLS and Satellite Head. Use only the cables provided.

A single LAN port **1** is located on the rear of the Satellite Head.

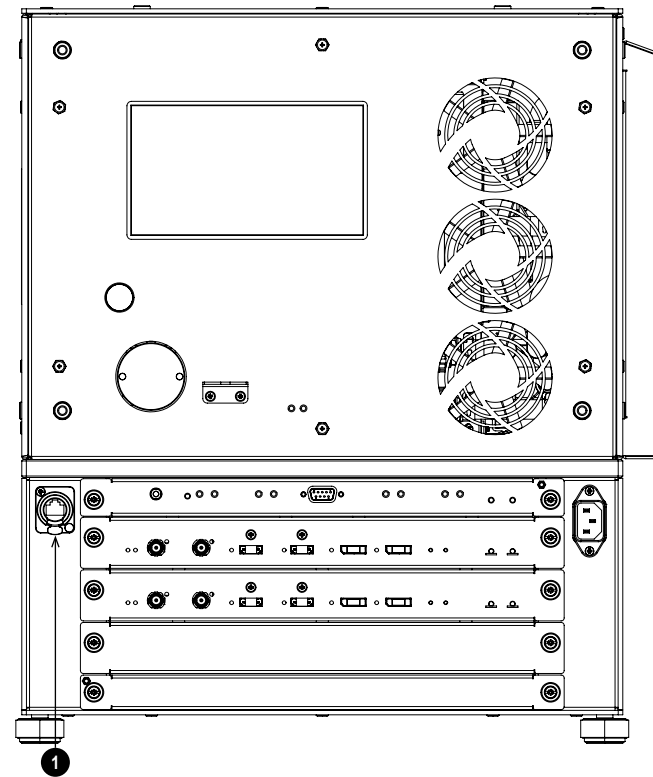

Satellite Head

Notes

A single signal cable port **2** and a single LAN port **3** are located on the rear of the MLS.

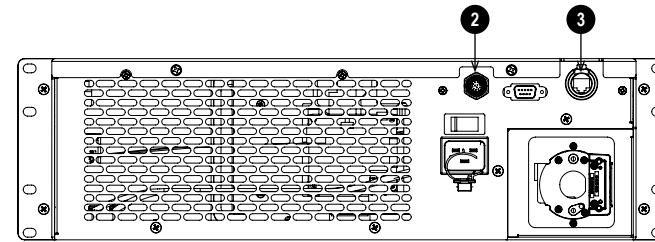

MLS 10000

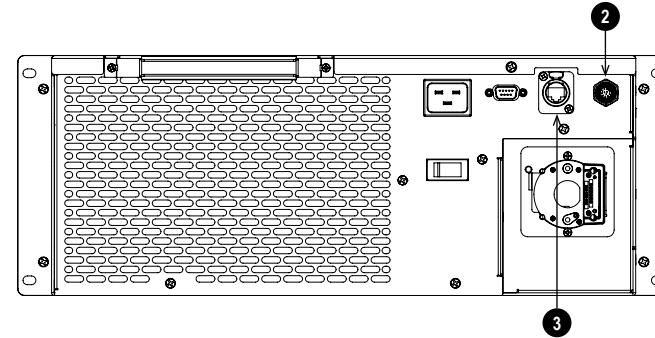

MLS 20000/MLS 30000

There are four signal cable ports **4** - **7** and five LAN ports **8** - **12** located on the rear of the SCM.

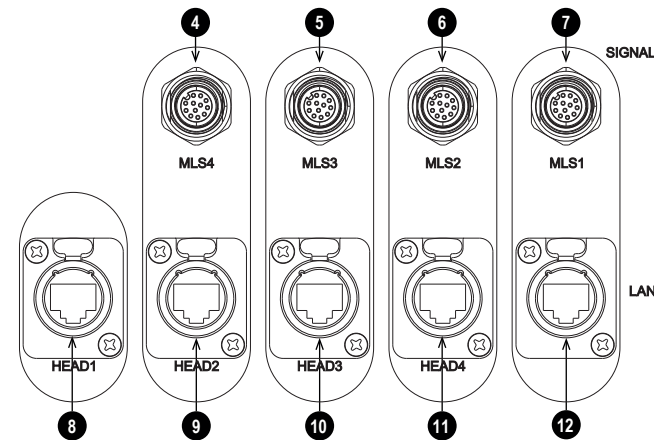

Notes

The appropriate cables are supplied with the Satellite MLS. A single signal cable is supplied for each MLS and a single LAN cable is supplied for each MLS and Satellite Head. Use only the cables provided.

Single Satellite Head and Modular Light Source - 1:1 System

Make the following connections when connecting a system with a single Satellite Head and a single Modular Light source:

1. Connect a signal cable to the MLS and connect it to the MLS 1 socket **1** on the SCM.
2. Connect a LAN cable to the MLS and connect it to the MLS 1 LAN socket **3** on the SCM.
3. Connect a LAN cable to the Satellite Head and connect it to the Head 1 socket **2** on the SCM.

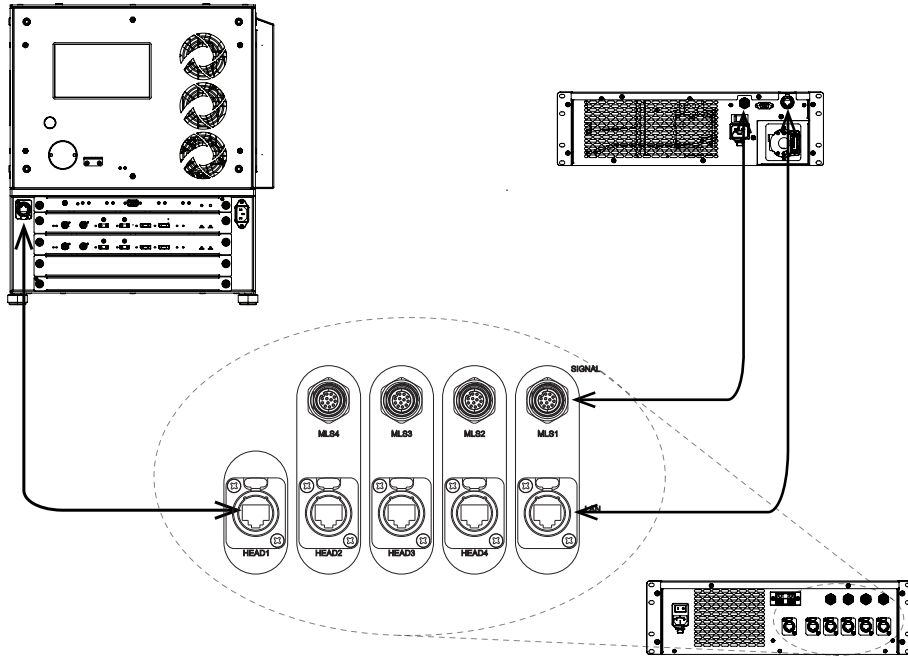

Example of a 1:1 system configuration

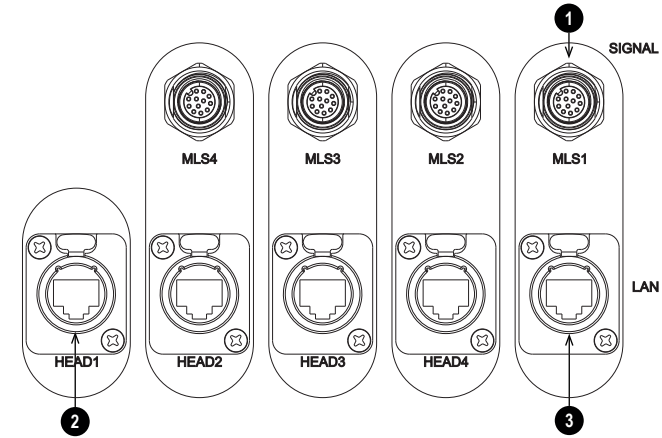

Notes

Multiple Modular Light Sources - n:1 System

Make the following connections when connecting multiple MLS:

1. First MLS:

- Connect a signal cable to the first MLS and connect it to the MLS 1 socket **4** on the SCM.
- Connect a LAN cable to the first MLS and connect it to the MLS 1 LAN socket **9** on the SCM.

2. Second MLS:

- Connect a signal cable to the MLS and connect it to the MLS 2 socket **3** on the SCM.
- Connect a LAN cable to the MLS and connect it to the MLS 2 LAN socket **8** on the SCM.

3. Third MLS:

- Connect a signal cable to the third MLS and connect it to the MLS 3 socket **2** on the SCM.
- Connect a LAN cable to the third MLS and connect it to the MLS 3 LAN socket **7** on the SCM.

4. Fourth MLS:

- Connect a signal cable to the fourth MLS and connect it to the MLS 4 socket **1** on the SCM.
- Connect a LAN cable to the fourth MLS and connect it to the MLS 4 LAN socket **6** on the SCM.

5. Connect a LAN cable to the Satellite Head and connect it to the Head 1 socket **5** on the SCM.

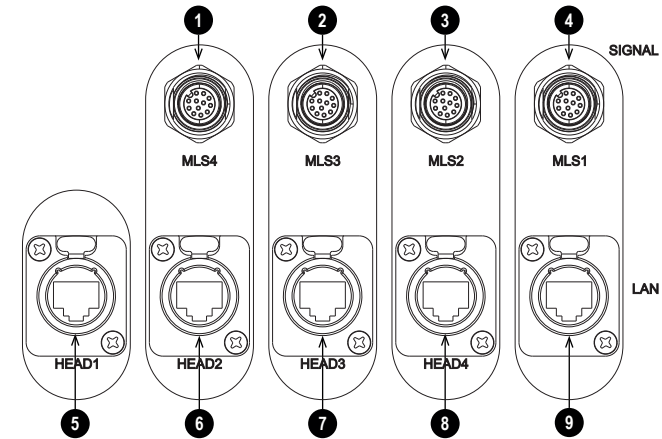

Notes

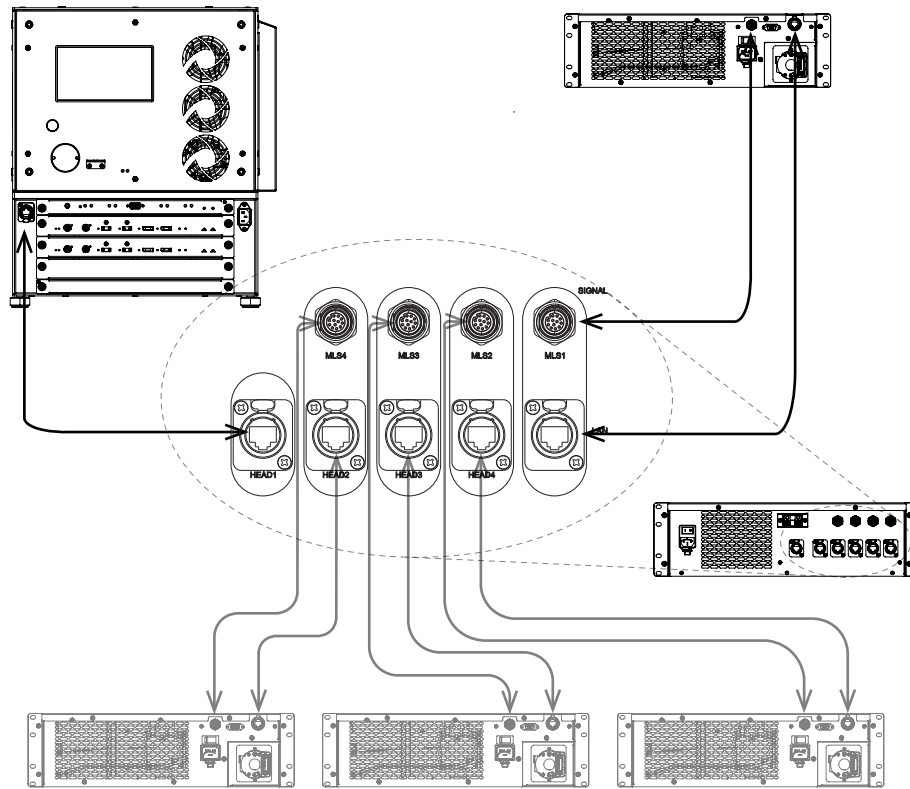

Example of an n:1 system configuration

Notes

Multiple Satellite Projector Heads - 1:n System

Make the following additional connections when connecting multiple Satellite Heads:

1. Connect a signal cable to the MLS and connect it to the MLS 1 socket **1** on the SCM.
2. Connect a LAN cable to the MLS and connect it to the MLS 1 LAN socket **6** on the SCM.
3. Connect a LAN cable to the first Satellite Head and connect it to the Head 1 socket **2** on the SCM.
4. Second Satellite Head:
 - Connect a LAN cable to the Satellite Head and connect it to the Head 2 LAN socket **3** on the SCM.
5. Third Satellite Head:
 - Connect a LAN cable to the Satellite Head and connect it to the Head 3 LAN socket **4** on the SCM.
6. Fourth Satellite Head:
 - Connect a LAN cable to the Satellite Head and connect it to the Head 4 LAN socket **5** on the SCM.

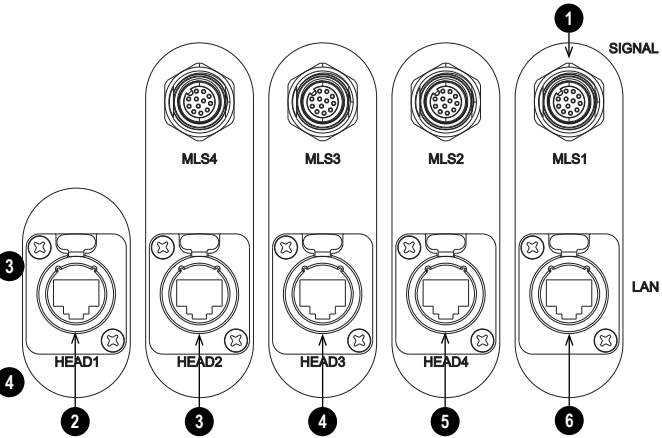

Notes

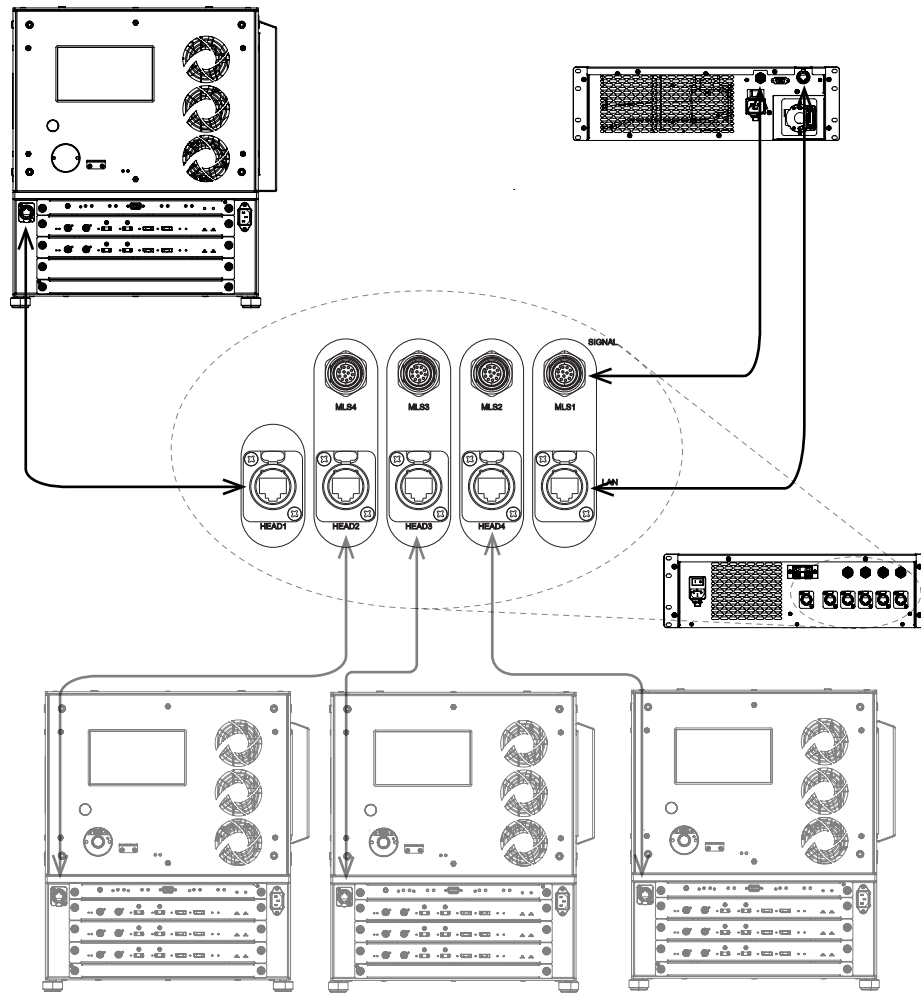

Example of a 1:n system configuration

Notes

Power Supply

Notes

AC Power Precautions



Warning! Death or Serious Injury could occur if the following precautions are ignored

Shock Hazard! Only use the AC power cord provided or recommended by the manufacturer

Fire & Shock Hazard! Do not operate the product unless the power cord, socket and plug meet local rating standards

Do not attempt operation if the AC supply is not within the specified parameters

The AC power cord must be inserted into a socket with grounding

Disconnect the product from the AC supply before installing, moving, servicing, cleaning or removing covers

Do not use an AC power cord that appears damaged

Do not overload power sockets or extension cords

Connecting the power supply

1. Firmly push the mains connector into the AC socket **1**

When the cable is plugged in and the power supply is on, the module is ON.

When power is applied to the MLS the Laser illumination is not switched on.

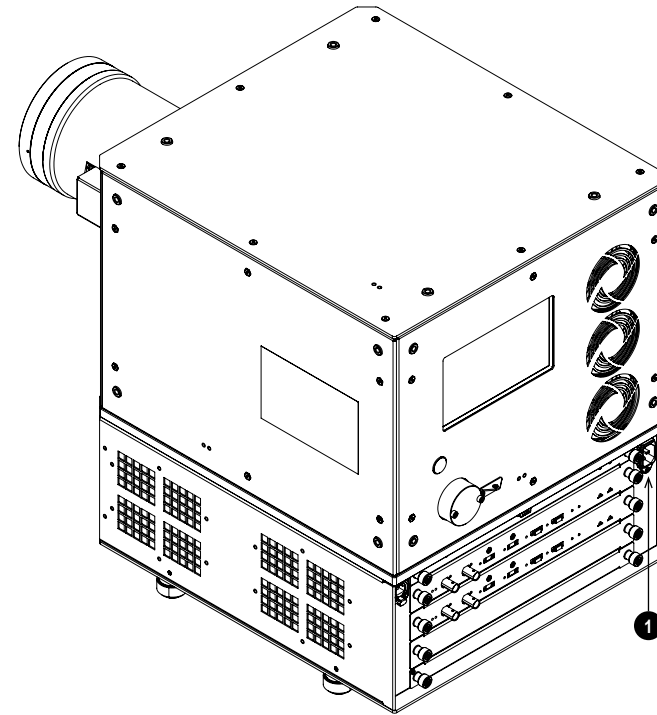

Satellite Head

Notes



Use only the power cable provided.



Ensure that the power outlet includes a ground connection as this equipment **MUST** be earthed.



Handle the power cable carefully and avoid sharp bends. Do not use a damaged power cable.

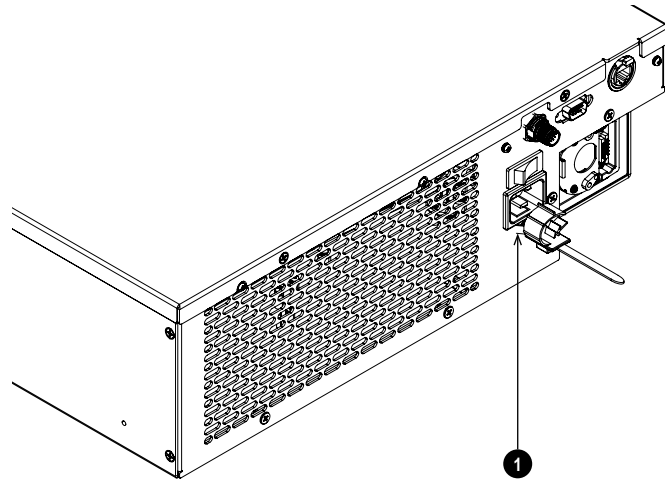

MLS 10000

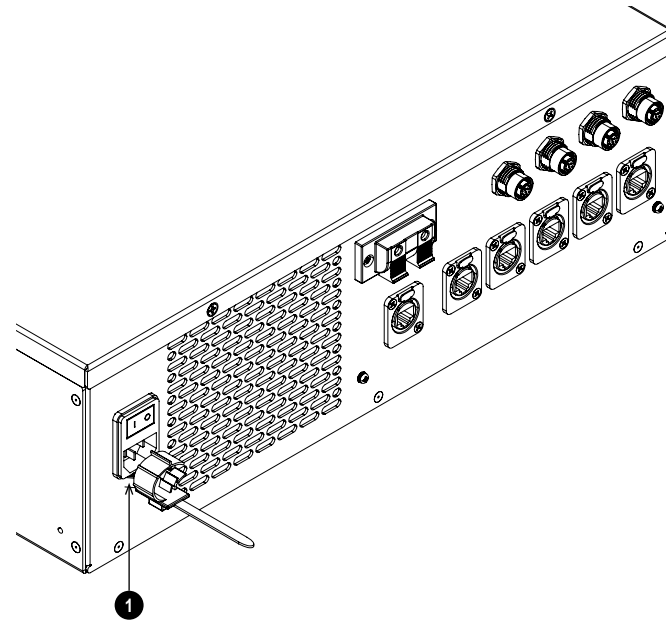

SCM

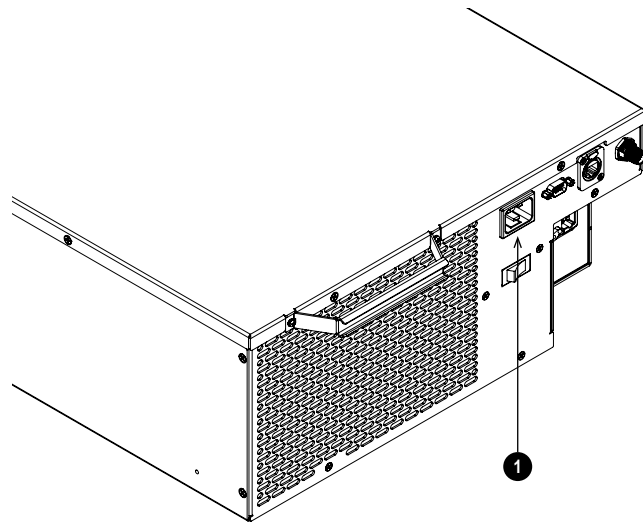

MLS 20000/MLS 30000

Notes

Basic Operating Instructions

Switching the system on

1. Make sure lenses are fitted to each Satellite Head
2. Make sure the Signal, LAN and SLC cables are fitted
3. Make sure power cables are fitted to the Satellite Head, MLS and SCM
4. Make sure the power supply is on
5. Use the power switch located on the power cable socket to apply power to:
 - The MLS
 - The SCM
6. Insert the laser on key into the laser on switch on the SCM and each MLS and turn to enable
7. Press **ON** on the Remote Control, or;
 - Tap **Laser On** in the Laser Power Page on the Satellite Control Module touch panel

Switching the projector off

1. Press **OFF** on the Remote Control, or;
 - Tap **Laser Off** in the Laser Power Page on the Satellite Control Module touch panel
2. Turn the laser on key on the SCM and each MLS to disable.

Emergency off

In an emergency, press the **Emergency OFF** button on the front of the Satellite Control Module to turn off the Laser Illumination

Notes



See *Operating the system* on page 65 for guidance on the projector controls.



Make sure the projector is fully installed, all interlocks are in place and the laser key switch on the SCM and each MLS are enabled before switching the projector on.

Interlock reset

In the event of the laser illumination turning off as a result of an Interlock break:

1. Make sure all interlocks are in place. See Interlock Switches on page 25
2. Turn ON the laser illumination. See Switching the system on on the previous page

Setting the Number of MLS

It is important to set the number of MLS in the software after the system has been installed.

Use the touchscreen on the Satellite Head or SCM to set the number of MLS:

1. Navigate to the Laser Power menu on the Touchscreen:
 - Satellite Head, Main Menu > System > Laser Power
 - SCM, Main Menu > System
2. Set the Number of MLS.

Selecting an input signal

1. Connect one or more image sources to the projector.
2. Select the input you want to display:
 - Press one of the input buttons on the remote control or control panel.
 - Alternatively, open the On-screen display (OSD) by pressing **MENU**. Highlight **Input** from the main menu, press **ENTER/OK** and then select an input signal using the **UP** and **DOWN** arrow buttons. Press **ENTER/OK** to confirm your choice.

Selecting a test pattern

The following test patterns are available: *Off, ANSI Chequerboard, Colour Bars, Alignment, Native White, Native Black, Native Red, Native Green and Native Blue.*

Use one of the following methods to display a test pattern:

- Press **TEST** on the remote control.
Use the **LEFT** and **RIGHT** arrow buttons to cycle through the test patterns.
- Press **MENU** open the OSD. Highlight **Test Patterns** from the main menu, then select a test pattern using the **LEFT** and **RIGHT** arrow buttons.

After the final test pattern, the projector exits test pattern mode and returns to the main image. To view test patterns again, you need to press **TEST** again. If you wish to exit the test patterns before you reach the final one, press **TEST** or **EXIT** at any time.

Notes



See Laser on page 127 for further guidance on the Satellite Head touchscreen. See Laser Power on page 146 further guidance on the SCM touchscreen.



Please refer to the connection guide for details about connecting a signal source. See Signal inputs on page 74

Adjusting the lens

You can use the following options to adjust the lens:

- Remote control. See Remote control on page 66
- On screen display (OSD).

Adjusting the image

Orientation

This can be set from the **System** menu. See System on page 1 for guidance.

Highlight **Orientation** and choose from **Desktop Front**, **Ceiling Front**, **Desktop Rear** and **Ceiling Rear**.

Picture

Settings such as **Gamma**, **Brightness** and **Contrast** can be set from the **Image** menu. See Image on page 95 for guidance.

Notes

Laser color calibration

The laser colors must be calibrated after installation or after changing MLS within a system:

1. Press **Menu** on the remote control to display the OSD on the screen
2. Use the navigation buttons to highlight the Setup menu and press **OK** to access it
3. Navigate to the System Setting menu and press **OK** to access it
4. Navigate to the Laser Color CAL function and press **OK** to recalibrate the colors.

The calibration will take approximately 30 to 40 minutes to complete.

System Setting

Orientation	Front Tabletop
High Altitude	Off
Clock Adjust	▶
Startup Logo	Original
Blank Screen	Logo
PIC Mute	▶
Smear Reduction	Off
Output Frame Rate	60Hz
HDMI Equalizer	Auto
Laser Color CAL	OK
Back	▶

Notes

Operating the system

The system has the following controls:

- Remote control
- Touchscreen control panel on the Satellite Head
- Touchscreen control panel on the MLS 10000
- Touchscreen control panel on the SCM

Satellite Head Control panel

This projector head uses a touch screen control panel. A menu is displayed when the power is on.

Each menu consists of the following elements:

- Title bar at the top shows which menu you have accessed.
- Available and unavailable items Unavailable items appear a pale gray color. Whether an item is available may depend on other settings.
- The text or symbol to the right of an item shows whether the item:
 - has a value that can be changed (the current value is shown)
 - opens a sub-menu (an arrow button is displayed)
 - executes a command (the space to the right of the item is blank).

Main Menu	
Input	▶
Lens	▶
Image	▶
3D	▶
System	▶
Information	▶

Notes

 Use the touchscreen control panel on the SCM to access the controls for the MLS 20000 and MLS 30000.

 Do not make changes to the networking configuration unless you understand what you are doing, or have taken advice from your Network Manager. If you make a mistake, it is possible that you will lose contact with the projector. Always double-check your settings before pressing the APPLY button. Always keep a written note of the original settings, and any changes you have made.

 Software updates should NOT be carried out except by, or with the supervision of, Digital Projection Service personnel.

 See *Connecting the power supply* on page 59.

 The self-test is running when all the LEDs on the control panel are lit.

See *Introduction to the OSD* on page 84 for full details of how to use the menu system.

See *Introduction to the Satellite Head Touchscreen* on page 108 for full details of how to use the Satellite Head touchscreen control panel.

 See *Introduction to the MLS 10000 Touchscreen* on page 134 for full details of how to use the MLS touchscreen control panel. See *Introduction to the SCM Touchscreen* on page 1 for full details of how to use the SCM touchscreen control panel.

Remote control

1. **Power ON / OFF**
Turns power on and off.
2. **Pic Mute OPEN / CLOSE**
 - Press CLOSE to hide the projected image. When off, the laser remains on and a black image is projected.
 - Press OPEN to display the hidden image.
3. **OSD ON / OFF**
Enable and disable screen timeout messages and control whether to show the OSD during projection.
4. **MENU**
Access the on screen display (OSD). If the OSD is open, press this button to go back to the previous menu.
5. **Navigation (arrows and OK)**
OSD mode: Navigate through the menus with the arrows, confirm your choice with **OK**.
Lens adjustment modes: See **10** below.
6. **EXIT**
Go up one level in the OSD. When the top level is reached, press to close the OSD.
7. **DEFAULT**
When editing a parameter, press this button to restore the default value.
8. **INFO**
Access information about the projector.

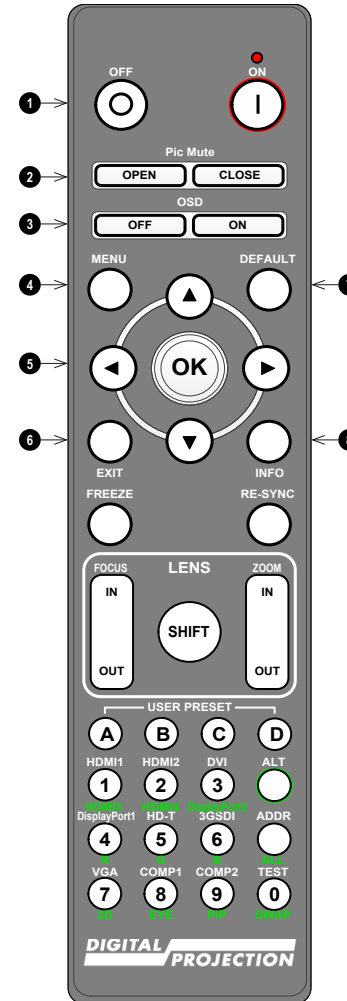

Remote Control

Notes

9. **FREEZE**
This function is not used.
10. **LENS adjustment**
 - **FOCUS IN / OUT:** adjust focus.
 - **SHIFT:** press and hold this button, then use the OK and Navigation buttons. Press OK to switch between **Shift Adjustment** and **Zoom / Focus Adjustment**. Use the arrows to shift, zoom or focus the lens.
 - **ZOOM IN / OUT:** adjust zoom.
11. **USER PRESET A, B, C, D**
These functions are not used.
12. **RE-SYNC**
Re-synchronise with the current input signal
13. **ALT**
Press and hold this button to access alternative functions for other buttons on the remote.
14. **DisplayPortA / numeric input 3**
Select the DisplayPortA input.
15. **HDMI B / numeric input 2**
Select the HDMI B input.
16. **HDMI A / numeric input 1**
Select the HDMI A input.

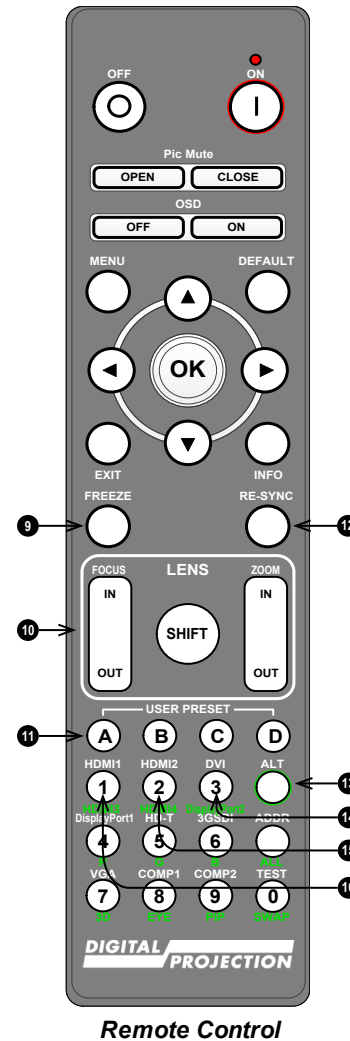

Remote Control

Notes

- 17. **DisplayPortB / numeric input 4**
Select the DisplayPortB input.
- 18. **Dual Pipe Left/Right / numeric input 5**
Select the slot 1 DisplayPort A+B input, Dual Pipe Left/Right 3D mode.
- 19. **ADDR / All**
This function is not used on this projector.
- 20. **Dual Pipe East/West / numeric input 6**
Select the slot 1 DisplayPort A+B inputs, Dual Pipe East/West 3D mode.

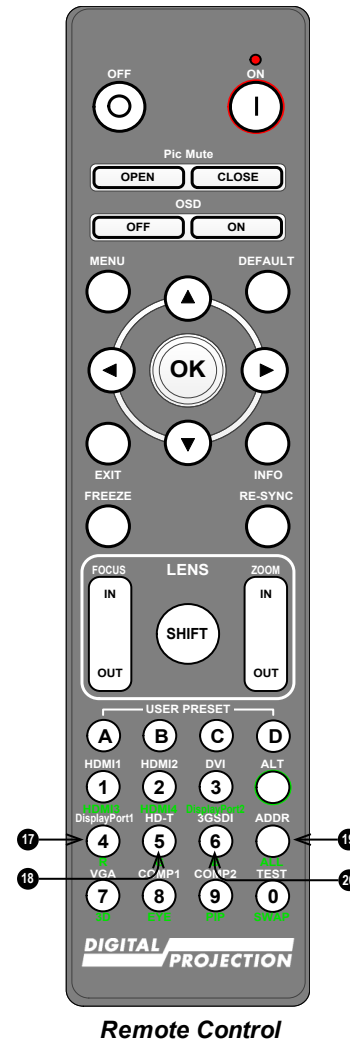

Remote Control

Notes

- 21. **DisplayPort Slot 1/2 / numeric input 7**
Select the slot 1 and 2 DisplayPort A+B inputs.
- 22. **Numeric input 8**
- 23. **TEST / SWAP / numeric input 0**
Show a test pattern. Press again to show the next test pattern: *White, Black, Red, Green, Blue, Checkerboard, Crosshatch, V Burst, H Burst, Color Bar, Pluge, .*
The **SWAP** function is not used on this projector.
- 24. **COMP2 / PIP / numeric input 9**
There is no Component 2 input on this projector.
The **PIP** function is not used on this projector.

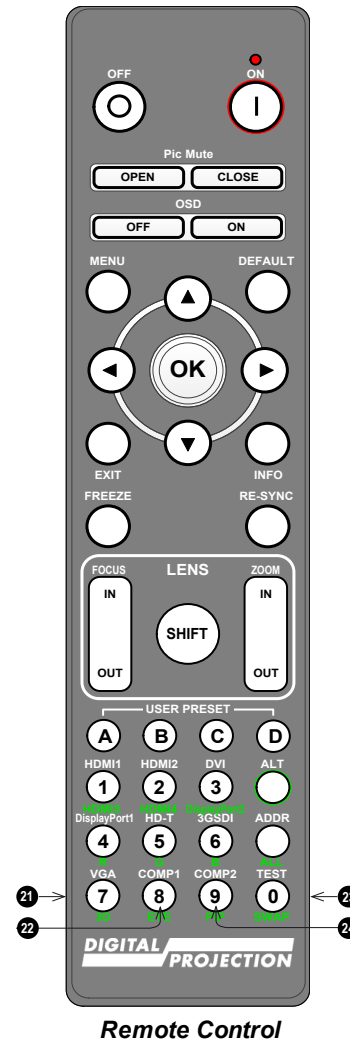

Notes

Infrared reception

The projector has infrared sensors at the front and rear.

The angle of acceptance is 40° . Make sure that the remote control is within the angle of acceptance when trying to control the projector.

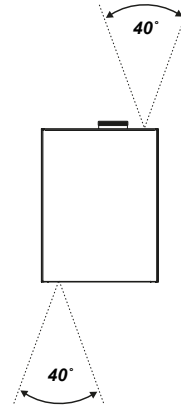

Notes

Module indicators

Satellite Head

1. **LASER ON**
 Off = laser is off
 On = laser is on

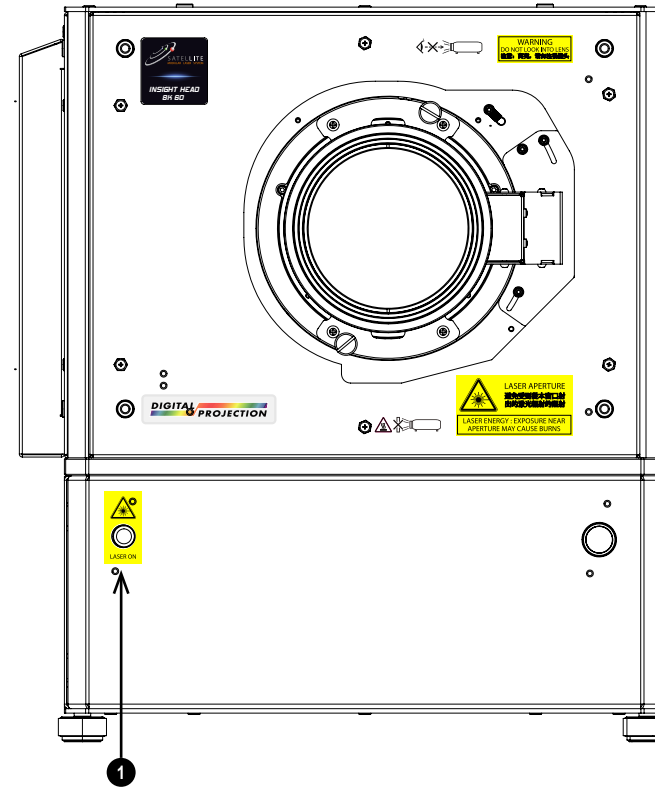

Satellite Head Front

Notes

The Laser ON indicator will light up for 30 seconds before the Laser turns on to warn that the laser is about to turn on.

Modular Light Source

MLS 10000

- LASER ON**
Off = laser is off
On = laser is on

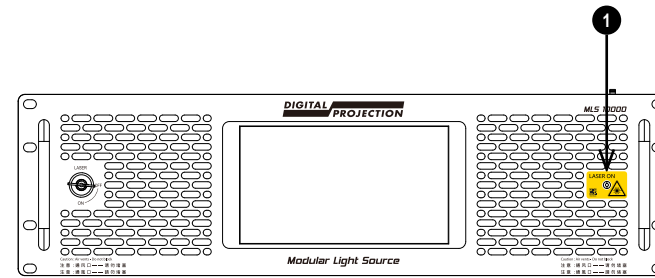

MLS 10000 Front

MLS 20000 / MLS 30000

- POWER**
Off = AC power is off
On = AC power is on
- LASER ON**
Off = laser is off
On = laser is on
- STATUS**
Off = no error
On = error, see LCD display for details.

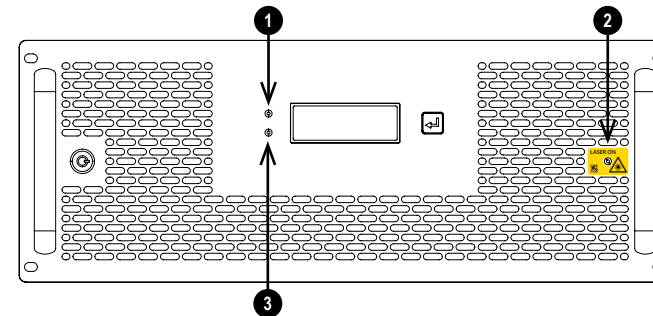

MLS 20000/MLS 30000 Front

Satellite Control Module

- LASER ON**
Off = laser is off
On = laser is on
- POWER GOOD**
Green = 12V power is good
Amber = 12V good, but internal power rail has a fault
Red = 12V PSU not operating within specifications
- INTERLOCK**
On = Laser system is active and interlock complete
Off = Laser system is not active

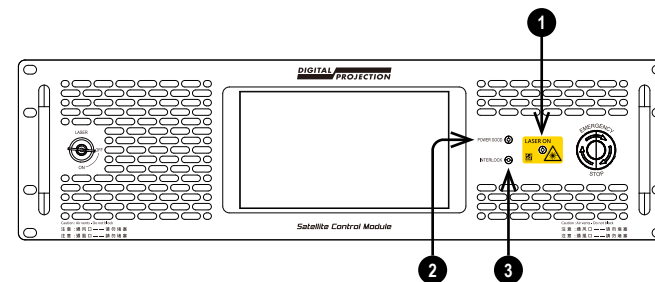

SCM Front

Notes

The Laser ON indicator will light up for 30 seconds before the Laser turns on to warn that the laser is about to turn on.

The Laser ON indicator will light up for 30 seconds before the Laser turns on to warn that the laser is about to turn on.

The Laser ON indicator will light up for 30 seconds before the Laser turns on to warn that the laser is about to turn on.

Satellite Insight 8K 60

Digital Video Projector
CONNECTION GUIDE



A brand of  **DELTA**

Signal inputs

Digital inputs and outputs

1. **HDMI A (Slot 1)**
HDMI 2.0 inputs supporting HDCP 2.2. Connect an **HDMI** cable to the connector.
HDMI A (Slot 2) is not used
2. **HDMI B (Slot 1)**
HDMI 2.0 inputs supporting HDCP 2.2. Connect an **HDMI** cable to the connector.
HDMI B (Slot 2) is not used
3. **Display Port A (Slot 1)**
Display Port 1.2 input. Connect a Display Port cable to the connector.
Display Port A (Slot 2) is only used for 8K alternate pixel packing when using 2D input signals.
4. **Display Port B (Slot 1)**
Display Port 1.2 input. Connect a Display Port cable to the connector.
Display Port B (Slot 2) is only used for 8K alternate pixel packing when using 2D input signals.

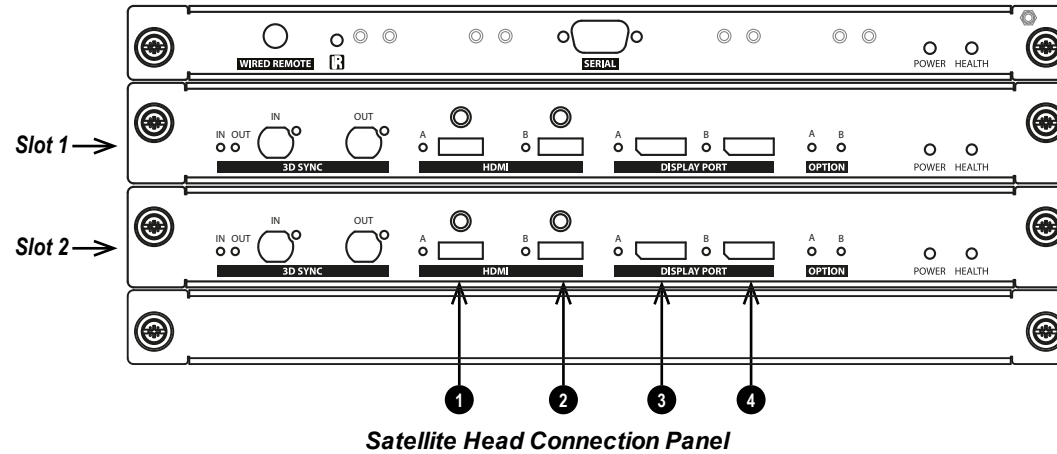

Satellite Head Connection Panel

Notes

- See 2D formats on page 170 for information about supported 2D signal input modes.
- See 3D connections on page 77 for information about 3D signal inputs.
- Do not use the HDMI and Display Ports on Slot 2 for 2D signal inputs.

EDID on the DisplayPort and HDMI inputs

If you are using a computer graphics card or another source that obeys the EDID protocol, the source will automatically configure itself to suit the capability of the projector.

Otherwise refer to the documentation supplied with the source to manually set the resolution to the DMD™ resolution of the projector or the nearest suitable setting. Switch off the source, connect to the projector, then switch the source back on again.

Using DisplayPort / HDMI switchers with the Satellite Head

When using a DisplayPort/HDMI source switcher with the projector, it is important to set the switcher so that it passes the projector EDID through to the source devices.

If this is not done, the projector may not be able to lock to the source or display the source correctly as its video output timings may not be compatible with those of the projector. Sometimes this is called transparent, pass-through or clone mode. See your switcher's manual for information on how to set this mode.

1. Sources
2. Switcher
3. Satellite Head

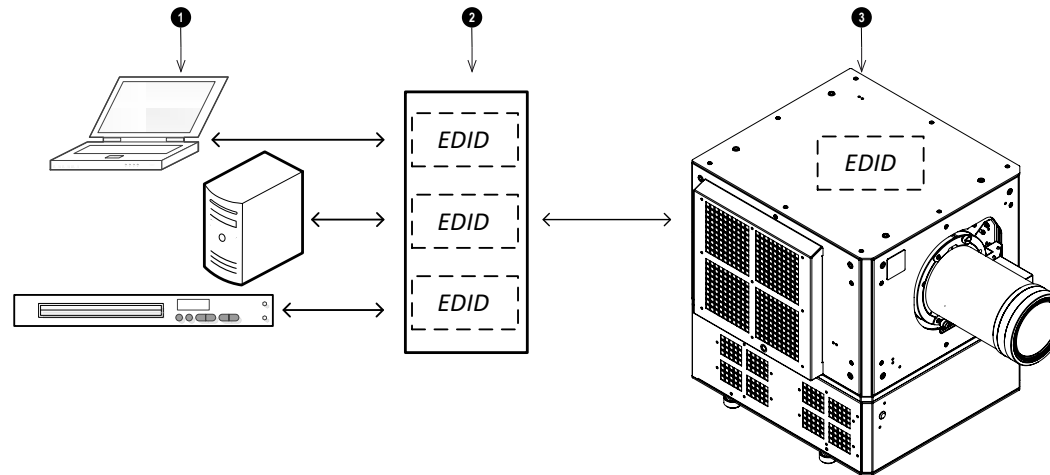

The EDIDs in the switcher should be the same as the one in the projector.

Notes



8K alternate pixel packing

8K input signals are processed using four 4K inputs from the signal source:

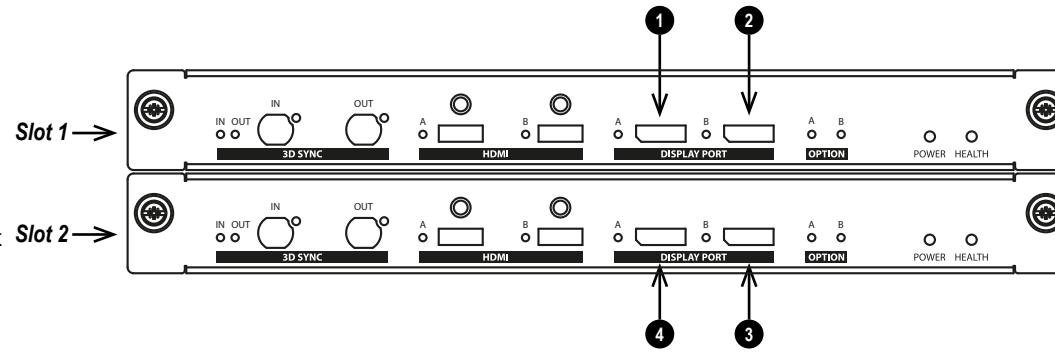
1. Connect the first 4K input to the Display Port A (Slot 1) socket **1**
2. Connect the second 4K input to the Display Port B (Slot 1) socket **2**
3. Connect the third 4K input to the Display Port B (Slot 2) socket **3**
4. Connect the fourth 4K input to the Display Port A (Slot 2) socket **4**
5. Use the touchscreen on the Satellite Head to set the **Display Port A+B+A+B 8K** multi input



Notes

-  See *Input* on page 109 for details on setting the multi input.
-  See *2D formats* on page 170 for information about supported 2D 8K formats.
-  See *How 8K is Processed* on page 174 for information about how 8K signals are processed.

3D connections

1. **Sync In (Slot 1)**
Only required for sequential 3D formats for eye dominance. Use a BNC connector to connect the 3D sync from your graphics card or server.
Sync In (Slot 2) is not used
2. **Sync Out (Slot 1)**
Provides synchronization signal for IR/RF Emitter, Z-Screen or other 3D Glasses sync device
Sync Out (Slot 2) is not used
3. **HDMI A (Slot 1)**
HDMI 2.0 inputs supporting HDCP 2.2. Connect an **HDMI** cable to the connector.
HDMI A (Slot 2) is not used
4. **HDMI B (Slot 1)**
HDMI 2.0 inputs supporting HDCP 2.2. Connect an **HDMI** cable to the connector.
HDMI B (Slot 2) is not used
5. **Display Port A (Slot 1), Display Port A (Slot 2)**
Display Port 1.2 input. Connect a Display Port cable to the connector.
6. **Display Port B (Slot 1), Display Port B (Slot 2)**
Display Port 1.2 input. Connect a Display Port cable to the connector.

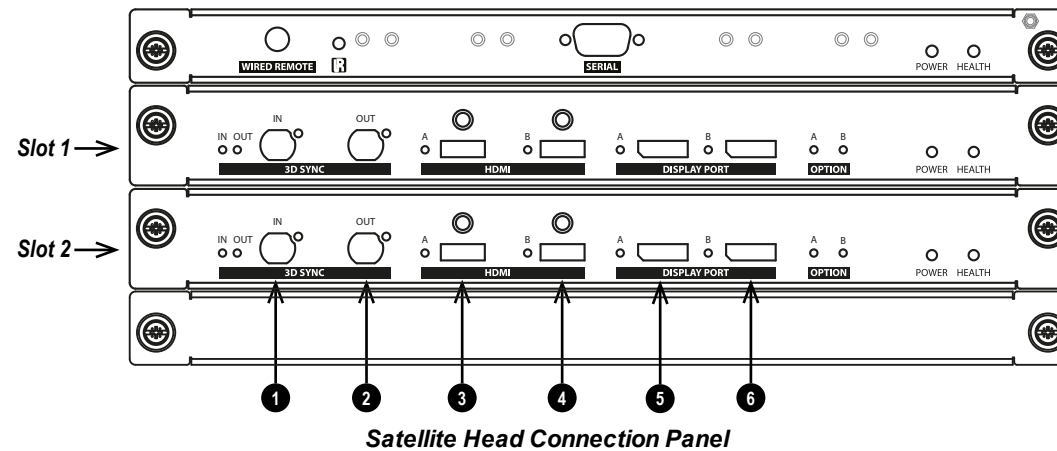

Notes

Set **3D Format** in the 3D menu to match the format of the incoming signal. See 3D on page 98.

See 3D formats on page 173 for information about supported 3D signal input modes.

3D frame packing, side-by-side and top and bottom formats

1. Connect to one of the following inputs on the connection panel:
 - HDMI A (Slot 1)
 - HDMI B (Slot 1)

Frame sequential

1. Connect to one of the following inputs on the connection panel:
 - HDMI A (Slot 1)
 - HDMI B (Slot 1)
 - DisplayPort A (Slot 1)
 - DisplayPort B (Slot 1)

Dual Pipe (Left/Right)

1. Connect the left eye output to the **DisplayPort A, Slot 1** socket and the right eye output to the **DisplayPort B, Slot 1** socket.
2. Set **Input** in the **Input** menu to **Dual Pipe Left/Right**.

Dual Pipe (East/West)

1. Connect the west output to the **DisplayPort A, Slot 1** socket and the west output to the **DisplayPort B, Slot 1** socket.
2. Set **Input** in the **Input** menu to **Dual Pipe East/West**.

3D Sync

1. 3D Sync In (Slot 1)
2. 3D Sync Out (Slot 1)
3. IR emitter or Z-Screen

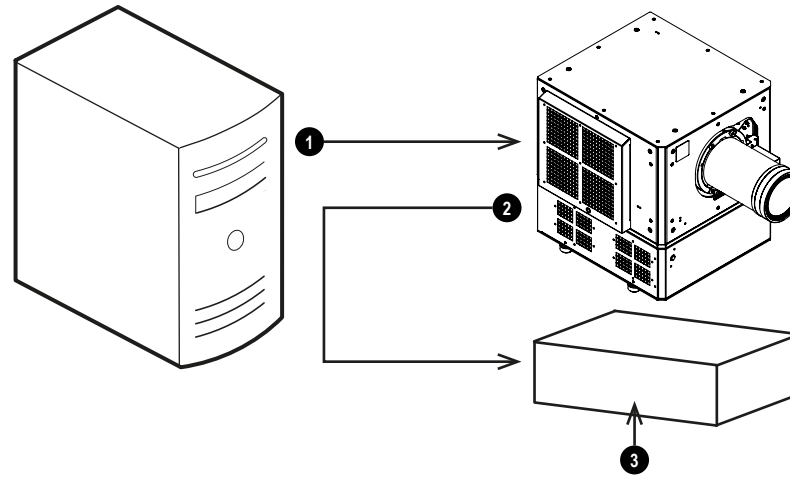



Notes

 See 3D formats on page 173 for information about supported 3D frame packing, side-by-side and top and bottom formats.

 See 3D formats on page 173 for information about supported 3D frame sequential formats.

 See 3D formats on page 173 for information about supported 3D dual pipe formats.

 See 3D formats on page 173 for information about supported 3D dual pipe formats.

 See 3D formats on page 173 for information about supported 3D sync formats.



3D Multiview

3D Multiview allows up to two 3D Dual Pipe image views to be projected from the Satellite Head. When viewed through 3D glasses, the viewer will only see the images that their glasses are synchronized with.

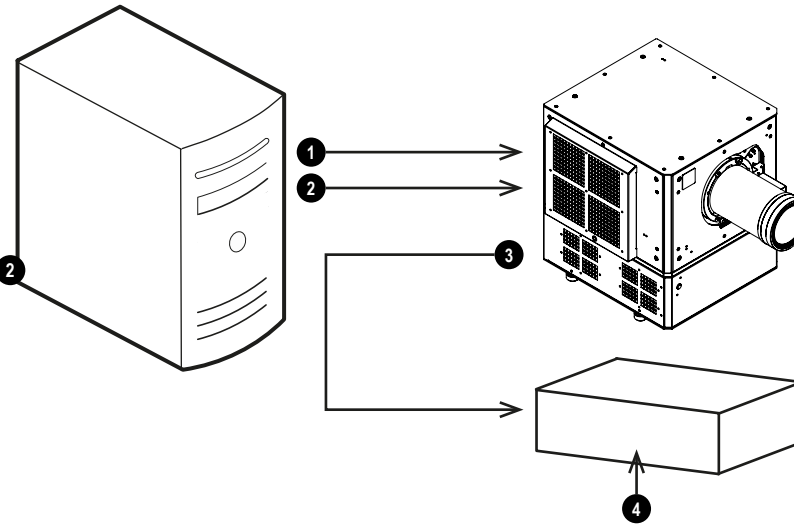
1. Connect the signal inputs for the first image view **1**:
 - DisplayPort A, Slot 1 (Dual Pipe Left)
 - DisplayPort B, Slot 1 (Dual Pipe Right)
2. Connect the signal inputs for the second image view **2**:
 - DisplayPort A, Slot 2 (Dual Pipe Left)
 - DisplayPort B, Slot 2 (Dual Pipe Right)
3. Connect the 3D Sync Out from the projector **3** to the IR emitter or Z-Screen **4**
4. Set **Input** in the **Input** menu to **Dual Pipe Left/Right**.



Notes

-  See 3D formats on page 173 for information about supported 3D multiview formats.
-  Make sure that the first multiview input source is connected to the appropriate inputs on slot 1.

Control connections

1. **Wired Remote**
The remote control can be connected using a standard 3.5 mm mini jack cable (tip-ring-sleeve, or TRS).
2. **RS232**
This port is for servicing purposes only.
3. **Ethernet**
This system can be controlled via an Ethernet connection. Use an Ethernet cable to connect the SCM to your computer.

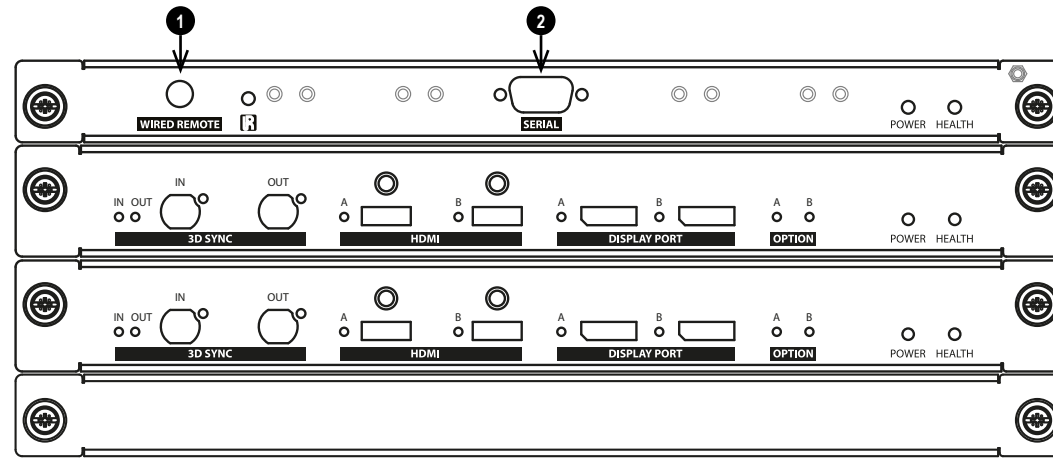

Satellite Head Connection Panel

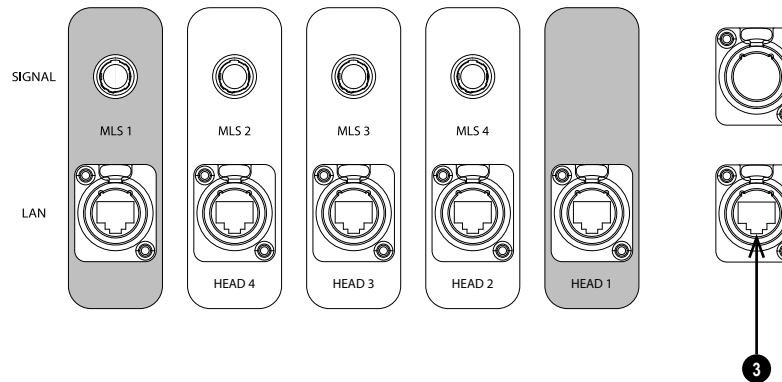

SCM Connection Panel

Notes

See "Connecting the Signal and LAN cables" on page 50 and "Connecting the Satellite Link Cable" on page 47 for guidance on setting up the connections between each Satellite Head, MLS and SCM.

For a list of all commands used to control the projector via LAN, see the **Protocol Guide** (available separately).

Only one control connection should be used at any one time.

With an Ethernet connection the system can serve a web page offering status and controls. See Served web pages on page 179 for guidance on accessing and using the served web pages.

Projector Controller is available for download, free of charge, from the Digital Projection website.

LAN connection examples

The projector's features can be controlled via a LAN connection, using Digital Projection's **Projector Controller** application or a terminal emulation program.

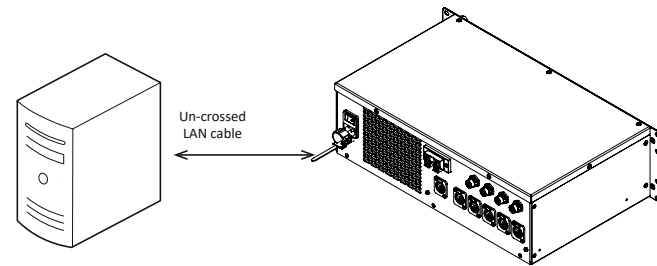

Notes

With an Ethernet connection the system can serve a web page offering status and controls. See Served web pages on page 179 for guidance on accessing and using the served web pages.

***Projector Controller** is available for download, free of charge, from the Digital Projection website.*

Indicators on the connection panel

1. **IR**
2. **Power**
This lights a solid green color if the projector is switched on.
3. **Health**
This flashes amber, then green, during boot up. When the projector is switched on and fully functional, this lights solid green.
4. **3D Sync In / Out 1 (Slot 1)**
These light solid green if 3D sync is present.
5. **HDMI A (Slot 1), HDMI A (Slot 2)**
This lights a solid green color if the input is in use. If the input is selected but the source is not present, it flashes green.
6. **HDMI B (Slot 1), HDMI B (Slot 2)**
This lights a solid green color if the input is in use. If the input is selected but the source is not present, it flashes green.
7. **Display Port A (Slot 1), Display Port A (Slot 2)**
This lights a solid green color if the input is in use. If the input is selected but the source is not present, it flashes green.
8. **Display Port B (Slot 1), Display Port B (Slot 2)**
This lights a solid green color if the input is in use. If the input is selected but the source is not present, it flashes green.
9. **Option A**
This is not used.
10. **Option B**
This is not used.
11. **Power**
This lights a solid green color if the projector is switched on.
12. **Health**
This flashes amber, then green, during boot up. When the projector is switched on and fully functional, this lights solid green.

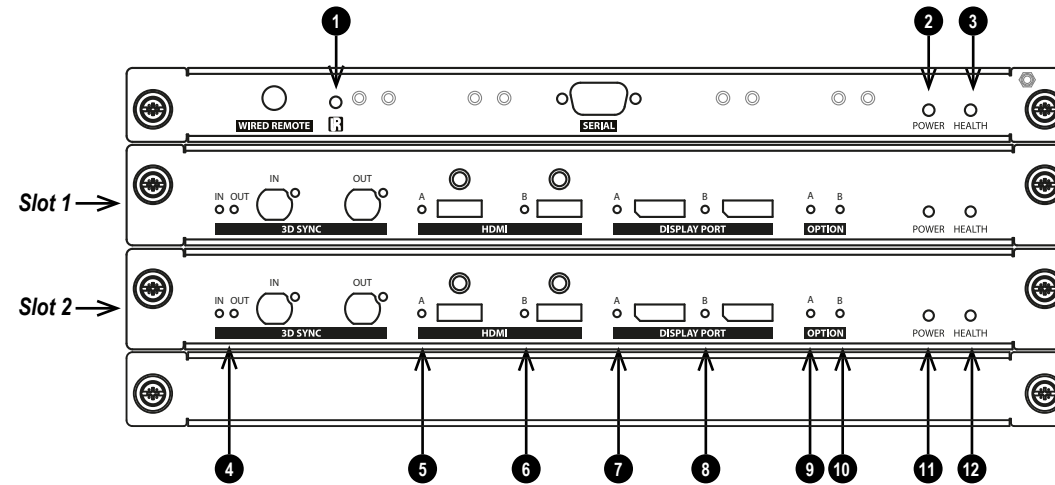

Notes

Satellite Insight 8K 60

Digital Video Projector

ON SCREEN DISPLAY (OSD) OPERATING GUIDE



A brand of  **DELTA**

Introduction to the OSD

This section describes the operation of the OSD.

Opening the Menu

Use the remote control to open the on-screen display (OSD):

1. Press the **MENU** button.
The OSD opens showing the list of available menus

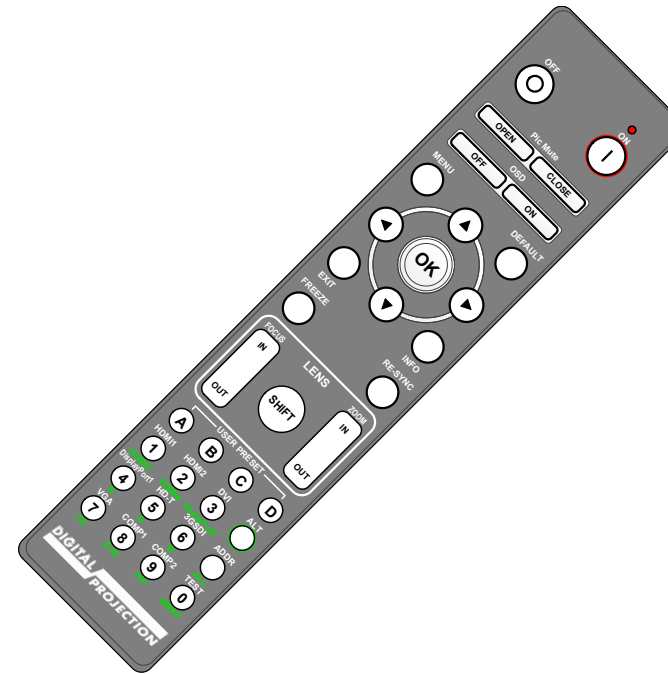

Remote control

Notes

Opening a submenu

1. Move up and down the list using the **UP** and **DOWN** arrow buttons.
2. Press **OK** on to open a submenu.

Exiting menus and closing the OSD

To go back to the previous page:

1. Press **EXIT**.

To close the OSD:

1. Press **MENU**.

Or:

1. Go back to the top level menu
2. Press **EXIT**.

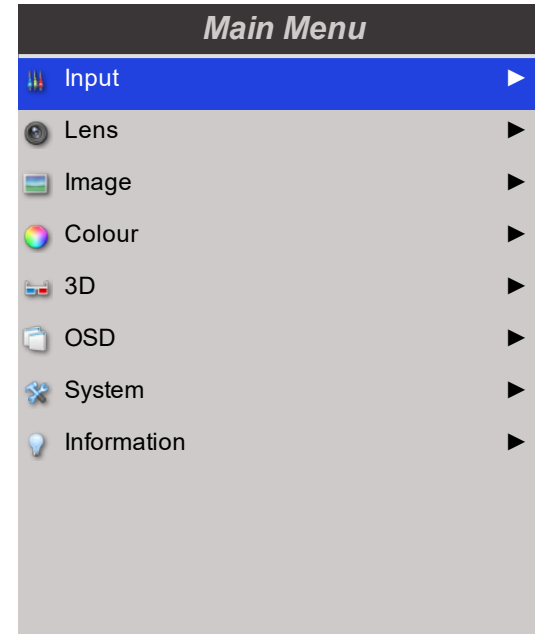

On Screen Display (OSD): Top Level Menu

Notes

Inside a menu

When you open a menu, the page consists of the following elements:

- Title bar at the top shows which menu you have accessed.
- Highlighted item
- Available and unavailable items Unavailable items appear a pale gray color. Whether an item is available may depend on other settings.
- The text or symbol to the right of an item shows whether the item:
 - has a value that can be changed (the current value is shown)
 - opens a sub-menu (an arrow button is displayed)
 - executes a command (the space to the right of the item is blank).

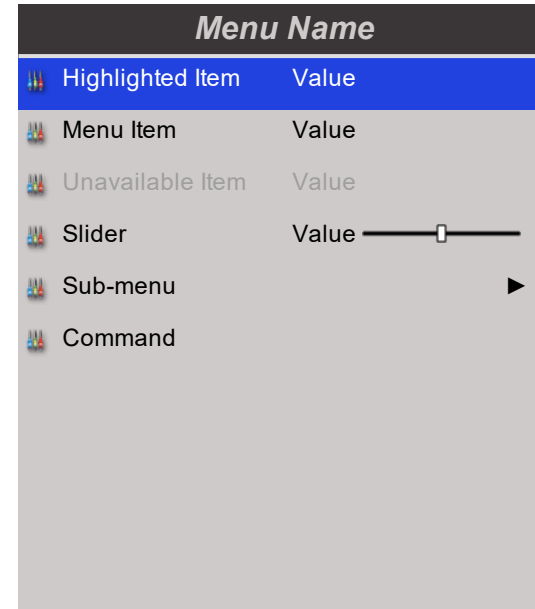

Inside a menu

Notes

Accessing sub menus

Use the **UP** and **DOWN** arrow buttons to highlight the sub-menu, then press **ENTER/OK**.

Executing commands

Some items contain a command, such as an OK button.

Press **ENTER/OK** to execute the highlighted command.

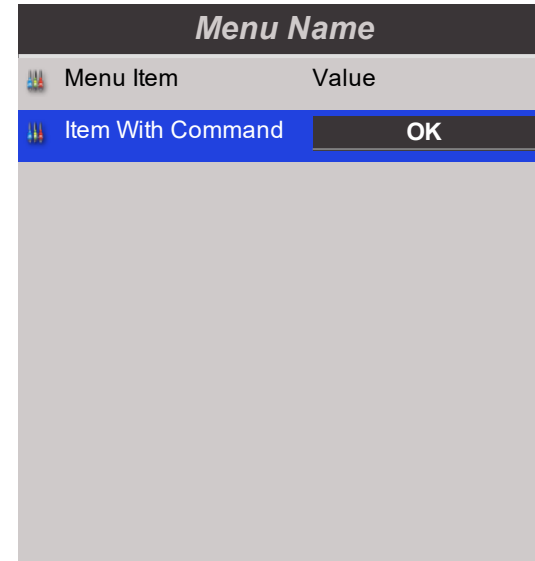

Command

Editing projector settings

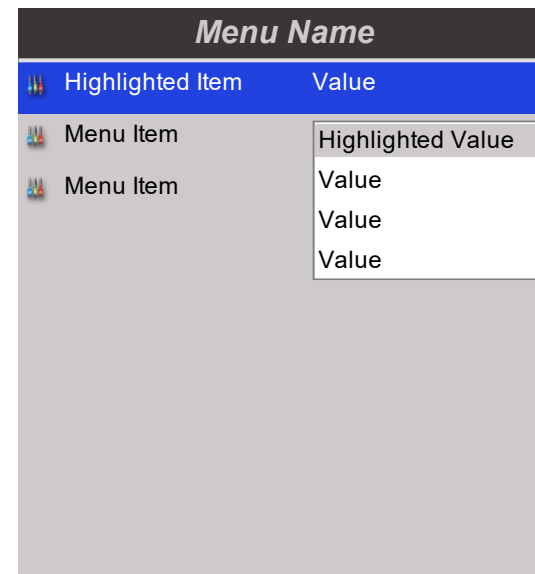

If the highlighted menu item contains a list of values to choose from, you can change the value by doing the following:

1. Highlight the menu item and press **ENTER/OK**.
2. In the list of values that opens, use the **UP** and **DOWN** arrow buttons to highlight a value, then press **ENTER/OK** again to select the highlighted value.



List of Values

Notes

-  Some menu items may be unavailable due to settings in other menus. Unavailable menu items appear gray
-  Please wait for any value changes to be applied

Using a slider to set a value

Some parameters show a slider. To set such a parameter:

1. Press the **LEFT** or **RIGHT** arrow button, or **ENTER/OK**. The arrow buttons will open the slider and adjust the value at the same time. **ENTER/OK** will open the slider without altering the initial value.
2. Use the **LEFT** and **RIGHT** arrow buttons to move the slider.
3. When ready, press **RETURN** to exit the slider and return to the menu.

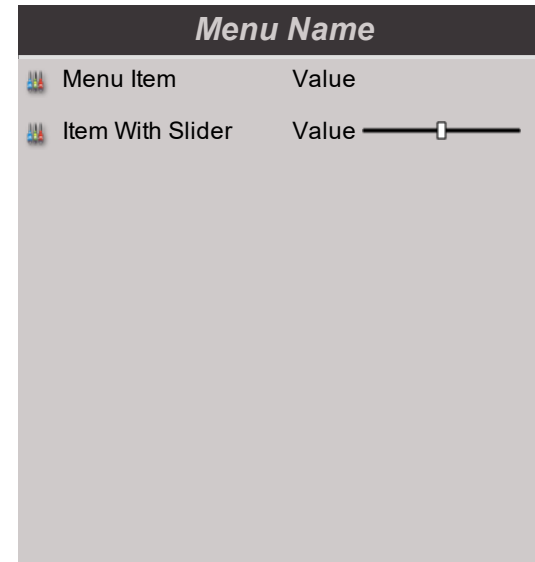

Slider

Editing numeric values

Some parameters take numeric values without using sliders - for example, color matching values or IP addresses.

1. Use the **UP** and **DOWN** arrow buttons to highlight the row containing the numeric field you wish to edit.
2. Press **ENTER/OK** to enter edit mode. A numeric field in edit mode is white text on blue background.
3. In edit mode:
 - Use the **UP** arrow button to increase the numeric value.
 - Use the **DOWN** arrow button to decrease the numeric value.
4. Use the **LEFT** and **RIGHT** arrow buttons to edit the next or previous numeric fields within the same row.
5. Once ready, press **ENTER/OK** to exit edit mode.

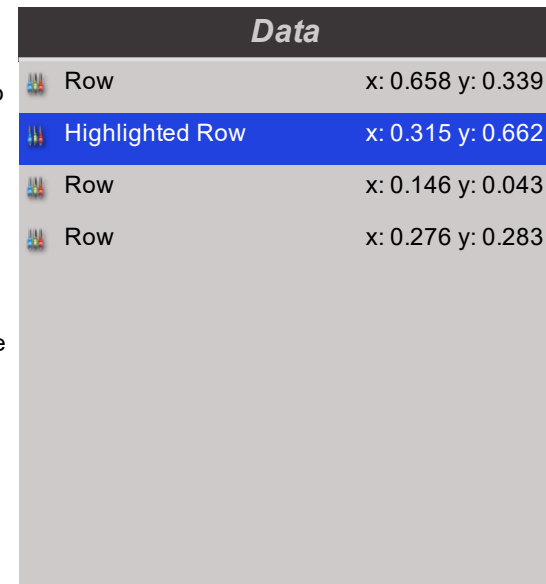

Notes

Using the projector

Main Menu

- **Input, Lens, Image, Colour, 3D, OSD, System, Information.**
Tap to open these menus and access various settings.

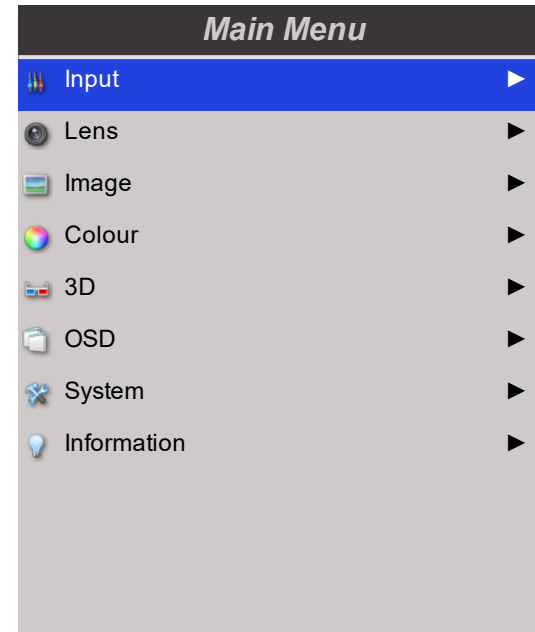

On Screen Display (OSD): Top Level Menu

Notes

Input

- **Input**

Press **ENTER/OK** to open the list of available inputs. Use the **UP** and **DOWN** arrow buttons to select an input from the list, then press **ENTER/OK** to confirm your choice. Press **EXIT** to return to the main menu. Choose from:

- 2D sources (Slot 1):
 - HDMI A
 - HDMI B
 - Display Port A
 - Display Port B
- 3D sources:
 - DisplayPort A+B L/R
 - DisplayPort A+B EW
- **Resync**
Access the sub menu to use this feature. See Resync on the facing page
- **Test Pattern**
Select a Test Pattern to display. The Test Pattern will be displayed instead of any other image from an input source. Choose from Off, ANSI Chequerboard, Colour Bars, Alignment, Native White, Native Black, Native Red, Native Green and Native Blue.
- Input Format
Information only
- **Main Menu**

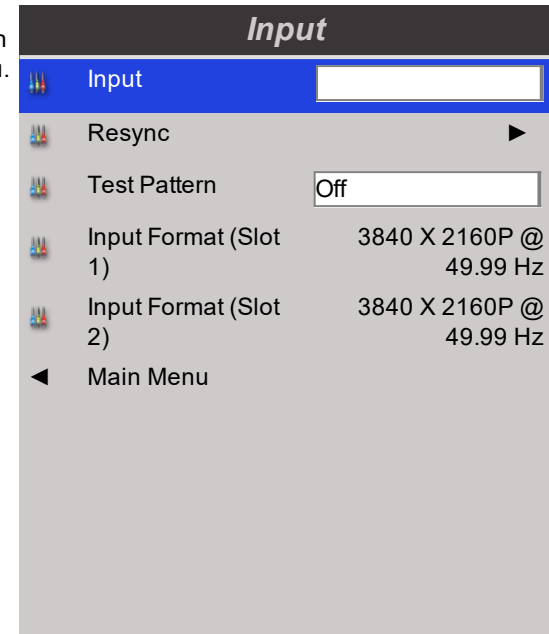

Notes

See *Digital inputs and outputs* on page 74 and *See 3D connections* on page 77 for guidance on how to connect an input source. See *8K alternate pixel packing* on page 76 for guidance on how to connect an 8K input source.

See *Set Multi Input* on page 110 for using the *Touchscreen* to set the input source for 8K processing.

Resync

Use this feature to re-acquire an incoming signal on a DisplayPort input. Select OK to re-acquire the incoming signal on the highlighted Display port.

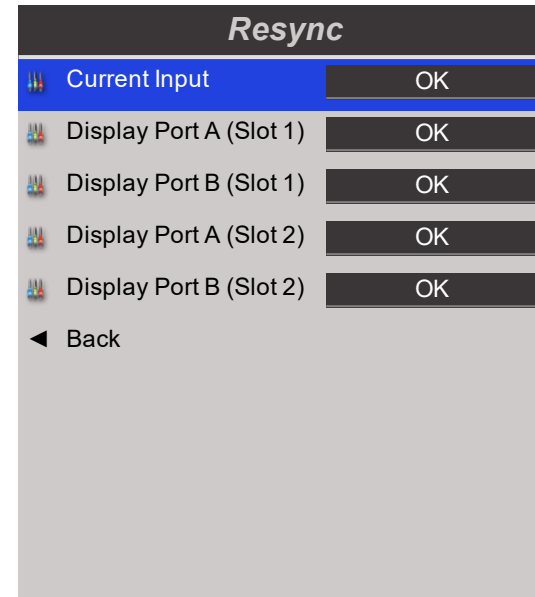
**Notes**

Lens

- **Lens Calibrate**
Access the sub menu to use this feature. See Lens Calibrate on the facing page
- **Lens Presets**
Access the sub menu to use this feature. See Lens Presets on the facing page
- **Lens Shift Orientation Lock**
Tick to lock lens calibration.
- **Focus Nudge Amount**
Adjust the nudge amount as required. Sets the focus adjustment when the Nudge Near or Nudge Far option is used in the Lens Focus menu.
- **Zoom Nudge Amount**
Adjust the nudge amount as required. Sets the zoom adjustment when the Nudge In or Nudge Out option is used in the Lens Zoom menu.
- **Back**
Select this to return to the Lens Menu.

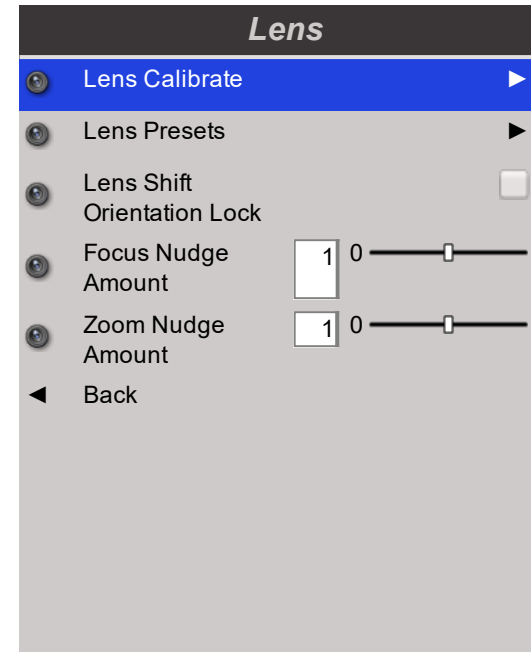

Notes

Lens Calibrate

- Focus**
 Select **OK** to calibrate the focus range of the lens. This establishes minimum and maximum travel distances for the focus control. Allow at least 60 seconds for the calibration to take place.
- Zoom**
 Select **OK** to calibrate the zoom range of the lens. This establishes minimum and maximum travel distances for the zoom control. Allow at least 60 seconds for the calibration to take place.
- Centre**
 Select **OK** to calibrate the center point for the lens. This establishes a center point in relation to the zoom and focus controls. Allow at least 60 seconds for the calibration to take place.
- Back**
 Select this to return to the Lens Menu.

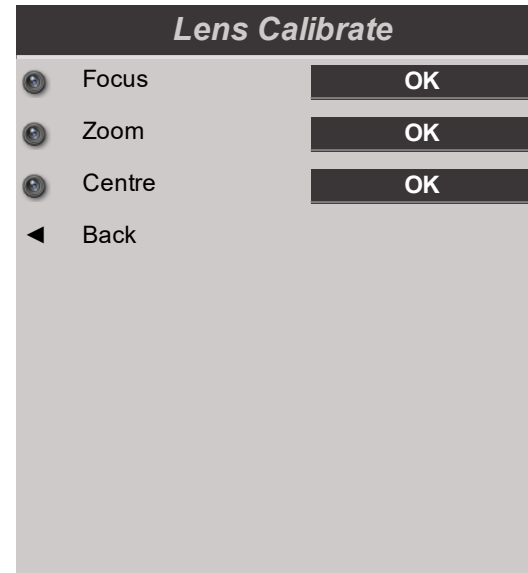

Notes

When a new lens is fitted into the projector, it must be calibrated. It is recommended that you calibrate the focus before calibrating the zoom.

See Satellite Head Control panel on page 65 for guidance on calibrating the lens using the control panel.

See Remote control on page 66 for guidance on calibrating the lens using the remote control.

Lens Presets

- Recall Preset 1, Recall Preset 2, Recall Preset 3, Recall Preset 4**
 Select **OK** to load the position, zoom, focus and shift adjustment information that has been stored for the preset.
- Lens Presets Store**
 Access the sub menu to use this feature. See Lens Presets Store on the next page
- Back**
 Tap to return to the Lens Menu.

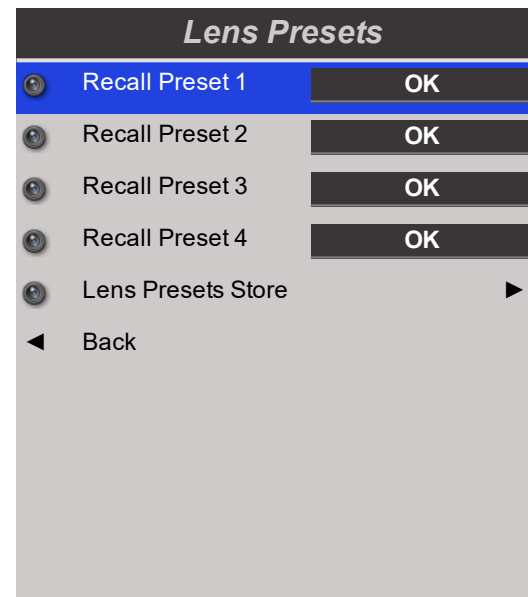

Lens Presets Store

- **Store Preset 1, Store Preset 2, Store Preset 3, Store Preset 4**
Select **OK** to store the position, zoom, focus and shift adjustment information as a preset.
- **Back**
Tap to return to the Lens Presets Menu.

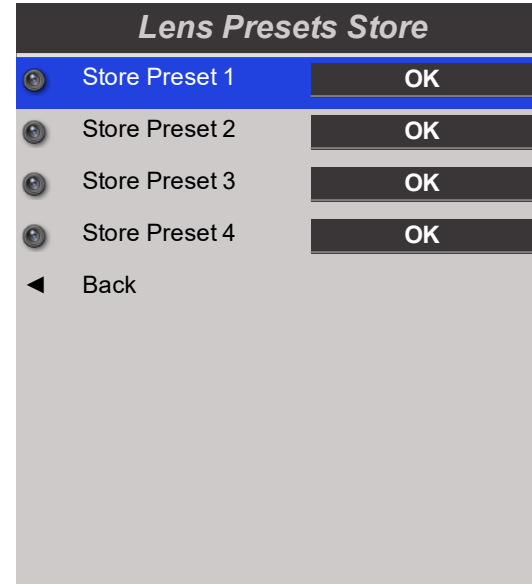

Notes

Image

- **Brightness**
Adjust the brightness level of the projected image as required.
- **Contrast**
Adjust the contrast of the projected image as required.
- **Gamma**
Adjust the gamma of the projected image as required.
Used correctly, the **Gamma** setting can improve contrast while maintaining good details for blacks and whites.
If excess ambient light washes out the image and it is difficult to see details in dark areas, lower the **Gamma** setting to compensate. This improves contrast while maintaining good details for blacks. Conversely, if the image is washed out and unnatural, with excessive detail in black areas, increase the setting.
- **Geometry**
Access the sub menu to use this feature. See Geometry on the next page
- **Main Menu**
Go back to the main menu.

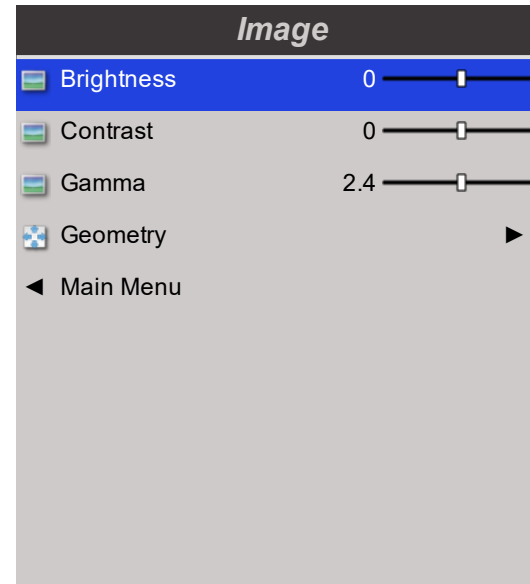

Notes

Geometry

- **Scaler Enabled**
Tick to enable image scaling. Sources with a height of 1080 pixels or less may be doubled in height, and sources with 2048 pixels in width may be doubled in width. Should doubling cause the image to exceed either 2160 pixels in height or 4096 pixels in width the scaling will not occur, and the image will be displayed as delivered and centered.
- **Orientation**
Select the display orientation. Choose from Desktop Front, Ceiling Front, Desktop Rear, Ceiling Rear.
- **Back**
Go back to the Image menu.

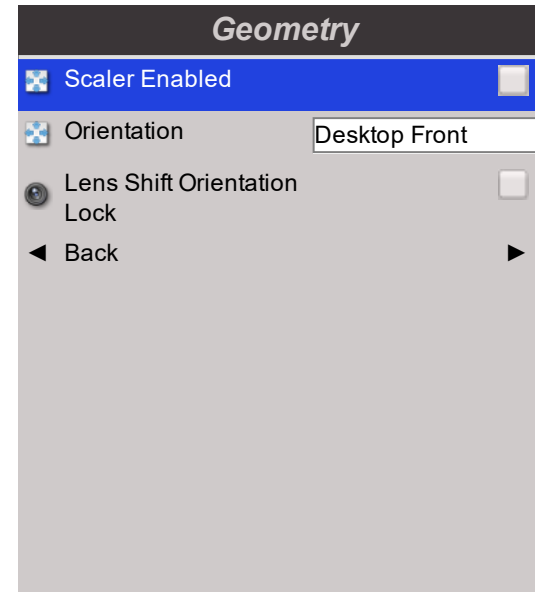

Notes

Colour

- **Red Lift**, Green Lift, Blue Lift
Adjust the black levels of each color on the projected image as required.
- **Red Gain**, Green Gain, Blue Gain
Adjust the bright part of each color on the projected image as required.
- **Colour Space**
Select the color space, as required. Choose from Auto, RGB, YUV SD, YUV HD.
- **Colour Preset**
Select the color preset, as required. This adjusts the compression of the colors used in the projected image. Choose from User, Peak, REC709, REC601, 3200 K, 5400 K, 6500 K, 8000 K, 9000 k, Extended, Ultra.
- **Colour Sampling**
Select the color sampling, as required. This adjusts the compression of the colors used in the projected image. Choose from Auto, 4:4:4, 4:4:2, 4:2:0.
- **Back**
Go back to the Main menu.

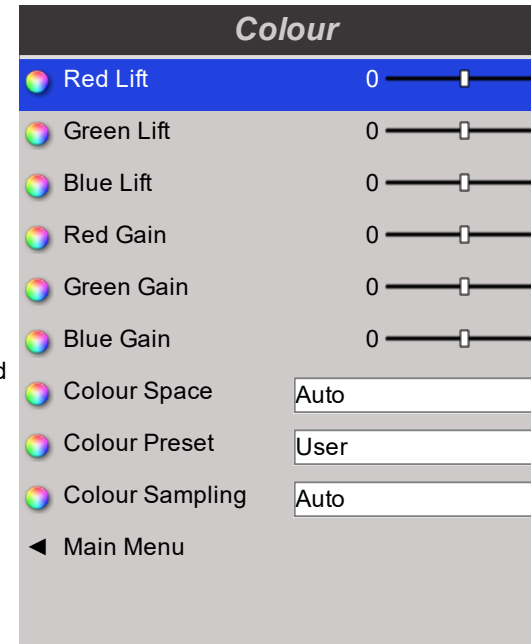

Notes

3D

Use this menu to enable, disable and set up 3D input, as follows:

- **3D Enabled**
Tick to enable 3D.
- **Format**
Select the format as required. Choose from **Auto**, **Sequential**, **Frame Packing**, **Side-by-Side**. **Sequential** is for sources where Left and Right eye images are delivered as alternate frames from a single input.
- **Dominance**
Select the eye dominance when the format is set to sequential. Choose from **Left** or **Right**.
- **Dark Time**
Select the dark time rate, as required. Choose from **Off**, **250 µs**, **500 µs**, **1000 µs**, **1500 µs**, **7000 µs**.
- **Sync In Enable**
Tick to enable 3D Sync In.
- **Sync In Polarity**
Select the 3D Sync In Polarity when Sync In is enabled. Choose from **Positive** or **Negative**.
- **Sync Out Enable**
Tick to enable 3D Sync Out.
- **Sync Out Polarity**
Select the 3D Sync In Polarity when Sync In is enabled. Choose from **Positive** or **Negative**.
- **Sync Out Offset**
Adjust to compensate for image overlapping (ghosting) when viewed through 3D glasses.
- **Main Menu**
Go back to the main menu.

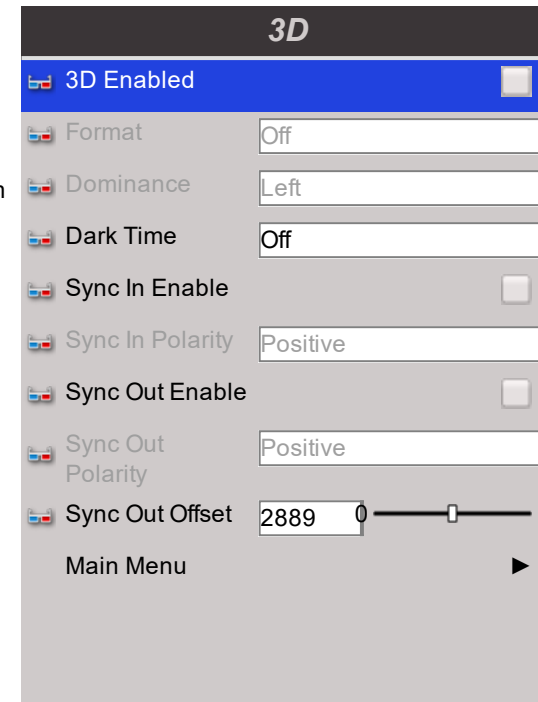

Notes



A frame rate multiplier is available via the projector controller application



Dark Time is only applied if it is applicable to the source frame rate.



See 3D types on the facing page for more information about 3D settings.

3D types

To display a 3D image it is first necessary to select the 3D format of the source:

- **Sequential**

For sequential 3D, an external sync is required to identify left and right frames. If no sync is available from the sequential source, the projector will generate an output sync, but it may then be necessary to manually set the Eye Swap each time the player is started.

- **Dual Pipe (LEFT and RIGHT)**

The left and right eye images are delivered on two separate inputs, which the projector will interleave for 3D display. The left input delivers all images for the left eye, the right input delivers all images for the right eye.

- **Dual Pipe (EAST and WEST)**

The left and right eye images are delivered on two separate inputs, which the projector will interleave for 3D display. The west input delivers left and right images for the left half of the image, the east input delivers the left and right images for the right half of the image.

- **Side-By-Side**

- **Top/Bottom**

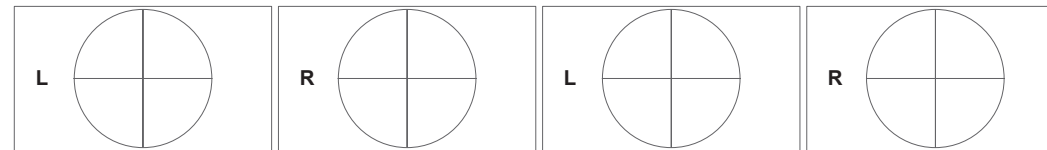

Sequential

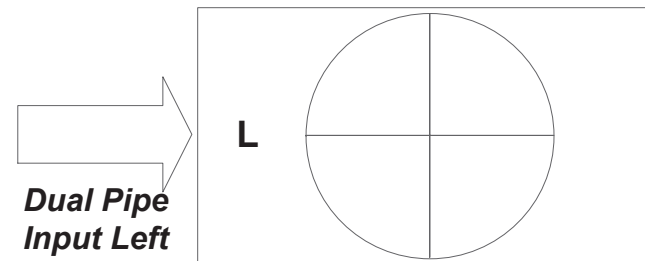

**Dual Pipe
Input Left**

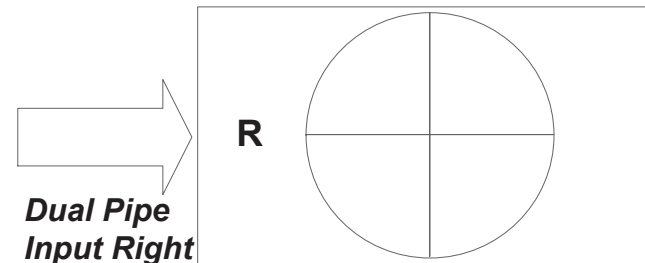

**Dual Pipe
Input Right**

Dual Pipe Left/Right

Notes



See 3D connections on page 77 for guidance on the 3D input connections.

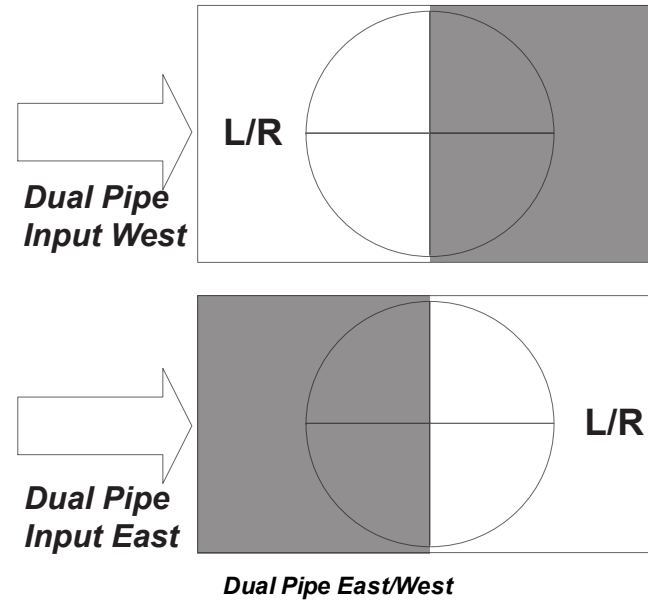

Notes

Some 3D settings explained

Dark Time

Banding can be caused if the image is displayed before each eye of the 3D switching glasses or ZScreen is not fully open. **Dark Time** allows you to minimize this effect.

The outgoing 3D frames are in pairs - the dominant frame being presented first. You can determine which frame should be the dominant one.

By convention the default setting is **Left**.

The sync signal from the 3D server will be in phase with the frames generated by its graphics card.

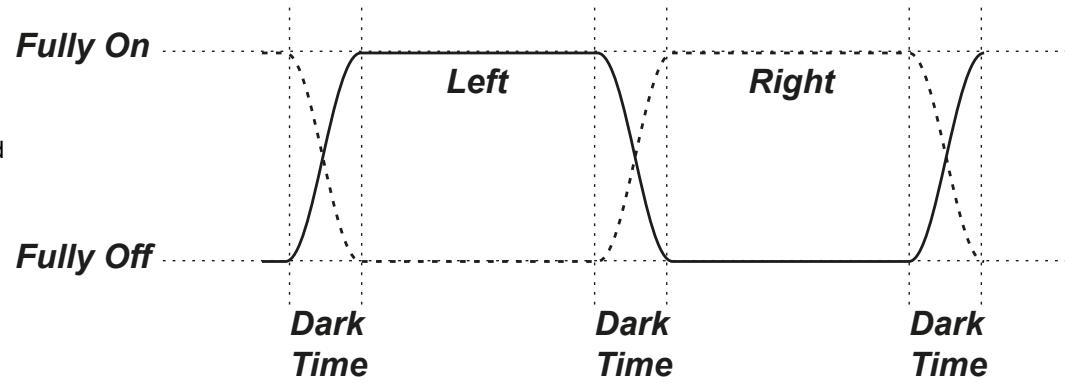

Dominance Left



Dominance Right

Notes

In order to achieve maximum light output and a smooth grayscale, whilst eliminating ghosting, the following procedure is recommended:

1. Set **Dark Time** to a value appropriate to the glasses or ZScreen, say 1.3 ms or 1.95 ms.
2. Adjust time to eliminate ghosting and achieve a smooth grayscale.
3. Repeat steps 1 and 2 until the best result is obtained.

OSD

- **Timeout (secs)**
Choose how long the OSD should remain on screen if no buttons are pressed.
- **Confirmation Prompts**
Enable this to require a confirmation when a command is used in the OSD.
- **Source Change**
Enable this to display a message when the source input is changed.
- **Zoom**
Enable this to double the size of the OSD.
- **Main Menu**
Go back to the main menu.

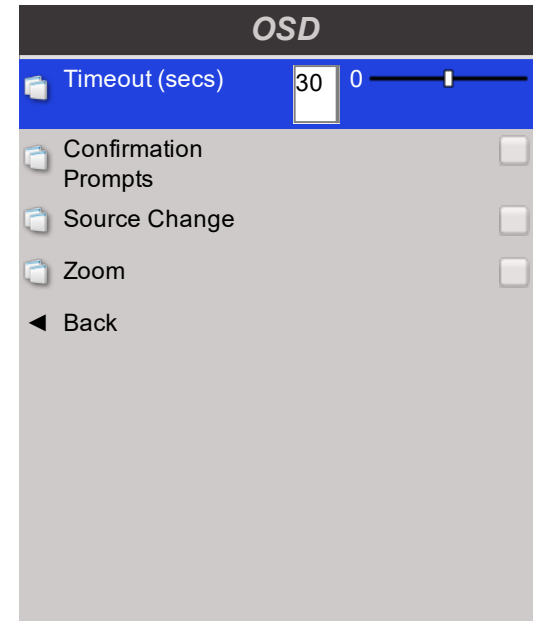

Notes

System

- **High Altitude**
Tick to activate High Altitude mode.
- **Factory Reset**
Tap **OK** to restore the default factory settings.
- **Auto Standby**
Tick to enable auto standby mode.
When enabled, the system will activate the standby mode if no signal is detected for the duration of the standby timeout timer.
- **Standby Timeout (mins)**
Adjust to set the standby timeout timer.
- **Main Menu**
Go back to the main menu.

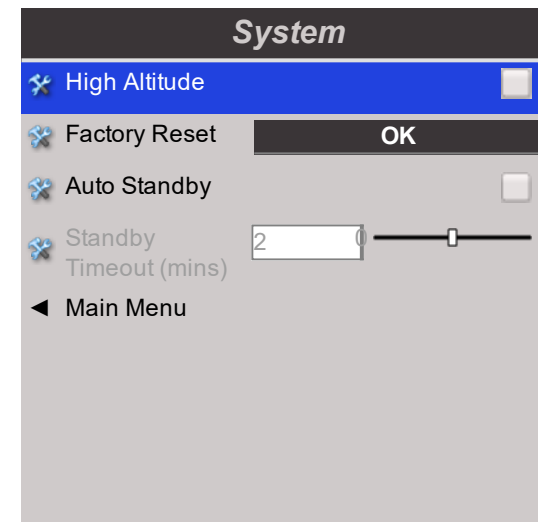

Information

Each submenu in this menu provides information about this system.

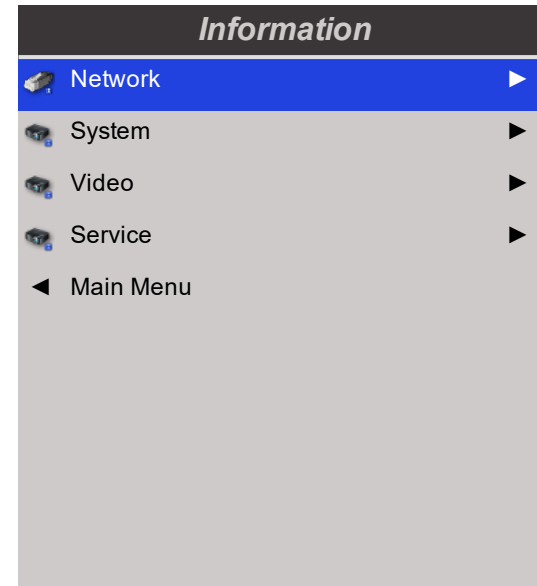

Network

Information Only

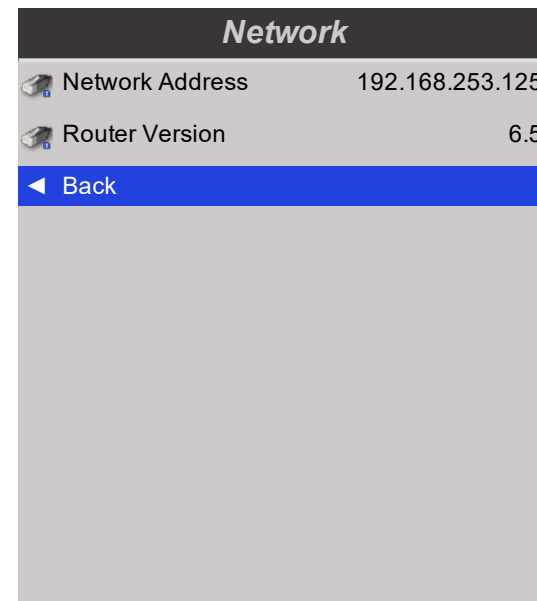

Notes

System

Information Only

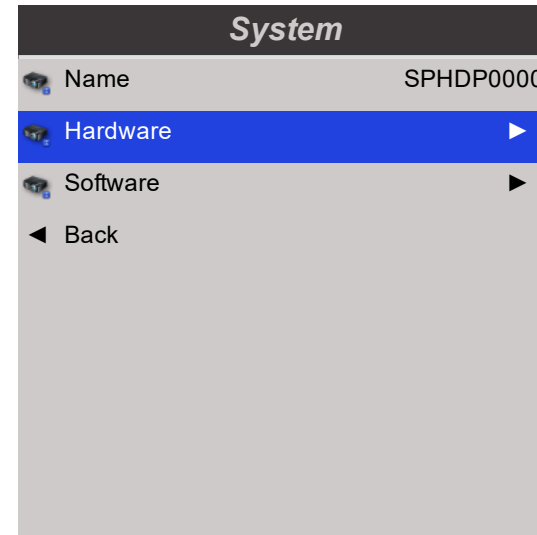

Notes



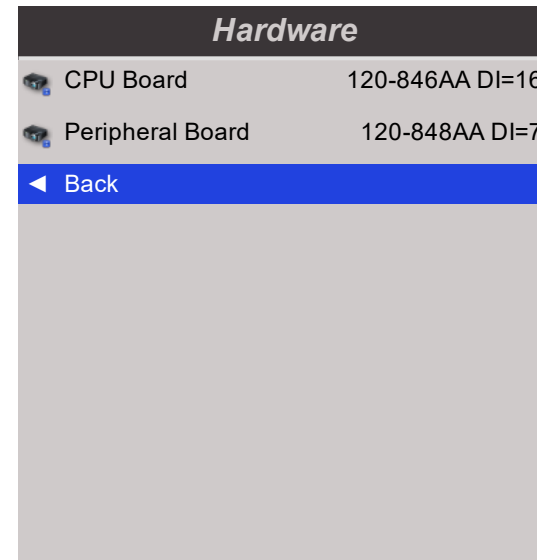

Hardware

Information Only







Software

Information Only

<i>Software</i>		
 Control Software		Version 00.05
 User Interface		4.0.341-Dev
 Firmware		1.0R build 78
 Lens Mount		MM-D04
 Factory ROM		4
◀ Back		

Video

Information Only



<i>Video</i>		
 Video Software		09.6(1)
 Video Board ID		E (A0)
 Input Format		3840 x 2160p @49.99 Hz
 Input Line Rate		112.477 kHz
 Input Status		2.2,
◀ Back		

Notes

Service

Information Only

Service

 CPU Board Status	SPHDP0000
 Peripheral Board Status	SPHDP0000
 UDP Logs	VIEW

◀ Back

Notes

Satellite Insight 8K 60

Digital Video Projector

SATELLITE HEAD TOUCHSCREEN OPERATING GUIDE



A brand of  **DELTA**

Introduction to the Satellite Head Touchscreen

This section describes the operation of the Satellite Head touchscreen control panel. Please refer to the page 13 for guidance on installing the Satellite Head as part of the Satellite system. See Using the menus on page 1 for guidance on using the OSD.

Using the menus

The Satellite Head displays a touch screen menu when the power is on.

When you open a menu, the page consists of the following elements:

- Title bar at the top shows which menu you have accessed. Additional buttons are available in the title bar:
 - tap the refresh button to refresh the information on the screen
 - tap the home button to return to the main menu
- Available and unavailable items Unavailable items appear a pale gray color. Whether an item is available may depend on other settings.
- The text or symbol to the right of an item shows whether the item:
 - has information only
 - has a value that can be selected. The current selection is displayed in a box. Tap to select a new option
 - has a tick box. A tick indicates that the feature is enabled. Tap to enable or disable the feature
 - has a slider. A box displays the current value of the setting. Press and drag the slider to adjust the value
 - opens a sub-menu. Tap the arrow button to open the sub menu
 - executes a command. Tap the command button to execute.

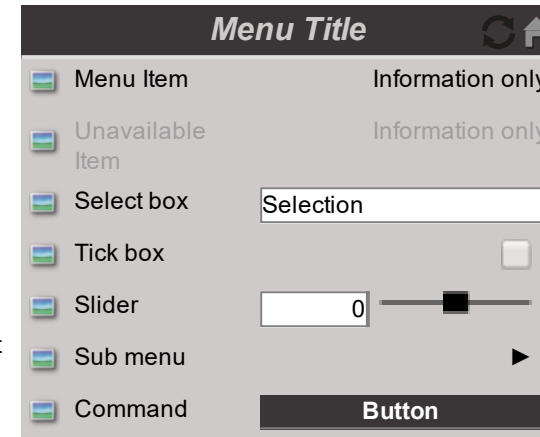

Inside a Menu

Notes

Main Menu

- **Input, Lens, Image, 3D, System, Information.**
Tap to open these menus and access various settings.

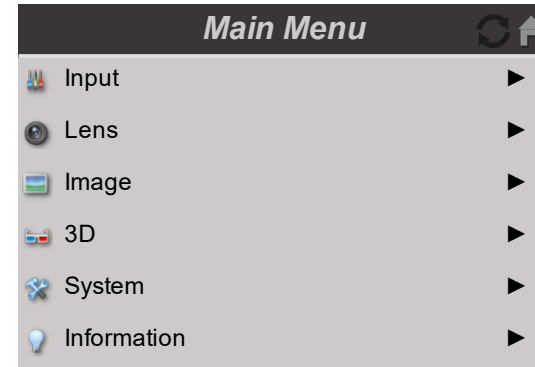

Touchscreen Display: Top Level Menu

Input

- **Current Input**
Information only
- **Set Input**
Access the sub menu to use this feature. See Set Input on the next page
- **Resync**
Access the sub menu to use this feature. See Resync on page 111
- **Test Pattern**
Access the sub menu to use this feature. See Test Patterns on page 111
- **Input Format**
Information only
- **Main Menu**

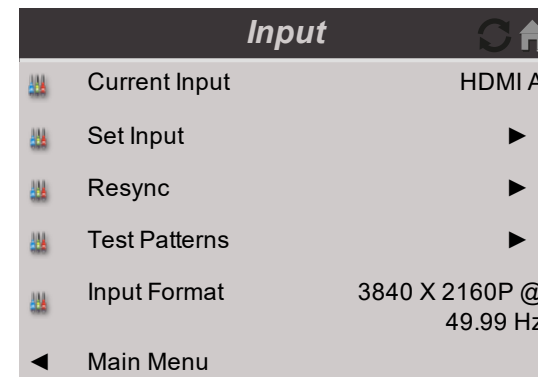

Notes

See Digital inputs and outputs on page 74 and See 3D connections on page 77 for guidance on how to connect an input source.

Set Input

- **HDMI A, HDMI B, Display Port A, Display Port B**
Tap **OK** to set the input source.
- **Set Multi Input**
Access the sub menu to use this feature. See Set Multi Input below
- **Back**
Tap to return to the Input Menu.

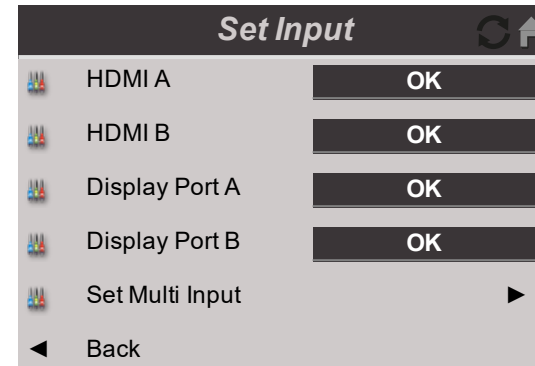

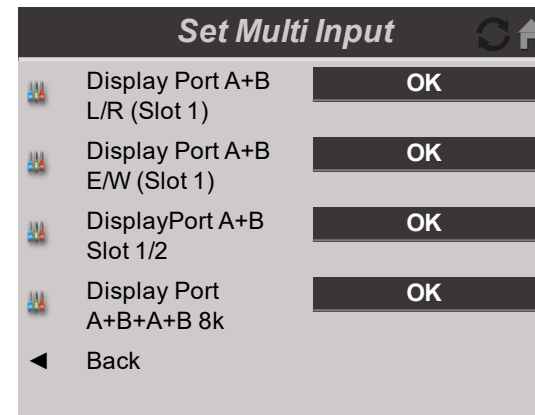

Set Multi Input

- **Display Port A+B L/R (Slot 1), Display Port A+B E/W (Slot 1), DisplayPort A+B Slot 1/2, Display Port A+B+A+B 8k**
Tap **OK** to set the input source.
- **Back**
Tap to return to the Set Input Menu.



Notes

 See Digital inputs and outputs on page 74 and See 3D connections on page 77 for guidance on how to connect an input source.

 See Digital inputs and outputs on page 74 and See 3D connections on page 77 for guidance on how to connect an input source.

Resync

Use this feature to re-acquire an incoming signal on a DisplayPort input. Tap OK to re-acquire the incoming signal on an input port.

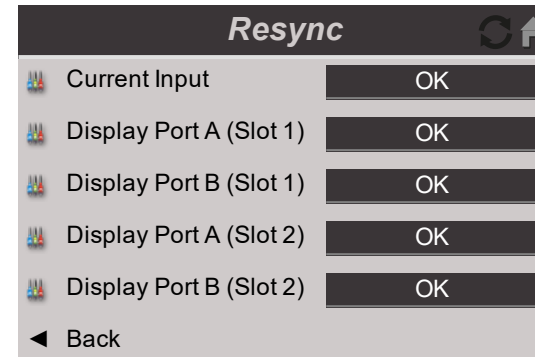

Test Patterns

- **Off, ANSI Chequerboard, Colour Bars, Alignment**
Tap **OK** to display the test pattern.
- **More Test Patterns**
Access the sub menu to use this feature. See More Test Patterns below
- **Back**
Tap to return to the Input Menu.

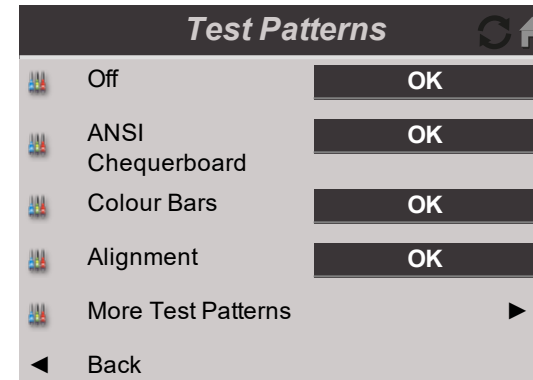

Notes

Selecting a test pattern hides the OSD. Press **EXIT** to hide the test pattern, and then press **MENU** to show the OSD.

Test Patterns are not affected by any color adjustments.

More Test Patterns

- **Off, ANSI Chequerboard, Colour Bars, Alignment**
Tap **OK** to display the test pattern.
- **Back**
Tap to return to the Test Patterns Menu.

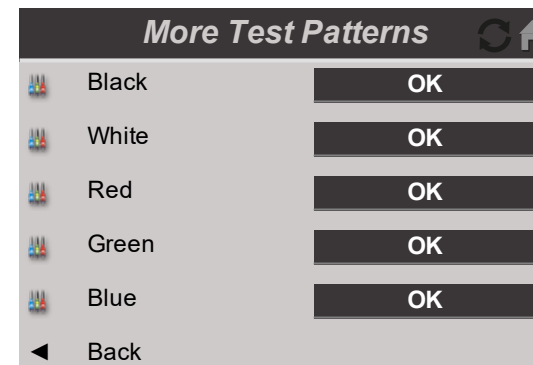

Selecting a test pattern hides the OSD. Press **EXIT** to hide the test pattern, and then press **MENU** to show the OSD.

Test Patterns are not affected by any color adjustments.

Lens

- **Lens Nudge**
Access the sub menu to use this feature. See Lens Nudge below
- **Lens Shift**
Access the sub menu to use this feature. See Lens Shift below
- **Lens Focus**
Access the sub menu to use this feature. See Lens Focus on the facing page
- **Lens Zoom**
Access the sub menu to use this feature. See Lens Zoom on the facing page
- **Lens Advanced**
Access the sub menu to use this feature. See Lens Advanced on page 114
- **Main Menu**
Go back to the main menu.

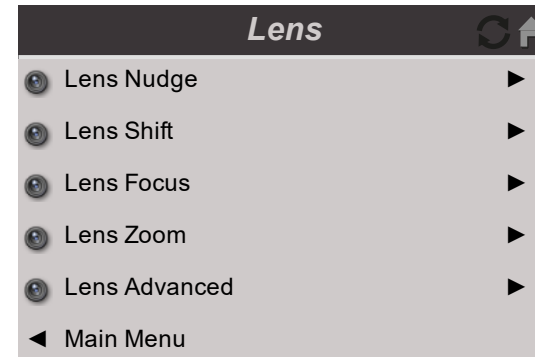

Lens Nudge

- **Left, Right, Up, Down**
Tap **OK** to nudge the position of the display left, right, up or down.
- **Back**
Tap to return to the Lens Menu.

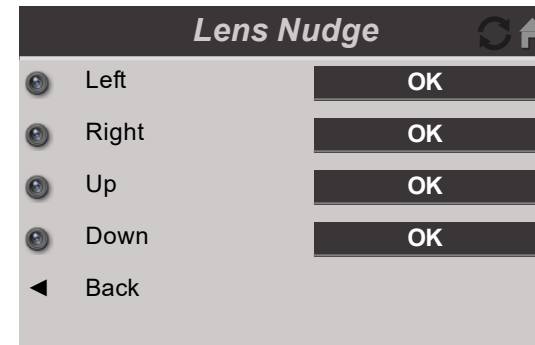

The nudge distance is set in the Lens Advanced menu. See Lens Advanced on page 114.

Lens Shift

- **Left, Right, Up, Down**
Tap **OK** to start shifting the lens display left, right, up or down.
- **Stop**
Press **OK** to Stop the lens shift.
- **Back**
Tap to return to the Lens Menu.

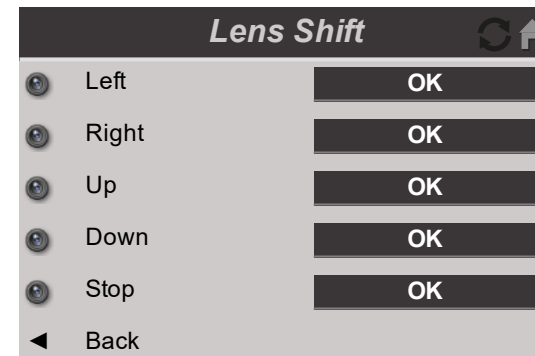

Lens Focus

- **Near, Far**
Tap **OK** to start adjusting the focus towards or away from the lens.
- **Stop**
Press **OK** to Stop the focus adjustment.
- **Nudge Near, Nudge Far**
Tap **OK** to nudge the focus towards or away from the lens.
- **Back**
Tap to return to the Lens Menu.

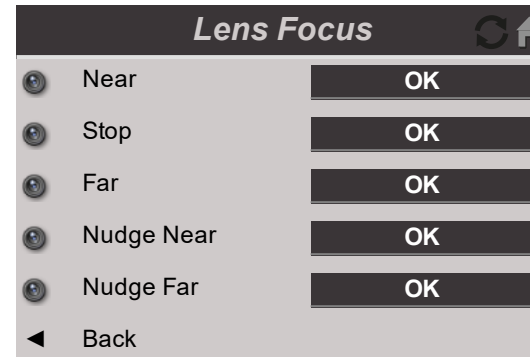



Notes

 The nudge distance is set in the Lens Advanced menu. See Lens Advanced on the next page.

Lens Zoom

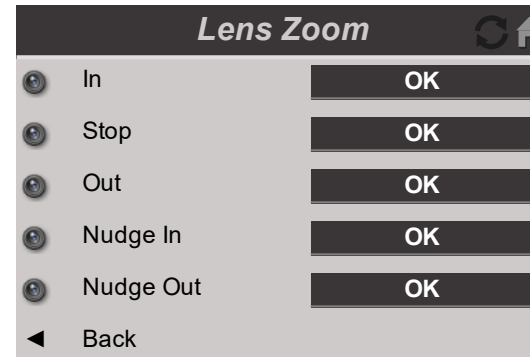
- **In, Out**
Tap **OK** to start zooming into or out of the image.
- **Stop**
Press **OK** to Stop the zoom adjustment.
- **Nudge In, Nudge Out**
Tap **OK** to nudge the focus into or out of the image.
- **Back**
Tap to return to the Lens Menu.



 The nudge distance is set in the Lens Advanced menu. See Lens Advanced on the next page.

Lens Advanced

- Lens Calibrate**
 Access the sub menu to use this feature. See Lens Calibrate below
- Lens Presets**
 Access the sub menu to use this feature. See Lens Presets on the facing page
- Lens Shift Orientation Lock**
 Tick to lock lens calibration.
- Focus Nudge Amount**
 Adjust the nudge amount as required. Sets the focus adjustment when the Nudge Near or Nudge Far option is used in the Lens Focus menu.
- Zoom Nudge Amount**
 Adjust the nudge amount as required. Sets the zoom adjustment when the Nudge In or Nudge Out option is used in the Lens Zoom menu.
- Back**
 Select this to return to the Lens Menu.

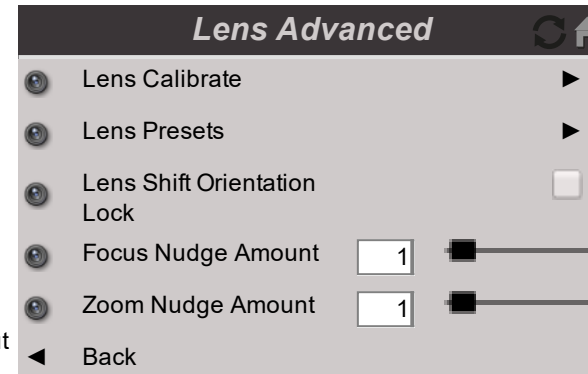

Lens Calibrate

- Focus**
 Tap **OK** to calibrate the focus range of the lens. This establishes minimum and maximum travel distances for the focus control. Allow at least 60 seconds for the calibration to take place.
- Zoom**
 Tap **OK** to calibrate the zoom range of the lens. This establishes minimum and maximum travel distances for the zoom control. Allow at least 60 seconds for the calibration to take place.
- Centre**
 Tap **OK** to calibrate the center point for the lens. This establishes a center point in relation to the zoom and focus controls. Allow at least 60 seconds for the calibration to take place.
- Back**
 Select this to return to the Lens Advanced Menu.

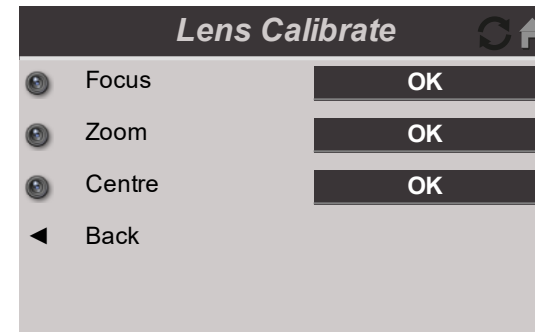

Notes

When a new lens is fitted into the projector, it must be calibrated. It is recommended that you calibrate the focus before calibrating the zoom.

See Satellite Head Control panel on page 65 for guidance on calibrating the lens using the control panel.

See Remote control on page 66 for guidance on calibrating the lens using the remote control.

Lens Presets

- **Recall Preset 1, Recall Preset 2, Recall Preset 3, Recall Preset 4**
Tap **OK** to load the position, zoom, focus and shift adjustment information that has been stored for the preset.
- **Lens Presets Store**
Access the sub menu to use this feature. See Lens Presets Store below
- **Back**
Tap to return to the Lens Advanced Menu.

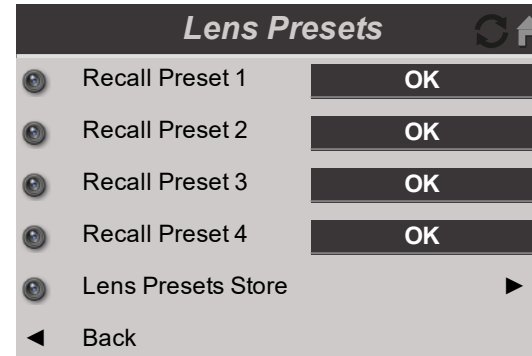

Lens Presets Store

- **Store Preset 1, Store Preset 2, Store Preset 3, Store Preset 4**
Tap **OK** to store the position, zoom, focus and shift adjustment information as a preset.
- **Back**
Tap to return to the Lens Presets Menu.

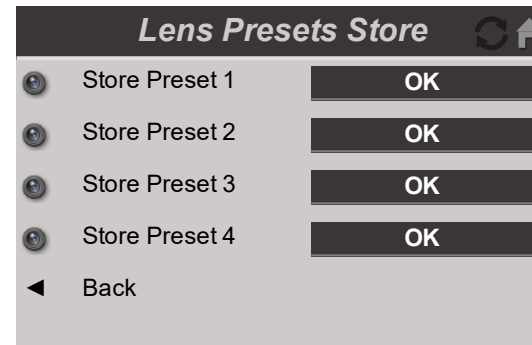

Notes

Image

- **Brightness**
Adjust the brightness level of the projected image as required.
- **Contrast**
Adjust the contrast of the projected image as required.
- **Gamma**
Adjust the gamma of the projected image as required.
Used correctly, the **Gamma** setting can improve contrast while maintaining good details for blacks and whites.
If excess ambient light washes out the image and it is difficult to see details in dark areas, lower the **Gamma** setting to compensate. This improves contrast while maintaining good details for blacks.
Conversely, if the image is washed out and unnatural, with excessive detail in black areas, increase the setting.
- **Geometry**
Access the sub menu to use this feature. See Geometry below
- **Colour**
Access the sub menu to use this feature. See Colour on page 118
- **Main Menu**
Go back to the main menu.

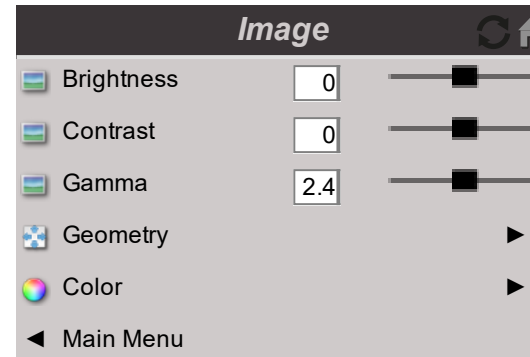

Notes

Geometry

- **Scaler Enabled**
Tick to enable image scaling. Sources with a height of 1080 pixels or less may be doubled in height, and sources with 2048 pixels in width may be doubled in width. Should doubling cause the image to exceed either 2160 pixels in height or 4096 pixels in width the scaling will not occur, and the image will be displayed as delivered and centered.
- **Scaler Points**
Tap to open the Scaler Points editor. See Scaler Points on the facing page
- **Current Orientation**
Information only.
- **Orientation**
Access the sub menu to use this feature. See Orientation on the facing page
- **Back**
Go back to the Image menu.

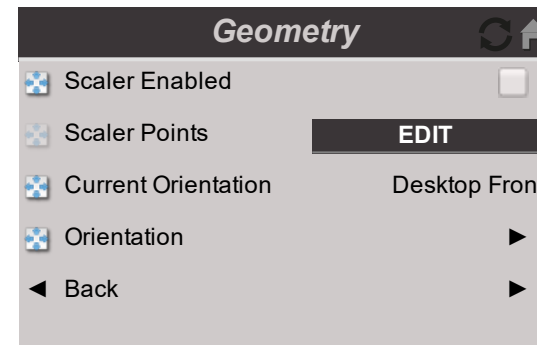

Scaler Points

- **Screen.** Select a Screen and set the aspect ratio for the image, as required.
 - Press and drag a corner to define the size of the projected image relative to the screen.
 - Press and drag the center of the projected image to adjust its location relative to the screen.
 - **Center Screen.** Tap to position the projected image in the center of the screen.
- **Source.** Select to set the aspect ratio to match the source signal.
- **Reset.** Tap to reset any changes.
- **Apply/Exit.** Tap to apply changes to the projected image and return to the Geometry screen.

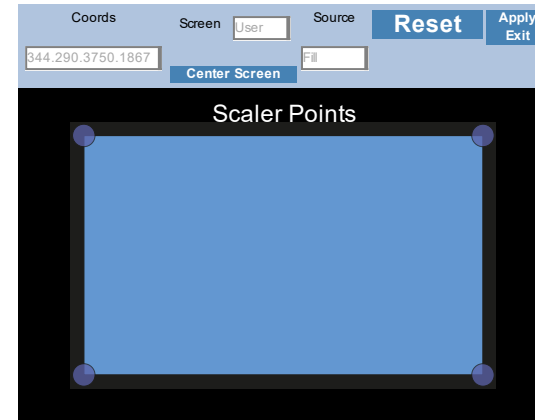

Notes

Orientation

- **Desktop Front, Ceiling Front, Desktop Rear, Ceiling Rear**
Tap **OK** to select the display orientation.
- **Lens Shift Orientation Lock**
Tick to lock lens calibration.
- **Back**
Tap to return to the Lens Menu.

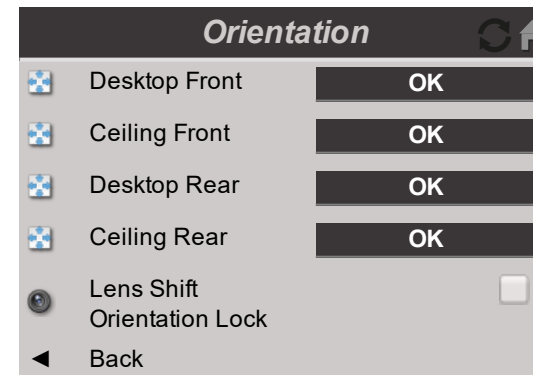

Colour

- **Colour Lift**
Access the sub menu to use this feature. See Colour Lift below
- **Colour Gain**
Access the sub menu to use this feature. See Colour Gain below
- **Advanced Colour**
Access the sub menu to use this feature. See Advanced Colour on the facing page
- **ColourMax**
Access the sub menu to use this feature. See ColourMax on page 120
- **Back**
Go back to the Image menu.

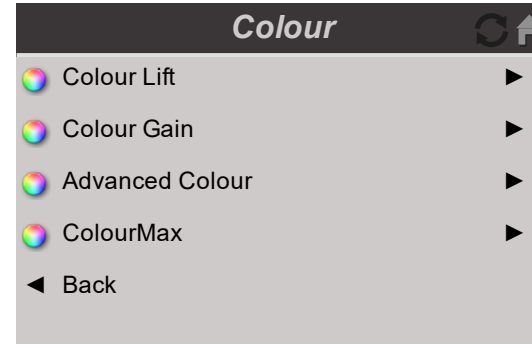

Colour Lift

- **Red Lift, Green Lift, Blue Lift**
Adjust the black levels of each color on the projected image as required.
- **Back**
Go back to the Colour menu.

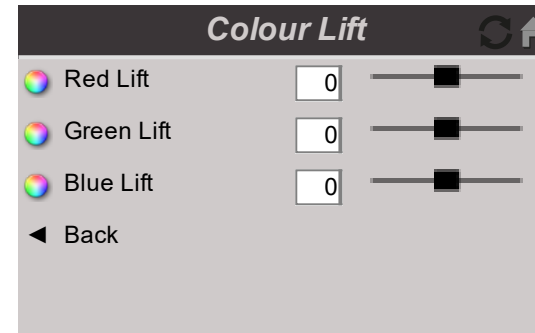

Colour Gain

- **Red Gain, Green Gain, Blue Gain**
Adjust the bright part of each color on the projected image as required.
- **Back**
Go back to the Colour menu.

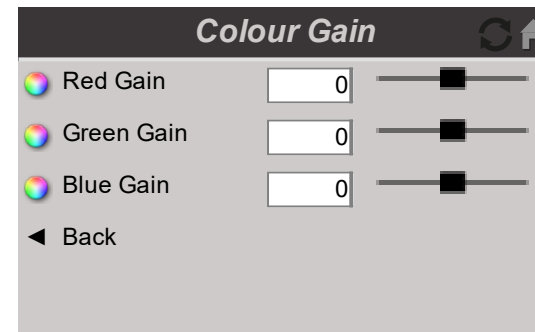

Notes

Advanced Colour

- **Current Colour Space**
Information only
- **Colour Space**
Access the sub menu to use this feature. See Colour Space below
- **Current Colour Sampling**
Information only
- **Colour Sampling**
Access the sub menu to use this feature. See Color Sampling below
- **Colour Preset**
Access the sub menu to use this feature. See Colour Preset on the next page
- **Back**
Go back to the Image menu.

Colour Space

- **Auto**, RGB, YUV SD, YUV HD
Tap **OK** to set the color space, as required.
- **Back**
Go back to the Advanced Colour menu.

Color Sampling

- **Auto**, 4:4:4, 4:4:2, 4:2:0
Tap **OK** to set the color sampling value, as required. This adjusts the compression of the colors used in the projected image.
- **Back**
Go back to the Advanced Colour menu.

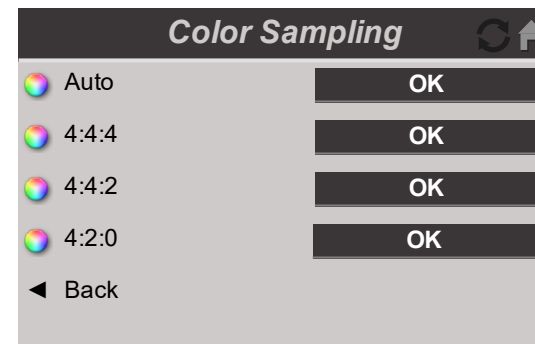
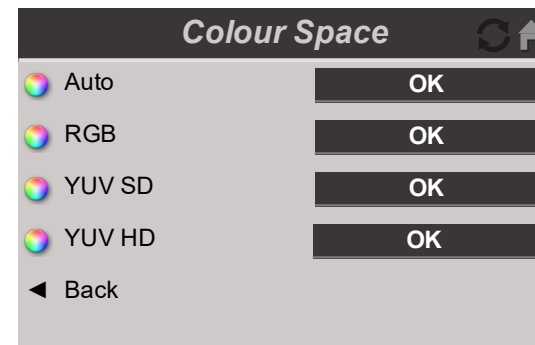
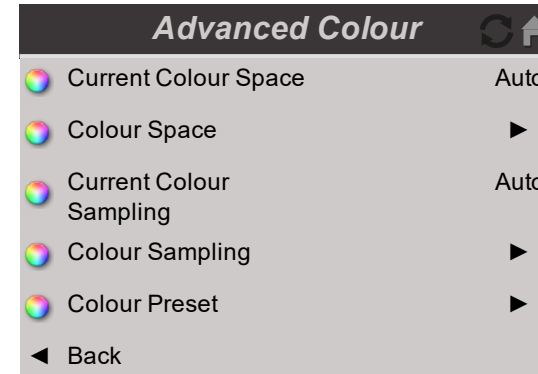

Notes

Colour Preset

- **User**, Peak, REC709, REC601, 3200 K, 5400 K, 6500 K, 8000 K, 9000 K, Extended, Ultra Tap **OK** to set the color sampling value, as required. This adjusts the compression of the colors used in the projected image.
- **Colour Preset**
Tap to show more color preset options.
- **Back**
Go back to the Advanced Colour menu.

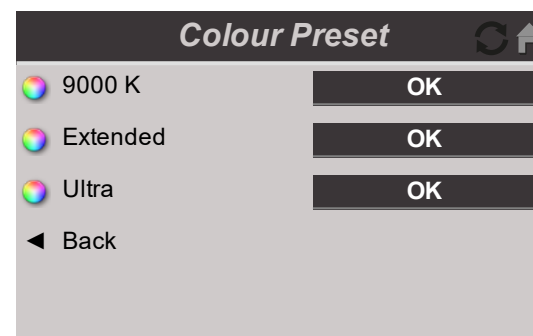
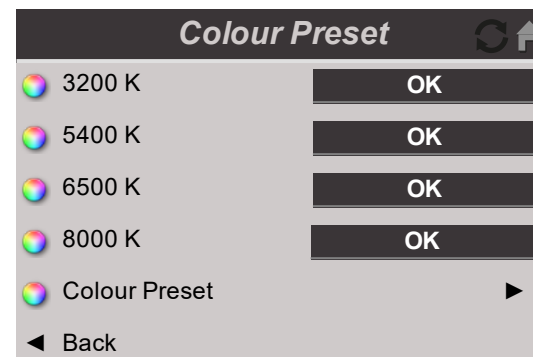
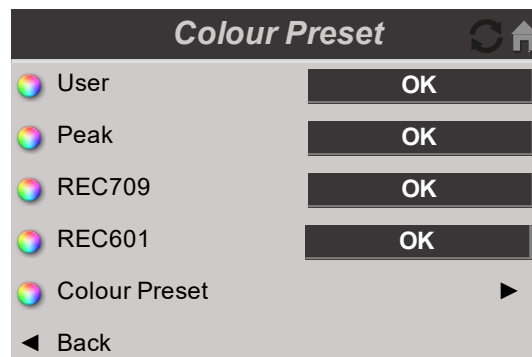

Notes

ColourMax

ColorMax permits seven point color matching of red, green, blue, yellow, cyan, magenta and white.

You can enter your own gamut values here, or edit values you have imported using the **Projector Controller** software. You can also set a default color gamut, choose from Peak or REC709.

Defining your own colorspace with individual x and y coordinates for each color enables you to match not only the whites but each individual color as well.

- **Target Colour**
Access the sub menu to use this feature. See Target Colour on the facing page
- **Measured Colour**
Access the sub menu to use this feature. See Measured Colour on the facing page
- **Gamut Chart**
Access the sub menu to use this feature. See Gamut Chart on page 122
- **Back**
Go back to the Colour menu.

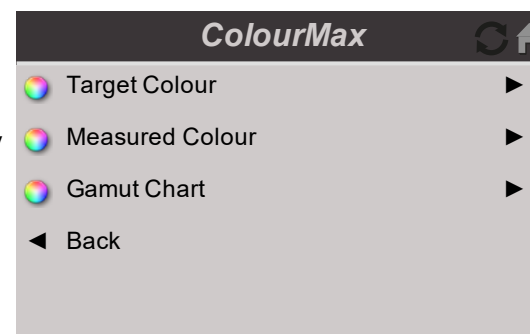

*The **Projector Controller** software is available for download from the Digital Projection website, free of charge.*



This tool is best used in conjunction with a specialized light meter (a photo spectrometer) to measure color parameters within a particular installation. However, the preloaded generic factory default data set is designed to give more than satisfactory results.

Target Colour

- **Red, Green, Blue, White**
Adjust the x and y coordinates of each color on the projected image as required.
- **Back**
Go back to the Colour menu.

Target Colour

Red	0.708	0.292
Green	0.17	0.797
Blue	0.131	0.046
White	0.313	0.329
◀ Back		

Measured Colour

- **Red, Green, Blue, White**
Adjust the x and y coordinates of each color on the projected image as required.
- **Factory Setting**
Tap **OK** to restore the factory color settings.
- **Back**
Go back to the Colour menu.

Measured Colour

Red	0.708	0.292
Green	0.17	0.797
Blue	0.131	0.046
White	0.313	0.329
Factory Setting	OK	
◀ Back		

Notes

Gamut Chart

Edit the gamut values for each individual color, as required.

- Press and drag a color to define its x and y coordinates.
- Tap a white point value to set it. Choose from **3200K, 4800K, 5500K, 6500K, 9000K**.
- **Zoom Red, Zoom Green, Zoom Blue**
Tap to zoom into the color on the chart.
- **Zoom Reset**
Tap to reset the zoom.
- **TCGD Peak**
Tap to set the maximum values for each color.
- **Apply**
Tap to apply any changes.
- **Exit**
Go back to the ColourMax menu.

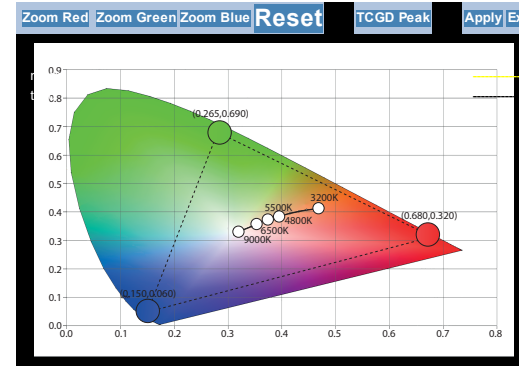

3D

Use this menu to enable, disable and set up 3D input, as follows:

- **3D Enabled**
Tick to enable 3D.
- **3D Dark Time**
Access the sub menu to use this feature. See 3D Dark Time on the facing page
- **3D Format**
Access the sub menu to use this feature. See 3D Format on the facing page
- **3D Sync**
Access the sub menu to use this feature. See 3D Sync on page 124
- **3D Advanced**
Access the sub menu to use this feature. See 3D Advanced on page 126
- **Main Menu**
Go back to the main menu.

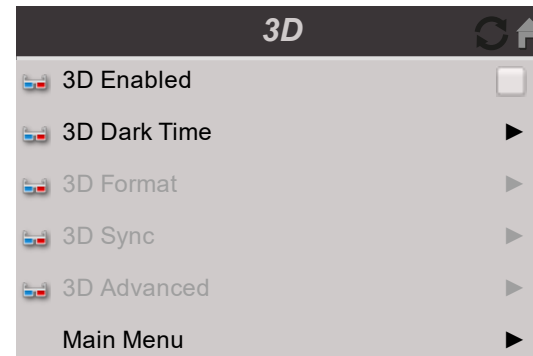

Notes

- ☞ *A frame rate multiplier is available via the projector controller application*
- ☞ *Dark Time is only applied if it is applicable to the source frame rate.*
- ☞ *See 3D types on page 99 for more information about 3D settings.*

3D Dark Time

Use this menu to enable, disable and set up 3D input, as follows:

- **Current Dark Time**
Information only
- **Set Dark Time**
Access the sub menu to use this feature. See Set Dark Time below
- **Back**
Go back to the 3D menu.

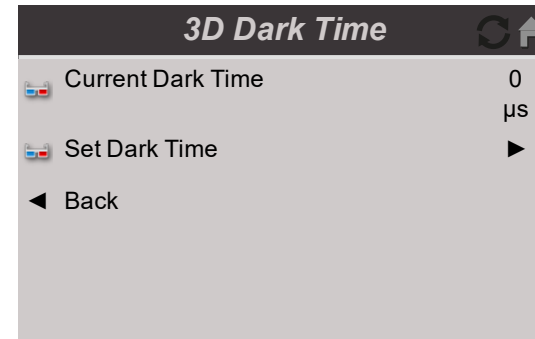

Notes



Dark Time is only applied if it is applicable to the source frame rate.

Set Dark Time

- **Off, 250, 500, 1000, 1500, 7000**
Tap **OK** to set the dark time rate, as required.
- **Set Dark Time**
Tap to show more dark time options.
- **Back**
Go back to the 3D Dark Time menu.

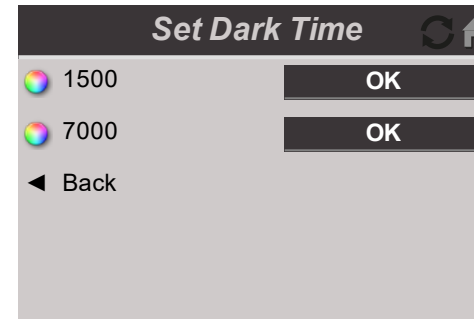

3D Format

- **Current Format**
Information only
- **Set 3D Format**
Access the sub menu to use this feature. See Set 3D Format on the next page
- **Back**
Go back to the main menu.

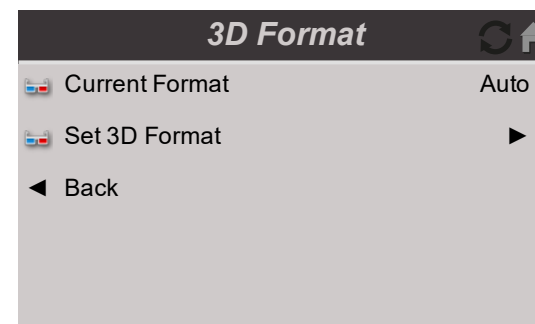

Set 3D Format

- **Auto**, Sequential, Frame Packing, Top and Bottom, Side by Side
Tap **OK** to set the 3D format, as required.
Sequential is for sources where Left and Right eye images are delivered as alternate frames from a single input.
- **Back**
Go back to the 3D Format menu.

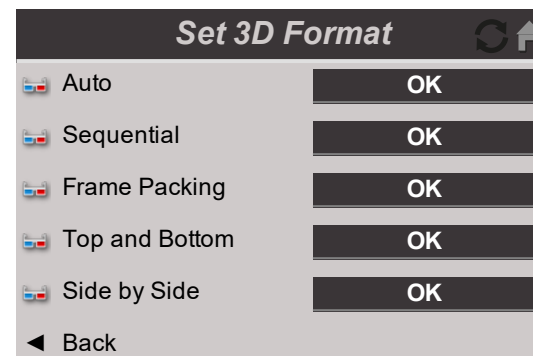

3D Sync

- **3D Sync In**
Access the sub menu to use this feature. See 3D Sync In below
- **3D Sync Out**
Access the sub menu to use this feature. See 3D Sync Out on the facing page
- **Back**
Go back to the 3D menu.

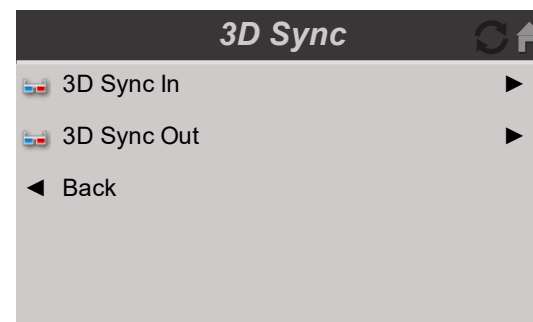

3D Sync In

- **Enable**
Tick to enable 3D sync in.
- **Current Polarity**
Information only
- **Sync In Polarity**
Access the sub menu to use this feature. See Sync In Polarity on the facing page
- **Back**
Go back to the 3D menu.

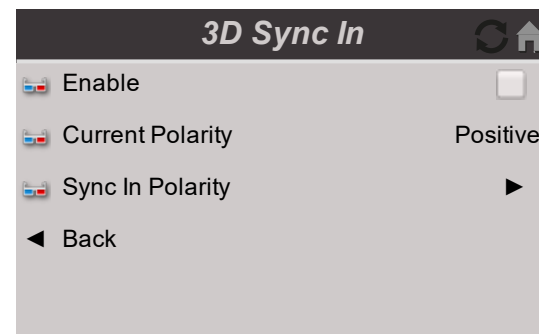

Notes

Sync In Polarity

- **Positive, Negative**
Tap **OK** to set the Sync In polarity.
- **Back**
Tap to return to the 3D Sync In menu.

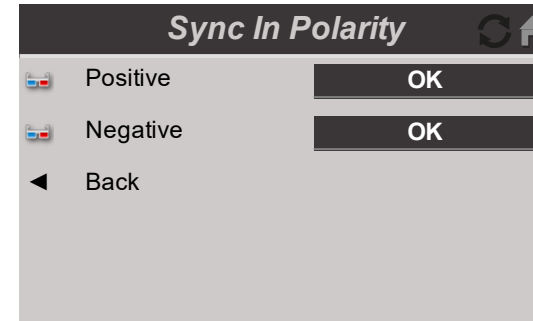
**3D Sync Out**

- **Enable**
Tick to enable 3D sync out.
- **Current Polarity**
Information only
- **Sync Out Polarity**
Access the sub menu to use this feature. See Sync In Polarity above
- **Offset (μ s)**
Adjust to compensate for image overlapping (ghosting) when viewed through 3D glasses.
- **Back**
Go back to the 3D menu.

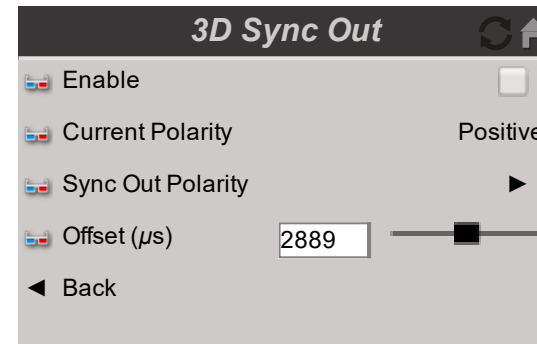
**Sync Out Polarity**

- **Positive, Negative**
Tap **OK** to set the Sync Out polarity.
- **Back**
Tap to return to the 3D Sync Out menu.

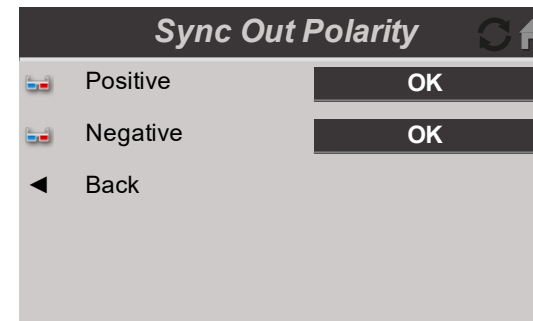
**Notes**

3D Advanced

- **Current Dominance**
Information only
- **Set Dominance**
Access the sub menu to use this feature. See Set Dominance below
- **Current Multiplier**
Information only
- **Set Multiplier**
Access the sub menu to use this feature. See Set Multiplier below
- **Back**
Go back to the 3D menu.

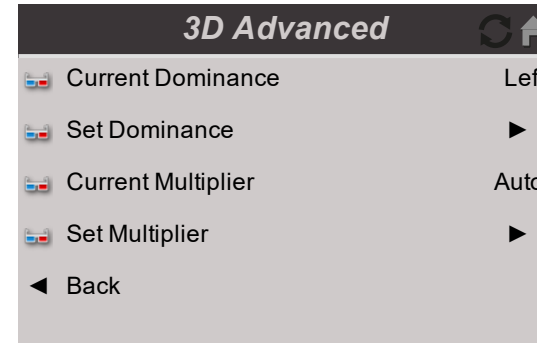

Set Dominance

- **Left, Right**
Tap **OK** to display the left-eye and right-eye images in the appropriate order.
- **Back**
Tap to return to the 3D Advanced menu.

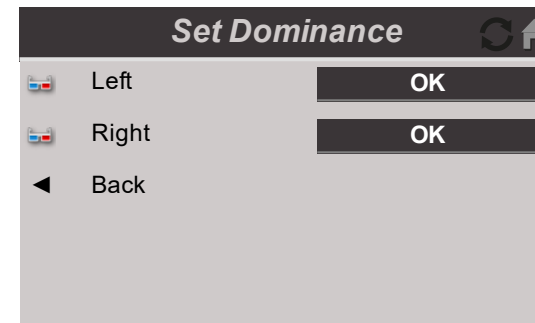

Set Multiplier

- **Auto, x1, x2, x3**
Tap **OK** to set the appropriate framerate multiplier.
- **Back**
Tap to return to the 3D Advanced menu.

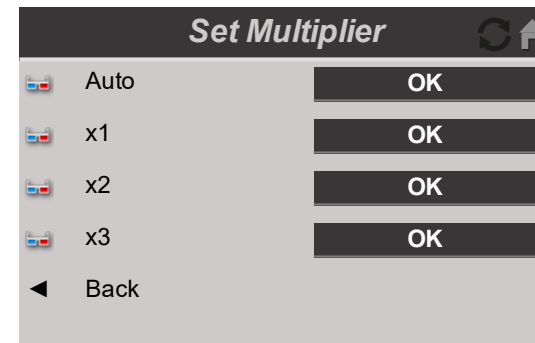

Notes

 A frame rate multiplier is available via the projector controller application

System

- **Laser**
Access the sub menu to use this feature. See Laser below
- **Standby**
Access the sub menu to use this feature. See Standby below
- **Remote Control**
Access the sub menu to use this feature. See Remote Control on the next page
- **OSD**
Access the sub menu to use this feature. See OSD on the next page
- **Advanced**
Access the sub menu to use this feature. See Advanced on the next page
- **Main Menu**
Go back to the main menu.

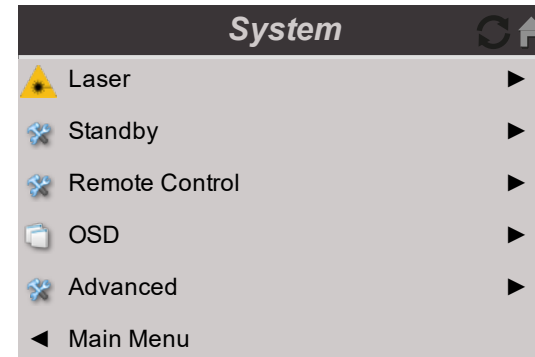

Laser

- **Laser On, Laser Off**
Tap **OK** to switch the laser on or off.
- **Number of MLS**
Set the number of MLS installed.
- **Back**
Go back to the System menu.

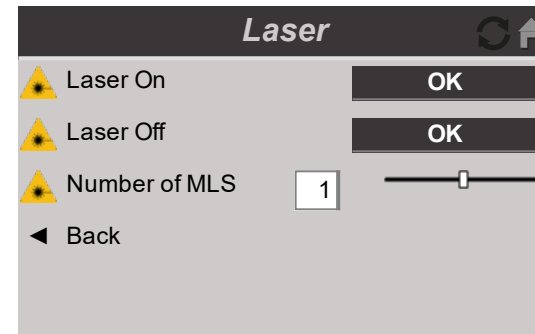

Standby

- **Allow Standby**
Tick to enable standby mode.
When enabled, the system will activate the standby mode if no signal is detected for the duration of the standby timeout timer.
- **Standby Timeout (mins)**
Adjust to set the standby timeout timer.
- **Back**
Go back to the System menu.

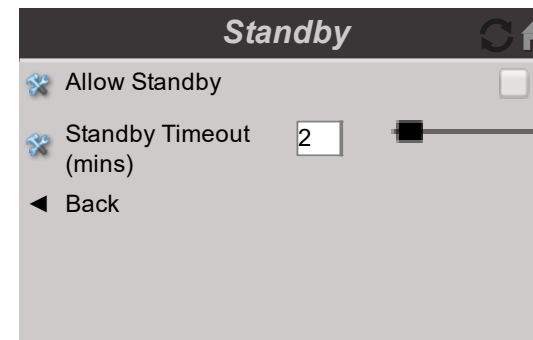

Notes

Remote Control

- **Front Sensor, Rear Sensor, Wired**
Tick to enable the remote control sensors or wired input on the projector head.
- **Back**
Go back to the System menu.

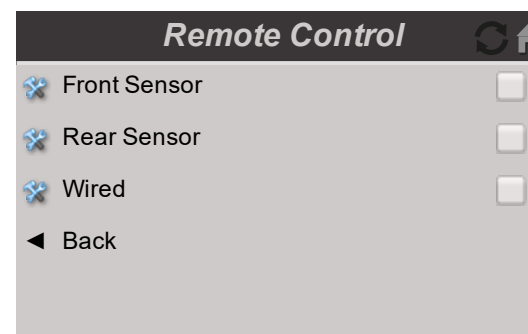

OSD

- **Enabled**
Tick to enable OSD.
When enabled, the OSD can be displayed over the projected image.
- **Timeout (secs)**
Choose how long the OSD should remain on screen if no buttons are pressed.
- **Confirmation Prompts**
Enable this to require a confirmation when a command is used in the OSD.
- **Source Change**
Enable this to display a message when the source input is changed.
- **Zoom**
Enable this to double the size of the OSD.
- **Back**
Go back to the System menu.

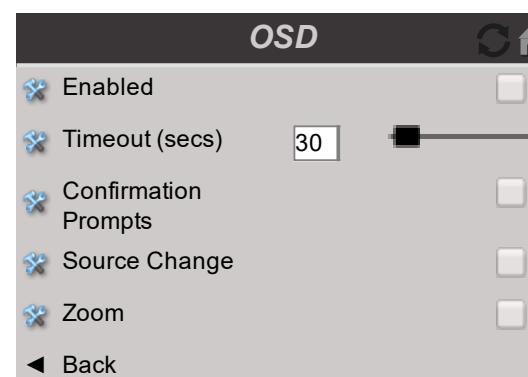

Advanced

- **Picture Mute**
Tap **OK** to hide the projected image.
- **Picture Unmute**
Tap **OK** to show the projected image.
- **High Altitude**
Tick to activate High Altitude mode.
- **Factory Reset**
Tap **OK** to restore the default factory settings.
- **Main Menu**
Go back to the main menu.

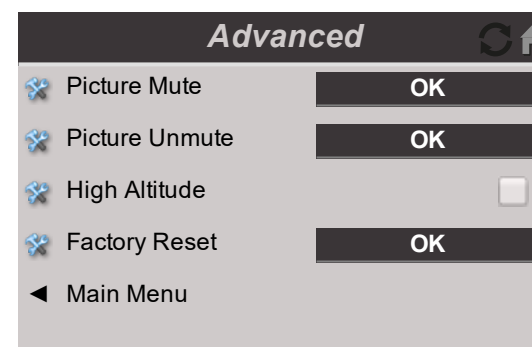

Notes

Information

Each submenu in this menu provides information about this system.

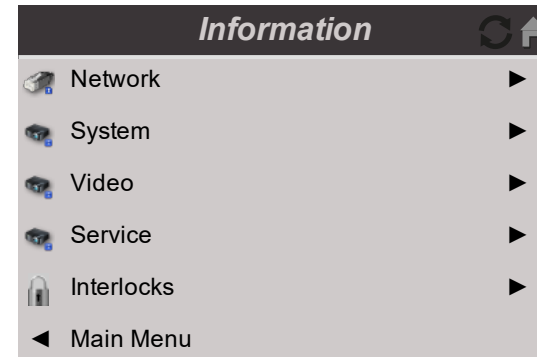

Network

Information Only

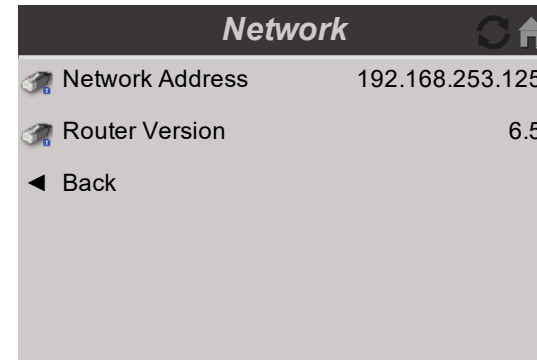

System

Information Only

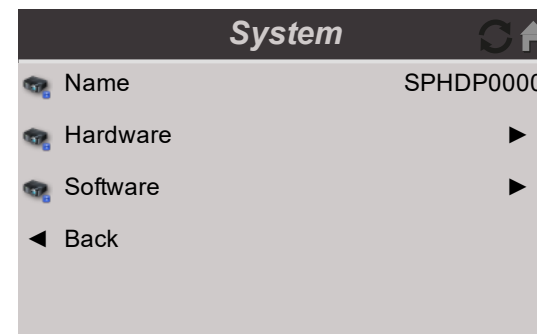

Notes

Hardware

Information Only

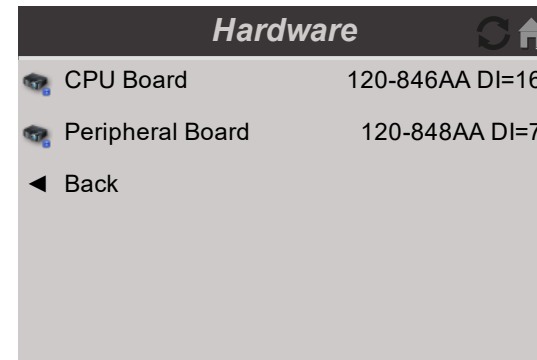

Software

Information Only

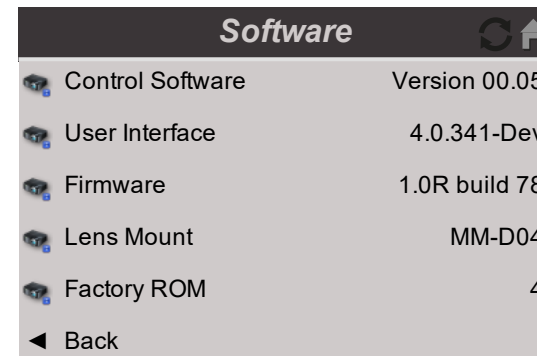

Video

Information Only

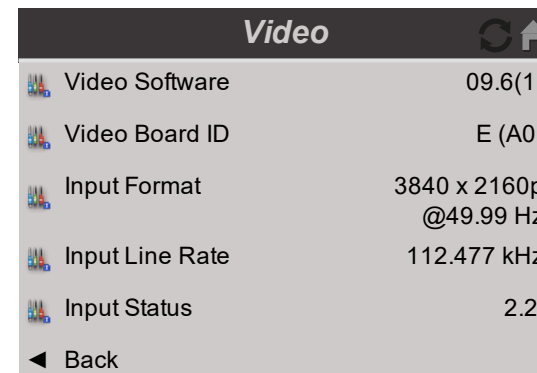

Notes

Service

Information Only

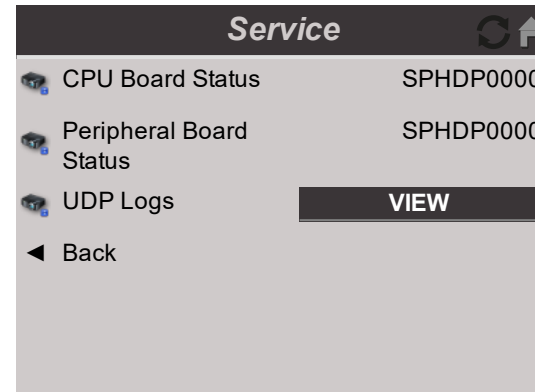

Notes

Interlocks

Information only.

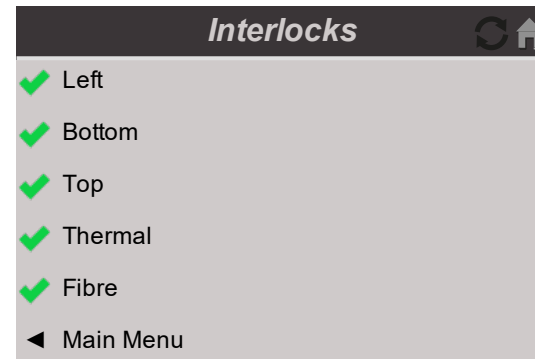
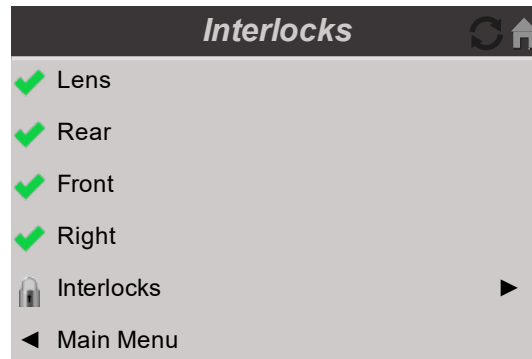

This page is intentionally left blank



Satellite Insight 8K 60

Digital Video Projector

MLS 10000 TOUCHSCREEN OPERATING GUIDE



A brand of  DELTA

Introduction to the MLS 10000 Touchscreen

This section describes the operation of the Satellite Modular Laser Source (MLS 10000). Please refer to the page 13 for guidance on installing the MLS 10000 as part of the Satellite system. Your MLS 10000 has the following key features:

- RGB Laser light source
- Generates 10,000 Lumens per MLS
- Can be paralleled up with other modules for increased light output with the appropriate SLC
- Can be linked to up to 4 paralleled Satellite Heads for multiple displays with the appropriate SLC

The MLS displays a touch screen menu when the power is on.

Using the menus

The MLS displays a touch screen menu when the power is on.

Some menus have items that are hidden by the bottom of the screen. Press and drag to scroll the menu up and down.

When you open a menu, the page consists of the following elements:

- Title bar at the top shows which menu you have accessed. Additional buttons are available in the title bar:
 - tap the refresh button to refresh the information on the screen
 - tap the home button to return to the main menu
- Available and unavailable items Unavailable items appear a pale gray color. Whether an item is available may depend on other settings.
- The text or symbol to the right of an item shows whether the item:
 - has information only
 - has a value that can be selected. The current selection is displayed in a box. Tap to select a new option
 - has a tick box. A tick indicates that the feature is enabled. Tap to enable or disable the feature
 - has a slider. A box displays the current value of the setting. Press and drag the slider to adjust the value
 - opens a sub-menu. Tap the arrow button to open the sub menu
 - executes a command. Tap the command button to execute.

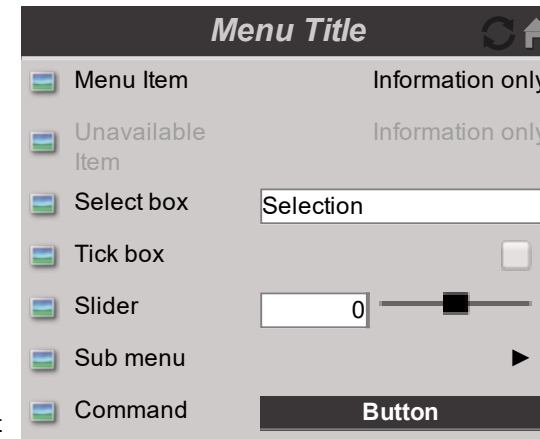

Inside a Menu

Notes

Main Menu

- **Laser, Setup, Information, Help.**
Tap to open these menus and access various settings.

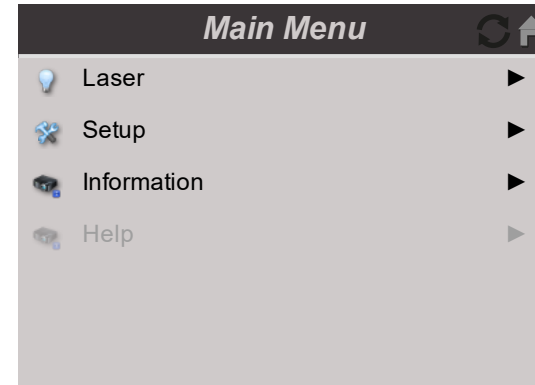

Touchscreen Display: Top Level Menu

Laser

- **Power Mode**
 - **Eco** will automatically set the laser power to 80%.
 - **Normal** will set the power to 100%.
 - Set to **Custom** if you wish to adjust the power manually.
- **Power Level**
This setting is only available if **Power Mode** is set to **Custom**.
Choose a value between 20 and 100, ranging from 20% to 100% laser power.
- **Constant Brightness**

The Constant Brightness setting will maintain the projectors set brightness until the maximum laser power has been reached (this maximum laser power will decrease overtime). Hence, the lower the set Constant Brightness power level the longer the set brightness output will be maintained.

- **Main Menu**
Tap to go back to the main menu.

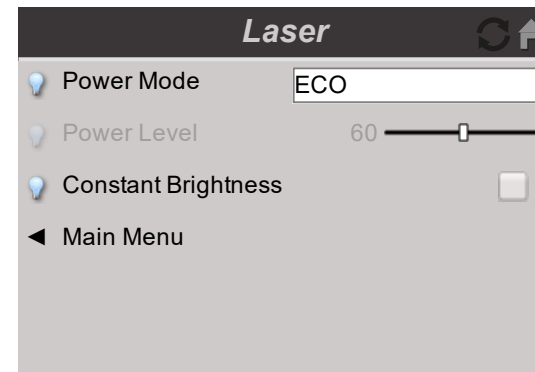

Notes

Setup

- **OSD Settings**
Press **ENTER/OK** to open the submenu.
- **Main Menu**
Go back to the main menu.

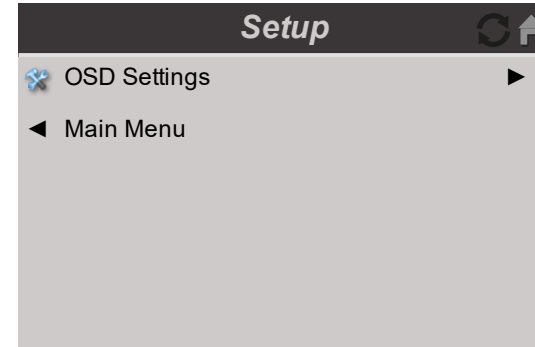

OSD Settings

- **Language** sets the OSD language.
- **Back**
Tap to go back to the setup menu.

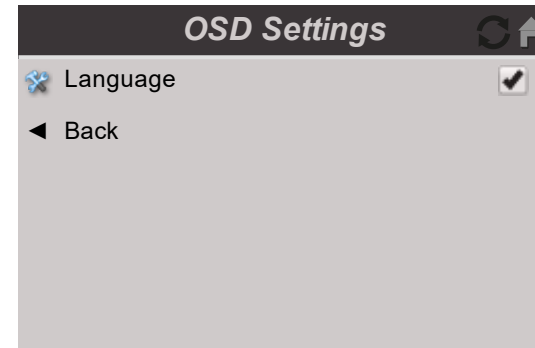

Network

- **IP, Subnet Mask, Gateway, MAC**
These settings are read-only. See Network on page 146 for guidance on network settings in the SCM.
- **Main Menu**
Tap to go back to the main menu.

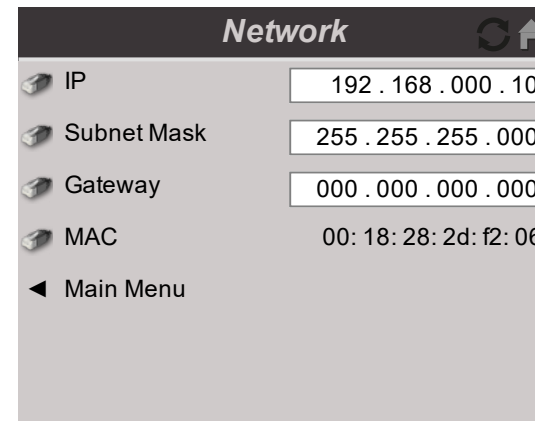

Notes

Information

This menu gives information about software and hardware configuration, input source and laser operating times. It also allows you to restore the factory default settings.

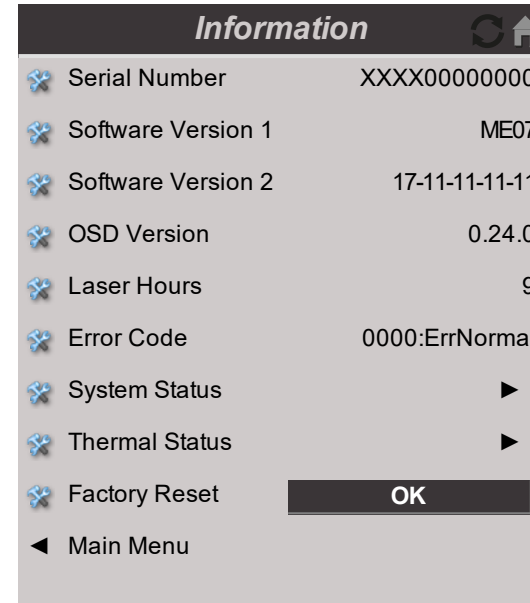

System Status

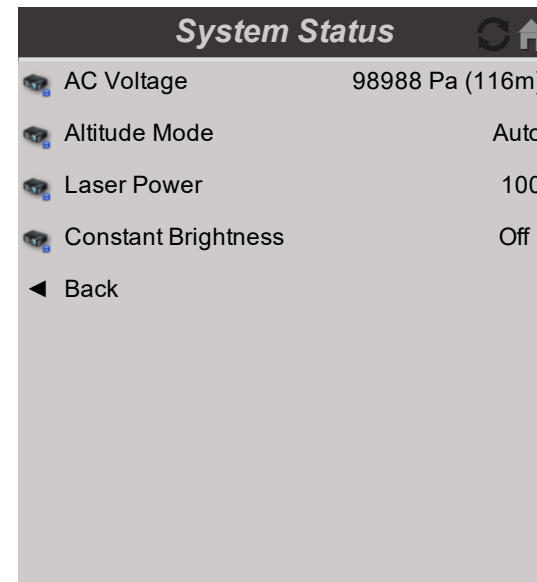

Notes

Thermal Status

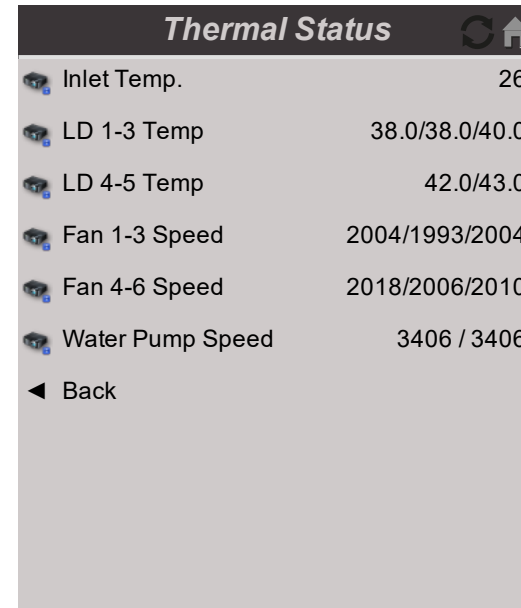

Factory Reset

To restore the factory default settings:

1. Navigate to **Factory Reset** and press **ENTER/OK**.
2. When prompted, press **OK** to confirm your choice, or press **Cancel** to cancel.

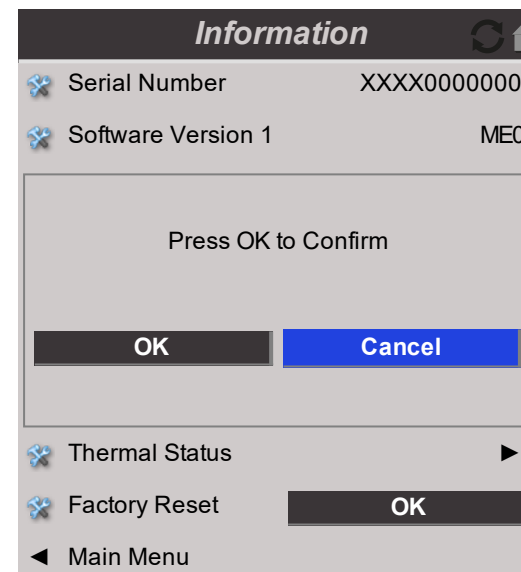

Notes

 *Factory reset does not reset the Network settings, or High Altitude mode*



Satellite Insight 8K 60

Digital Video Projector

MLS 20000 / MLS 30000 LCM SCREEN OPERATING GUIDE



A brand of 

Introduction to the MLS 20000 / MLS 30000 LCM Screen

This section describes the operation of the Satellite Modular Laser Source (MLS 20000 / MLS 30000). Please refer to the page 13 for guidance on installing the MLS as part of the Satellite system. Your MLS has the following key features:

- RGB Laser light source
- Generates 20,000 Lumens per MLS 20000
- Generates 30,000 Lumens per MLS 30000
- Can be paralleled up with other modules for increased light output with the appropriate SLC
- Can be linked to up to 4 paralleled Satellite Heads for multiple displays with the appropriate SLC

The MLS displays a LCM screen menu when the power is on.

LCM Pages

The information on the LCM is displayed in multiple pages.

- Press and hold the **Info Key** for more than 1 second to show the next page. **1**
The pages are displayed in the following order:
 1. System Status (default)
 2. System Information
 3. Network Information
 4. Thermal Information
 5. Error Page

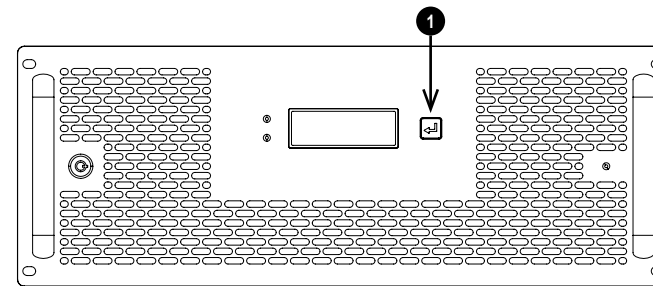

System Status

Information only:

- Model Name
- Status

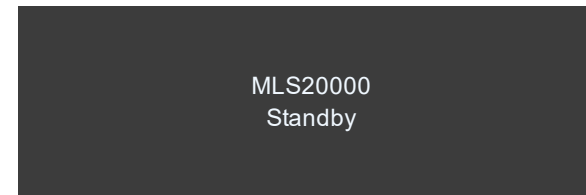

Notes

The LCM is view only information. The features of the MLS are controlled via served web pages. The served web pages can be accessed via the SCM touchscreen or a connected device. See Introduction to the SCM Touchscreen on page 144 for guidance on the SCM touchscreen. See Served web pages on page 179 for guidance on using the served web pages.

The controls in the served web pages for the MLS 20000 / MLS 30000 are the same as the controls for the MLS 10000. See Introduction to the MLS 10000 Touchscreen on page 134.

System Information

Information only:

- Model Name
- Serial Number
- FW Version
- Laser Status (Power)

```
Model: MLS20000
SN: xxxxxxxxxxxx
MCU-IF-LD-PI
Light Off
```

Network Information

Information only:

- IP Address
- SubnetMask
- GateWay
- MAC

```
IP:192.168.253.125
Mask:255.255.255.0
GWay:192:168:253:241
MAC:D8:27:eb:2a:e2:e3
```

Thermal Information

Information only:

- Temperature: LD B
- Temperature: LD G / LD R
- Laser Hours
- AC Voltage

```
Inlet Temp LD B: 0°C
G: 0°C R: 0°C
Laser Hours: xxxxx
Voltage: N/A
```

Error Page

Information only:

- Model Name
- Error Code
- Description

```
MLS20000
ERROR CODE:0x0000
NORMAL
```

Notes

This page is intentionally left blank

SCM TOUCHSCREEN OPERATING GUIDE



Introduction to the SCM Touchscreen

This section describes the operation of the Satellite Control Module (SCM) touchscreen control panel. Please refer to the page 13 for guidance on installing the SCM as part of the Satellite system. Your SCM has the following key features:

- Centralized system configuration management and control
- User remote control via LAN.
- System operation monitoring, including Interlocks and warnings.

The SCM displays a touchscreen menu when the power is on.

Notes

Using the menus

The SCM displays a touch screen menu when the power is on.

System Configuration

- **System Controller.**
Tap to open this menu and access various settings.
- **Component.**
A component sub menu provides information about another module installed in the system. This could be a Satellite Head or an MLS. The components shown will match the components installed in your system. This could be 1-4 MLS and 1 Satellite Head or 1 MLS and 1-4 Satellite Heads. There are two levels of access:
 - **Information Only**
Tap a component to open a submenu that shows view only information about the module.
 - **Served Web Page**
This allows you to adjust the settings of the module.
Tap and hold the menu icon in the header to enable a link to the served web page for the modules. The component names will turn green. Tap a component menu to access its touchscreen menus. A message is displayed to indicate that the SCM is connecting to the module. The served web pages for the module are displayed when the connection is established.

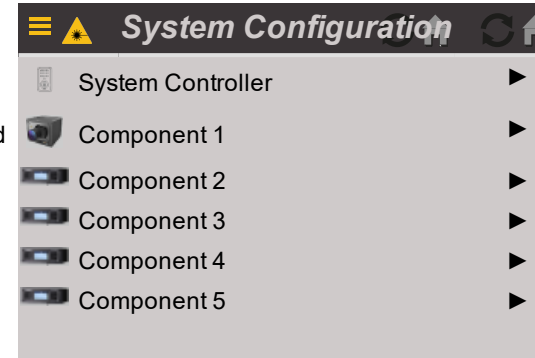

On Screen Display (OSD): Top Level Menu

Main Menu

- **Laser Power, Interlocks, Network, Information.**
Tap to open these menus and access various settings.
- **Help.**
Use a QR code scanner to open a webpage containing the manual documentation for this system.

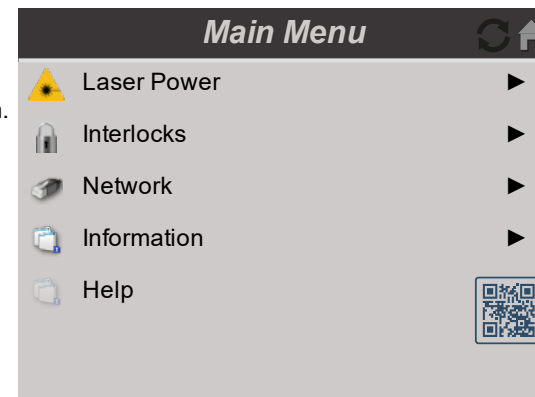

On Screen Display (OSD): Top Level Menu

Notes

Laser Power

- **Laser ON.**
Tap to turn the laser on. A message is displayed to indicate that the system interlocks are engaging. The laser will switch on when the interlocks are engaged.
- **Laser OFF.**
Tap to turn the laser off.

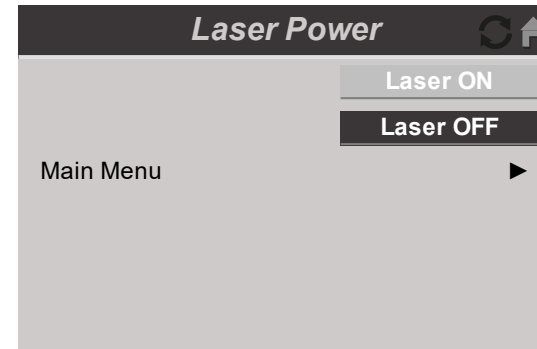

Interlocks

Displays the current state of interlocks in the Satellite system:

- A green tick indicates that the interlock is currently closed and the system can operate as normal.
- A red error symbol indicates that the interlock has been opened.

Every interlock must be closed to allow the system to operate as normal.

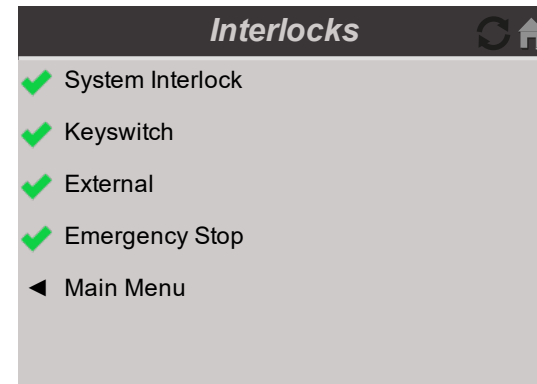

See *Interlock Switches* on page 25 for more information about system interlocks.

Network

- **DHCP, Network Address, Subnet Mask**
Tick **DHCP** to assign the IP address via a DHCP server.
If **DHCP** is not enabled, edit the Network address and Subnet Mask as required.
- **Main Menu**
Go back to the main menu.

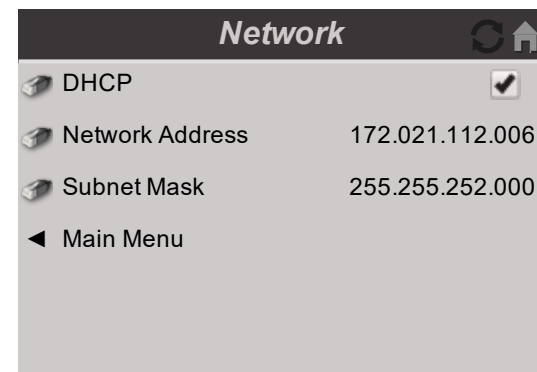

Information

Each submenu in this menu provides information about this system.

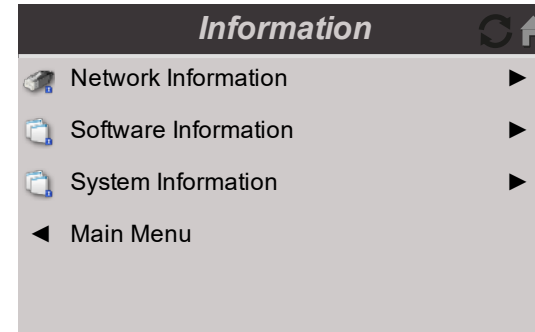

Network Information

Information Only

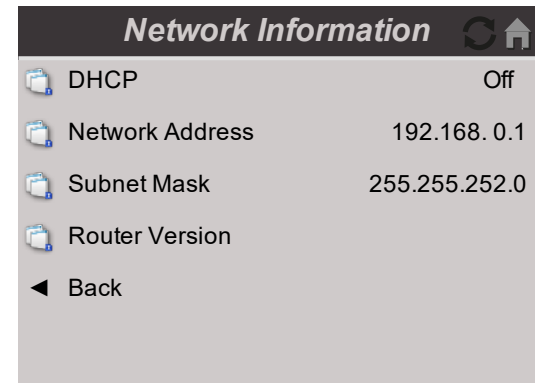

Software Information

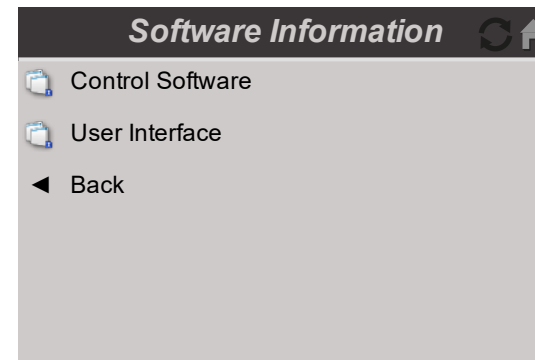

Information Only







Notes

System Information



Information Only





System Information  

 Model	Satellite Control Module
 Name	SCM0004
 Serial Number	0004
 Hardware Information	▶
 Service Information	▶
◀ Back	

Hardware Information

Information Only

Hardware Information  

 Board Type	9
 Edition	A
 Artwork	A
 Mod State	5
◀ Back	

Notes

Service Information

Information Only



Component menu

Information Only

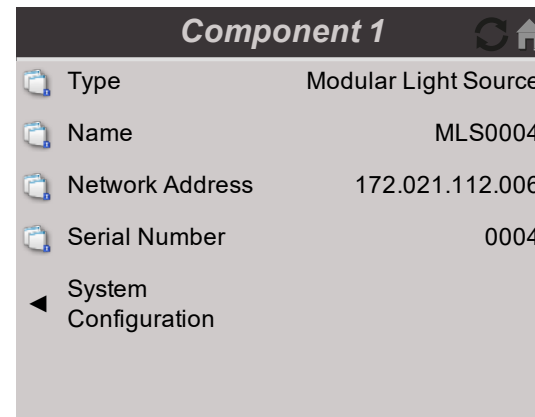

Example Component

Notes

This page is intentionally left blank

Satellite Insight 8K 60

Digital Video Projector
REFERENCE GUIDE



A brand of  **DELTA**

Appendix A: Product labels

Satellite Head

Notes

DIGITAL PROJECTION

UKCA CE RoHS WEEE

Name of Product: DLP Projector
Nom du produit: DLP Projecteur
产品名称/產品名稱: 数字投影机 / 數位投影机
Model / Modèle: Satellite Insight Head 8K
型号/型號: Satellite Insight Head 8K
Part No. / Numéro de pièce: 120-887C
零件号/零件號: 120-887C
Serial No. / Numéro de série: *WYWXXCYS555*
序号/序號: *WYWXXCYS555*

Power / Puissance: 200-240V ~ 50/60Hz 1.2A
电源/電源: 110-130V ~ 50/60Hz 2.4A

警告: 此为A 级产品。在生活环境中, 该产品可能会造成无线电干扰。在这种情况下, 可能需要用户对干扰采取切实可行的措施。
警告使用者: 这是非屏蔽的无线电产品。在居住的环境中使用时, 可能会造成射频频干扰, 在这种情况下, 使用后会要求采取某些适当的对策。

WARNING
ATTENTION
Isolate mains before removing cover.
Isoler les conduites avant d'enlever le couvercle.
注意/注意 打开前先切断主电源/打開前先切斷主電源

To reduce the risk of fire or electric shock, do not expose this equipment to rain or moisture.
Pour réduire le risque d'incendie ou d'électrocution, n'exposez pas cet équipement à la pluie ou à l'humidité.
请勿将投影机置于雨中或潮湿环境中以降低火灾或电击风险。
請勿將投影机放置在雨中或潮湿环境中以降低火灾或电击的风险。

This device complies with Part 15 of the FCC Rules. Operation is subject to the following two conditions: (1) This device may not cause harmful interference. (2) This device must accept any interference received, including interference that may cause undesired operation.
CANICES-003(A)/NMB-003(A)

Delta Electronics (Jiangsu) Ltd.
No.1688, Jiangning East Rd.,
Wujiang Economic and Technological Development Zone,
Suzhou City, Jiangsu Province, P.R.C.215200

M/F Date : YYYY.MM.DD
製造地: 中国 / 製造地: 中國 / Made in China

Digital Projection Limited
英国居住有限公司 / 英國居住有限公司
Greenside Way, Middleton Manchester, UK, M24 1XX
英国 曼彻斯特 格林赛得路 / 英國 曼徹斯特 格林賽得路

Follow link for Projector Documentation
Suivre le lien pour accéder à la documentation du projecteur
Produktdokumentation finden Sie unter dem Link
このページからQRコードを読み取ってプロジェクターのデータを取得してください
请扫描条码取得投影机的文件
프로젝터 설명서를 보려면 링크를 클릭하십시오

Manufacturers ID Label

LASER APERTURE
避免受到從本窗口射出的激光輻射的照射

LASER ENERGY : EXPOSURE NEAR APERTURE MAY CAUSE BURNS

Laser Aperture Label

WARNING
DO NOT LOOK INTO LENS
注意: 高亮, 请勿注视镜头

Laser Warning Label

CLASS 1 / RG3 Laser Product
Warning! Do not look into the beam.
No direct exposure to beam is permitted.
CLASS 1 BS EN IEC 60825-1:2014
RG3 BS EN IEC 62471-5:2015
Hazard Distance : Refer to Manual
Not for Household Use
CLASSE 1 / RG3 Laser Produit
Attention! Ne pas regarder dans le faisceau.
Pas d'exposition directe faisceau est autorisée.
CLASSE 1 BS EN IEC 60825-1:2014
RG3 BS EN IEC 62471-5:2015
Distance de danger : Se reporter au manuel
Pas à usage domestique

Light Hazard Explanatory Label

WARNING
ISOLATE MAINS BEFORE REMOVING COVER
注意: 打开前先切断主电源

Electrical Safety Label

**FIBRE INTERFACE
Refer to Manual**

Fibre Interface Label

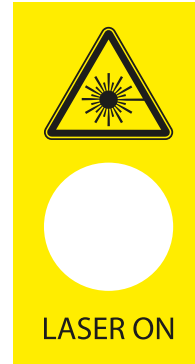

Laser On Hazard Indicator Label

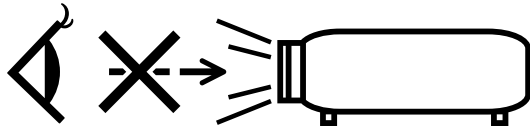

Laser Hazard Label



Lens Obstruction Hazard Label

This product is in conformity with performance standards for laser products under 21 CFR 1040, except with respect to those characteristics authorized by Variance Number 2021-V-0192 effective on March 20, 2021

FDA Laser Standards Conformity Label

Notes

Label Locations

1. Location of the Laser Hazard Label on the front of the Satellite Head.
2. Location of the Laser Warning Label on the front of the Satellite Head.
3. Location of the Laser On Hazard Indicator Label on the front of the Satellite Head.
4. Location of the Lens Obstruction Hazard Label on the front of the Satellite Head.
5. Location of the Laser Aperture Label on the front of the Satellite Head.
6. Location of the Fiber Interface Label on the rear of the Satellite Head.
7. Location of the Light Hazard Explanatory Label and the FDA Standards Conformity Label on the rear of the Satellite Head.

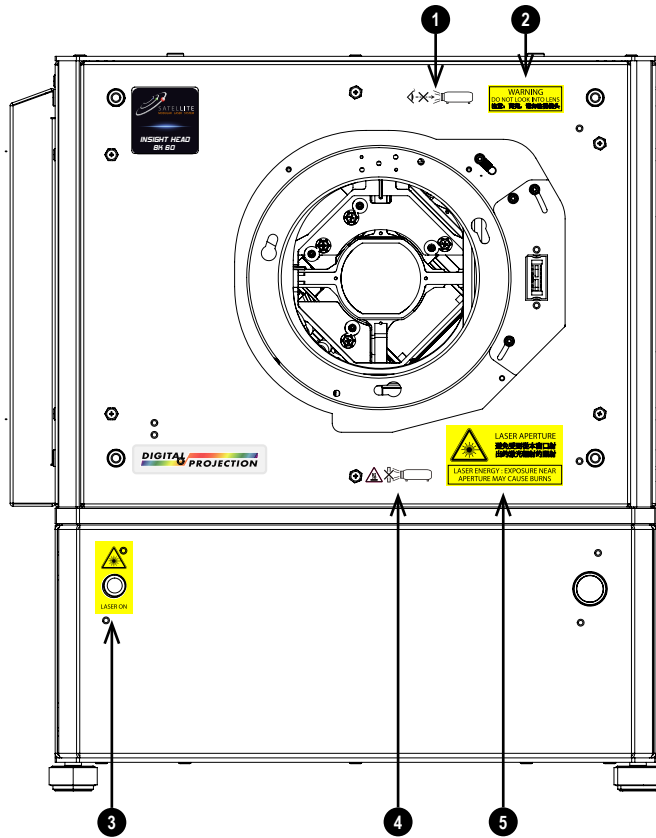

Satellite Head Front

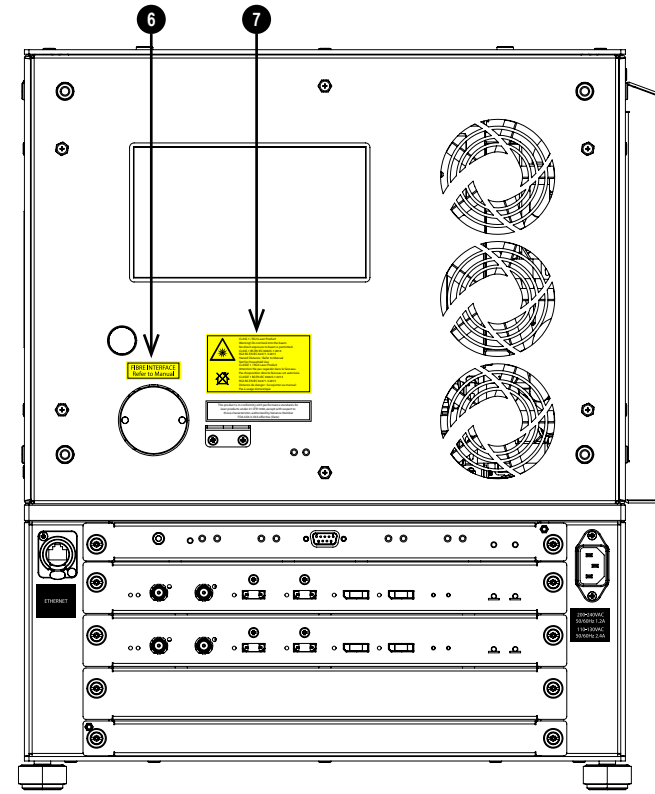

Satellite Head Rear

Notes

- 9. Location of the Manufacturer's ID Label on the left side of the Satellite Head.
- 10. Location of the Electrical Safety Label on the bottom of the Satellite Head.

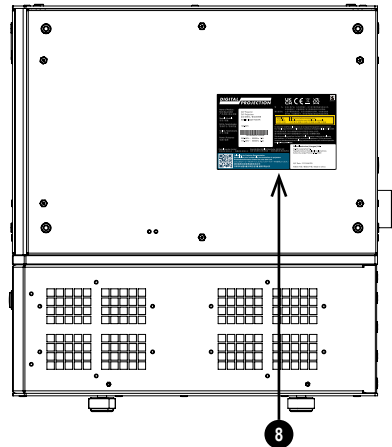

Satellite Head Left Side

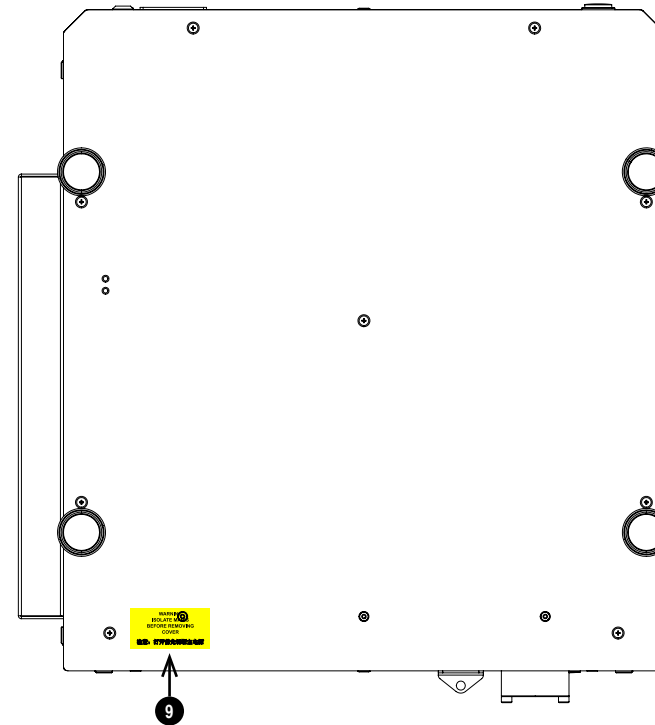

Satellite Head Bottom

Notes

Modular Light Source

		<p>此为A级产品，在生活环境中，该产品可能会造成无线电干扰。在这种情况下，可能需要用户对于此类采取可移动的措施。</p> <p>警告使用者：这是甲类的资讯产品。在原住的环境中使用时，可能会造成射频干扰。在这种情况下，使用者会被要求采取某些适当的对策。</p>
<p>Name of Product: Nom du produit: 产品名称/产品名稱:</p>	<p>Laser Light Module Module De Lumière Laser 激光光源模块 / 雷射光源模组</p>	<p>WARNING Isolate mains before removing cover. ATTENTION Isolez les conduites avant d'enlever le couvercle. 注意/注意 打开前先切断主电源/打開前先切斷主電源</p>
<p>Model / Modèle 型号/型號</p>	<p>MLS 10000</p>	<p>To reduce the risk of fire or electric shock, do not expose this equipment to rain or moisture. Pour réduire le risque d'incendie ou d'électrocution, n'exposez pas cet équipement à la pluie ou à l'humidité. 請勿將投影機置于雨中或潮濕環境中以降低起火或電擊的風險。</p>
<p>Part No. / Numéro de pièce 零件号/零件號</p>	<p>122-004X</p>	<p>This device complies with Part 15 of the FCC Rules. Operation is subject to the following two conditions: (1) This device may not cause harmful interference. (2) This device must accept any interference received, including interference that may cause undesired operation. CAN ICES-003(A) / NMB-003(A)</p>
<p>Serial No. / Numéro de série 序号/序號</p>	<p>Code 39 or 128 for Serial No. "XXXXXXXXXXXX"</p>	<p>Delta Electronics (Jiangsu) Ltd. No.1688, Jiangning East Rd., Wujiang Economic and Technological Development Zone, Suzhou City, Jiangsu Province, P.R.C.215200</p>
<p>Power / Puissance 电源/電源</p>	<p>100-240V~ 50/60Hz 10.1-4.9A</p>	<p>M.F DATE: YYYYMM.DD</p>
<p>US LISTED UL E15916</p>	<p>UK CA CE E</p>	<p>Made in China Fabriqué en Chine 中國製造 / 中國製造</p>
<p>Digital Projection Limited 英國輝佳有限公司 / 英國輝佳有限公司</p>	<p>Greenside Way, Middleton Manchester, UK M24 1XX 英國曼徹斯特格林賽得路 / 英國曼徹斯特格林賽得路</p>	<p>Follow link for Projector Documentation Suivre le lien pour accéder à la documentation du projecteur Produkttdokumentation finden Sie unter dem Link このマニュアルページへアクセスしてプロジェクターのデータを取って下さい 请扫描条码取得投影机文件 프로젝터 설명서를 보려면 링크를 클릭하십시오</p>

Manufacturers ID Label - MLS 10000

		<p>此为A级产品，在生活环境中，该产品可能会造成无线电干扰。在这种情况下，可能需要用户对于此类采取可移动的措施。</p> <p>警告使用者：这是甲类的资讯产品。在原住的环境中使用时，可能会造成射频干扰。在这种情况下，使用者会被要求采取某些适当的对策。</p>
<p>Name of Product: Nom du produit: 产品名称/产品名稱:</p>	<p>Laser Light Module Module De Lumière Laser 激光光源模块 / 雷射光源模组</p>	<p>WARNING Isolate mains before removing cover. ATTENTION Isolez les conduites avant d'enlever le couvercle. 注意/注意 打开前先切断主电源/打開前先切斷主電源</p>
<p>Model / Modèle 型号/型號</p>	<p>MLS 20000</p>	<p>To reduce the risk of fire or electric shock, do not expose this equipment to rain or moisture. Pour réduire le risque d'incendie ou d'électrocution, n'exposez pas cet équipement à la pluie ou à l'humidité. 請勿將投影機置于雨中或潮濕環境中以降低起火或電擊的風險。</p>
<p>Part No. / Numéro de pièce 零件号/零件號</p>	<p>123-445A</p>	<p>This device complies with Part 15 of the FCC Rules. Operation is subject to the following two conditions: (1) This device may not cause harmful interference. (2) This device must accept any interference received, including interference that may cause undesired operation. CAN ICES-003(A) / NMB-003(A)</p>
<p>Serial No. / Numéro de série 序号/序號</p>	<p>Code 39 or 128 for Serial No. "YYYYYDHWYSSSS"</p>	<p>Delta Electronics (Jiangsu) Ltd. No.1688, Jiangning East Rd., Wujiang Economic and Technological Development Zone, Suzhou City, Jiangsu Province, P.R.C.215200</p>
<p>Power / Puissance 电源/電源</p>	<p>100-240V~ 50/60Hz 5.5-10.5A</p>	<p>M.F DATE: YYYYMM.DD</p>
<p>UK CA CE E</p>	<p>UK CA CE E</p>	<p>Made in China Fabriqué en Chine 中國製造 / 中國製造</p>
<p>Digital Projection Limited 英國輝佳有限公司 / 英國輝佳有限公司</p>	<p>Greenside Way, Middleton Manchester, UK M24 1XX 英國曼徹斯特格林賽得路 / 英國曼徹斯特格林賽得路</p>	<p>Follow link for Projector Documentation Suivre le lien pour accéder à la documentation du projecteur Produkttdokumentation finden Sie unter dem Link このマニュアルページへアクセスしてプロジェクターのデータを取って下さい 请扫描条码取得投影机文件</p>

Manufacturers ID Label - MLS 20000

DIGITAL PROJECTION UK CA CE

Name of Product: Laser Light Module
 Nom du produit: Module De Lumière Laser
 产品名称/產品名稱: 激光光源模块 / 雷射光源模组

Model / Modèle: MLS 30000
 型号/型號

Part No. / Numéro de pièce: 123-799A
 零部件号 / 零件編號

Serial No. / Numéro de série: 100-240V~ 50/60Hz 6.5-14.5A
 序号/序號

Power / Puissance: 100-240V~ 50/60Hz 6.5-14.5A
 电源 / 電源

Warning: 警告: 在居住环境中, 运行此设备可能造成无线干扰。
 警告使用者: 這是早期的資訊產品, 在居住的環境中使用時, 可能會造成射頻干擾, 在這種情況下, 使用者會被要求採取某些適當的對策。

Attention: 注意/注意 打開前先切斷主電源/打開前先切斷主電源

Delta Electronics (Jiangsu) Ltd.
 No.1688, Jiangning East Rd.,
 Wujiang Economic and Technological
 Development Zone,
 Suzhou City, Jiangsu Province, P.R.C.215200

M.F DATE: YYYYMM.DD

Made in China
 Fabriqué en Chine
 中國製造 / 中國製造

Manufacturers ID Label - MLS 30000

CLASS 1 / RG3 Laser Product
 Warning! Do not look Into the beam.
 No direct exposure to beam Is Permitted.
 CLASS 1 BS EN IEC 60825-1:2014
 RG3 BS EN IEC 62471-5:2015
 Hazard Distance : Refer to Manual
 Not for Household Use
 CLASSE 1 / RG3 Laser Produit
 Attention! Ne pas regarder dans le faisceau.
 Pas d'exposition directe faisceau est autorisée.
 CLASS 1 BS EN IEC 60825-1:2014
 RG3 BS EN IEC 62471-5:2015
 Distance de danger : Se reporter au manuel
 Pas à usage domestique

Light Hazard Explanatory Label

DANGER
CLASS 4 LASER LIGHT IF REMOVED
AVOID EYE OR SKIN EXPOSURE TO
DIRECT OR SCATTERED LIGHT

Laser Warning Label

WARNING
警告 / 警告
Has Compressor Inside
机台内部有压缩机
機台内部有壓縮機

During the transportation, the refrigerant inside the machine may be displaced due to the tilt. To avoid machine failure, before booting must let the machine place for 1 hour after transportation to allow the refrigerant to return to its original position.

搬运的过程中, 机台内部的冷媒会因为倾斜而位移, 故搬运后请让机台静置1小时让冷媒回复到原位, 才能开机使用, 避免造成机台故障。

搬運的過程中, 機台内部的冷媒會因為傾斜而位移, 故搬運後請讓機台靜置1小時讓冷媒回復到原位, 才能開機使用, 避免造成機台故障。

Not allowed to tilt and move the machine when it is power on.
 机台点亮运行过程中不允许倾斜和移动机器。
 機台點亮運行過程中不允許傾斜和移動機器。

Compressor Transportation Warning Label

Notes



Fibre Interface Label



Laser On Hazard Indicator Label

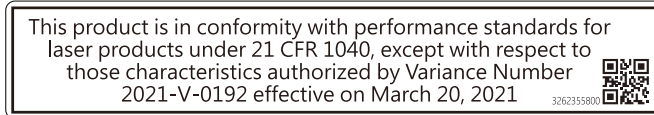

FDA Laser Standards Conformity Label

Notes

MLS 10000 Label Locations

1. Location of the Laser On Hazard Indicator Label on the front of the MLS.
2. Location of the Fiber Interface Label on the rear of the MLS.
3. Location of the FDA Standards Conformity Label on the rear of the MLS.
4. Location of the Light Hazard Explanatory Label on the rear of the MLS.

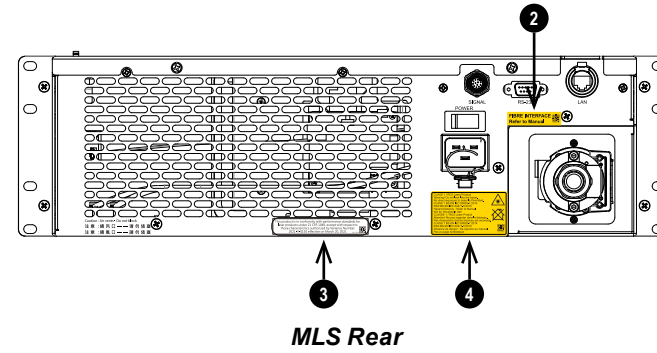
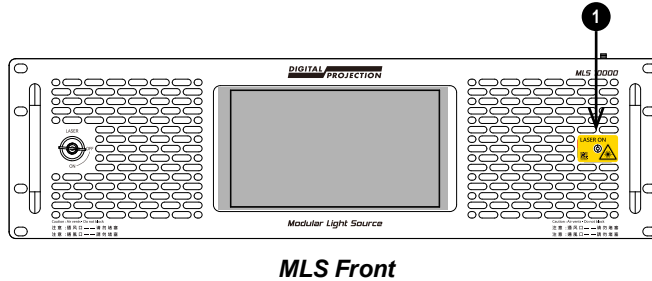

5. Location of the Manufacturer's ID Label on the left side of the MLS.
6. Location of the Internal Laser Warning Label inside the top cover of the MLS.

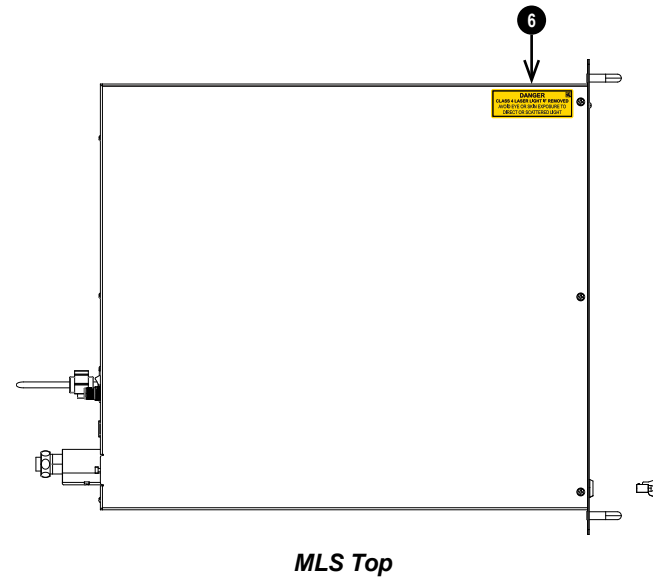
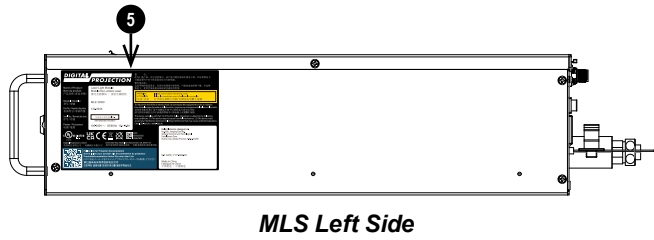

MLS 20000/MLS 30000 Label Locations

1. Location of the Laser On Hazard Indicator Label on the front of the MLS.
2. Location of the Fiber Interface Label on the rear of the MLS.
3. Location of the FDA Standards Conformity Label on the rear of the MLS.
4. Location of the Light Hazard Explanatory Label on the rear of the MLS.

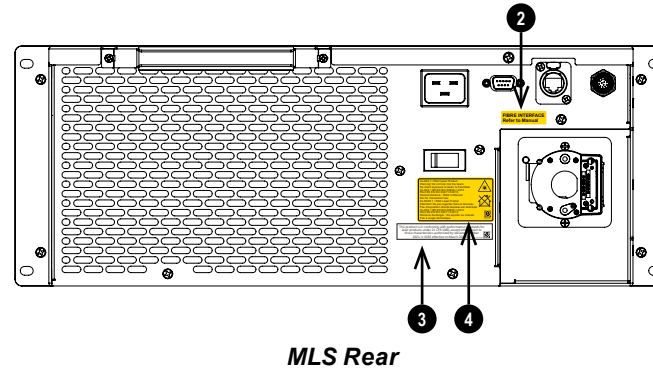
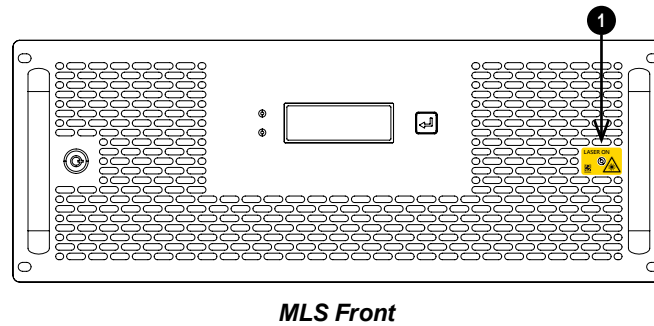

Notes

5. Location of the Manufacturer's ID Label on the left side of the MLS.
6. Location of the Compressor Transportation Warning on the left side of the MLS.
7. Location of the Internal Laser Warning Label on the top cover of the MLS.

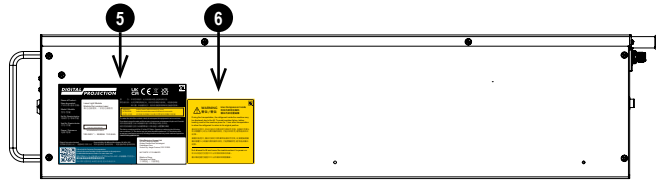

MLS Left Side

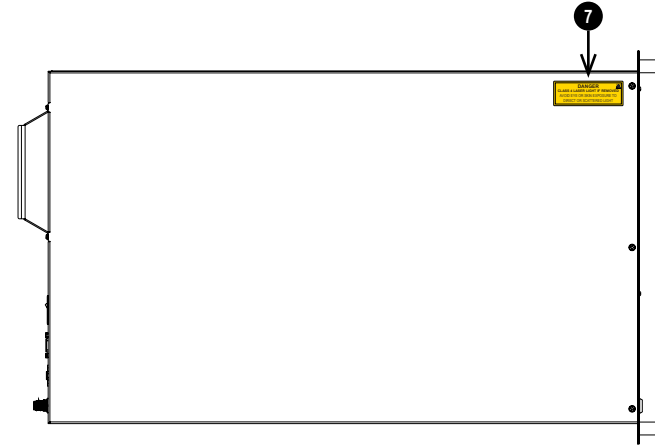

MLS Top

Notes

Satellite Control Module

DIGITAL PROJECTION

警告:
此为A级产品, 在生活环境中, 该产品可能会造成无线电干扰。在这种情况下, 可能需要用户对干扰采取切实可行的措施。

警告使用:
这是电场的敏感产品。在居住的环境中使用时, 可能会造成射频干扰。在这种情况下, 使用者会被要求采取某些适当的对策。

WARNING Isolate hands before removing cover.
ATTENTION Isoler les conduites avant d'enlever le couvercle.
注意/注意 打开前先切断主电源/打开前先切断主电源

Name of Product: System Control Module
Nom du produit: Module De Contrôle Du Système
产品名称/產品名稱: 系統控制模塊 / 系統控制模組

Model/ Modèle: Satellite Control Module
型号/型號

Part No. / Numéro de pièce: 122-143A
零件号/零件號

Serial No. / Numéro de série: "WYXXXXXXYYXXXX"
序号/序號

Power / Puissance: 100-240V~ 50/60Hz 0,4A
电源/電源

UL LISTED I.T.E. CE RoHS

Digital Projection Limited
英国纳佳有限公司 / 英國納佳有限公司
Greenside Way, Middleton Manchester, UK, M24 1XX
英國曼徹斯特格林賽得路 / 英國曼徹斯特格林賽得路

Delta Electronics (Jiangsu) Ltd.
No.1058, Jiangong East Rd,
Wujiang Economic and Technological
Development Zone,
Suzhou City, Jiangsu Province, P.R.C.215200

M.F DATE: YYYYMM.DD

Made in China
Fabriqué en Chine
中國製造 / 中國製造

Follow link for Projector Documentation
Suivre le lien pour accéder à la documentation du projecteur
Produktdokumentation finden Sie unter dem Link
この二次元バーコードをスキャンしてプロジェクターのデータを取得してください
請扫描条码采取取得投影机的相关文件
프로젝터 설명서를 보려면 링크를 클릭하십시오

Manufacturers ID Label



Laser On Hazard Indicator Label

Label Locations

1. Location of the Laser On Hazard Indicator Label on the front of the SCM.

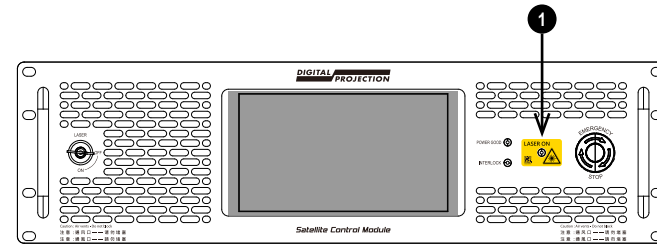

SCM Front

2. Location of the Manufacturer's ID Label on the left side of the SCM.

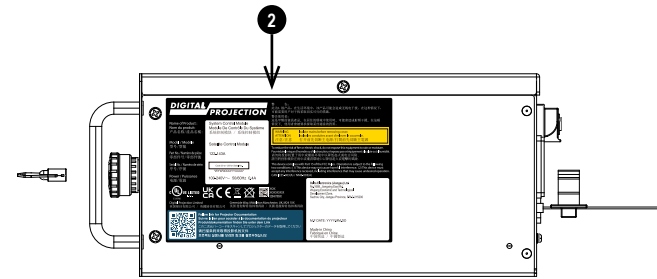

SCM Left Side

Notes

Satellite Link Cable

Notes



Manufacturers ID Label

Label Locations

1. Location of the Manufacturer's ID Label on the opposite sides of the SLC label tag.

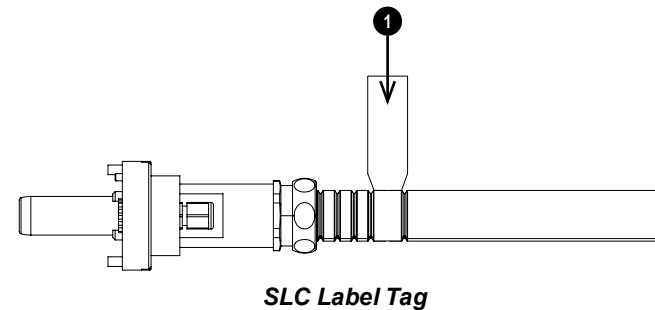

SLC Label Tag

Lens Hood

Lens Hood

1. Location of the Laser Warning Label on the lens hood

DANGER
CLASS 4 LASER LIGHT WHEN REMOVED
AVOID EYE OR SKIN EXPOSURE TO
DIRECT OR SCATTERED LIGHT

Laser Warning Label

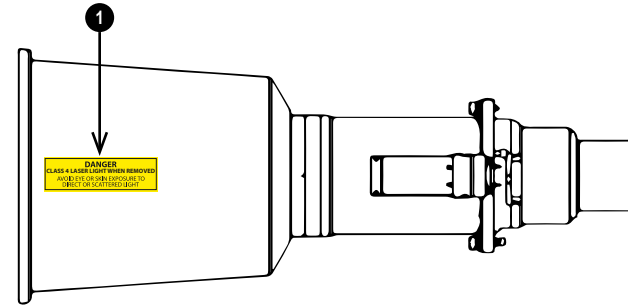

Notes

 The lens hood is supplied with the lens. It is pre-fitted to the 2.53 - 4.98 : 1 zoom lens (4K) or 2.70 - 5.31 : 1 zoom lens (8K) for use in the United States of America.

Appendix B: Choosing a lens

A number of lenses are available. Which lens you choose depends on the screen size, image aspect ratio, throw distance and light output.

The following table shows all available lenses in order of their throw ratios:

Full 4K Throw Ratios

Throw ratio	Lens extension	Lens shift	Optimized focus range	Part number
1.13 - 1.72 : 1 zoom	250.37 mm (9.86 in) 225 mm (8.9 in)	At 1.13:1 zoom: V: 0.340 (U) 0.190 (D) frame H: 0.09 (L) 0.09 (R) frame At 1.72:1 zoom: V: 0.500 (U) 0.190 (D) frame H: 0.16 (L) 0.16 (R) frame	2.5 m - 40+ m (8.2 ft - 130+ ft) at 1.13:1 0.5 m - 40+ m (1.6 ft - 130+ ft) at 1.72:1	115-627
1.65 - 2.60 : 1 zoom	219.62 mm (8.65 in) 195 mm (7.7 in)	At 1.65:1 zoom: V: 0.400 (U) 0.200 (D) frame H: 0.13 (L) 0.13 (R) frame At 2.60:1 zoom: V: 0.500 (U) 0.200 (D) frame H: 0.17 (L) 0.17 (R) frame	3.5 m - 40+ m (11.5 ft - 130+ ft) at 1.65:1 1.0 m - 40+ m (3.3 ft - 130+ ft) at 2.60:1	115-630
2.53 - 4.98 : 1 zoom	219.55 mm (8.64 in) 195 mm (7.7 in)	At 2.53:1 zoom: V: 0.375 (U) 0.200 (D) frame H: 0.13 (L) 0.13 (R) frame At 4.98:1 zoom: V: 0.500 (U) 0.195 (D) frame H: 0.16 (L) 0.16 (R) frame V: 0.42 (U) 0.20 (D) frame H: 0.13 (L) 0.17 (R) frame	1.5 m - 40+ m (4.9 ft - 130+ ft) at 2.53:1 4.5 m - 40+ m (14.8 ft - 130+ ft) at 4.98:1	115-632

4K UHD or 8K Throw Ratios

Throw ratio	Lens extension	Lens shift	Optimized focus range	Part number
1.21 - 1.83 : 1 zoom	250.37 mm (9.86 in) 225 mm (8.9 in)	V: 0.40 (U) 0.20 (D) frame H: 0.08 (L) 0.14 (R) frame	V: 0.40 (U) 0.20 (D) frame H: 0.08 (L) 0.14 (R) frame	115-627
1.76 - 2.77 : 1 zoom	219.62 mm (8.65 in) 195 mm (7.7 in)	V: 0.45 (U) 0.20 (D) frame H: 0.13 (L) 0.17 (R) frame	3.5 m - 40+ m (11.5 ft - 130+ ft)	115-630
2.70 - 5.31 : 1 zoom	219.55 mm (8.64 in) 195 mm (7.7 in)	V: 0.42 (U) 0.20 (D) frame H: 0.13 (L) 0.17 (R) frame	4.5 m - 40+ m (14.8 ft - 130+ ft)	115-632

To choose a lens, calculate the **throw ratio** required. Allow a tolerance of +/- 3% in the throw ratio calculation.

Notes

Throw distance calculations are based on the distance from the outer end of the lens, which varies from lens to lens.

The lens extension is the distance between the front of the projector chassis and the outer end of the lens when it is fully extended.

Refer to the projector CAD drawings for individual lens extension figures.

See Fitting a lens hood on page 41 for more information about using the right lens and hood

Basic calculation

Identify the required lens by calculating the **throw ratio**.

A **throw ratio** is the ratio of the throw distance **2** to the screen width **1**:

$$\text{ThrowRatio} = \text{ThrowDistance} / \text{ScreenWidth}$$

1. Use the formula above to obtain the required throw ratio.
2. Allow a tolerance of +/- 3% in the throw ratio calculation and match the throw ratio with a lens from the table below:

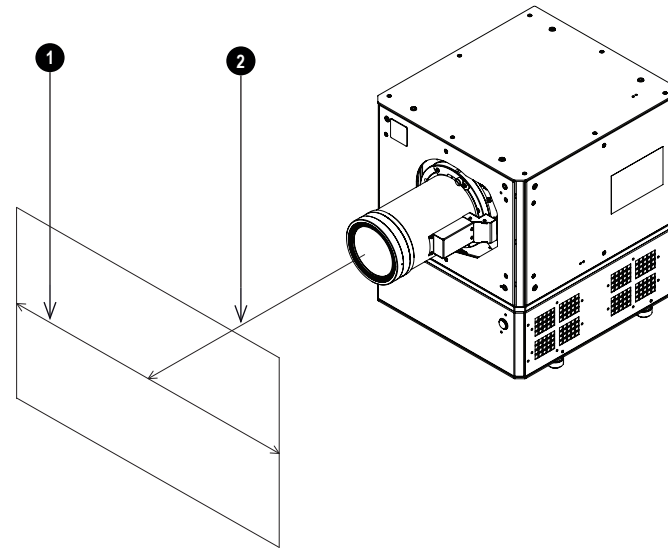

Notes

The basic calculation on this page does not take into consideration DMD™ and image size, which could affect the throw ratio. See Full lens calculation on page 166 for a more complex and realistic calculation.

When calculating the throw ratio, be sure to use identical measurement units for both the throw distance and the screen width.

See Choosing a lens on the previous page for information about individual lens part numbers

See Fitting a lens hood on page 41 for more information about using the right lens and hood

Full 4K Throw Ratios

Throw ratio	Optimized focus range
1.13 - 1.72 : 1 zoom	2.5 m - 40+ m (8.2 ft - 130+ ft) at 1.13:1 0.5 m - 40+ m (1.6 ft - 130+ ft) at 1.72:1
1.65 - 2.60 : 1 zoom	3.5 m - 40+ m (11.5 ft - 130+ ft) at 1.65:1 1.0 m - 40+ m (3.3 ft - 130+ ft) at 2.60:1
2.53 - 4.98 : 1 zoom	1.5 m - 40+ m (4.9 ft - 130+ ft) at 2.53:1 4.5 m - 40+ m (14.8 ft - 130+ ft) at 4.98:1

4K UHD or 8K Throw Ratios

Throw ratio	Optimized focus range
1.21 - 1.83 : 1 zoom	V: 0.40 (U) 0.20 (D) frame H: 0.08 (L) 0.14 (R) frame
1.76 - 2.77 : 1 zoom	3.5 m - 40+ m (11.5 ft - 130+ ft)
2.70 - 5.31 : 1 zoom	4.5 m - 40+ m (14.8 ft - 130+ ft)

3. Ensure the required throw distance is within the range covered by the lens.

Basic calculation example

1. Calculate the throw ratio using the formula.
Your screen is **4.5m** wide and you wish to place the projector approximately **11m** from the screen. The throw ratio will then be
 $11 \div 4.5 = \mathbf{2.44}$
2. Match the result with the lens table.
The lens matching a throw ratio of 2.44 is the **1.65 : 2.60 : 1 zoom**.
3. Check whether the lens covers the required throw distance.
The focus range quoted for the 1.65 : 2.60 : 1 zoom lens is **1 - 100m**. The required distance of 11m is within the range.

INFORMATION YOU NEED FOR THIS CALCULATION

The throw ratio formula:

$$\mathbf{ThrowRatio = ThrowDistance / ScreenWidth}$$

Allow a tolerance of +/- 3% in the throw ratio calculation.

The lens table:

Full 4K Throw Ratios

Throw ratio	Optimized focus range
1.13 - 1.72 : 1 zoom	2.5 m - 40+ m (8.2 ft - 130+ ft) at 1.13:1 0.5 m - 40+ m (1.6 ft - 130+ ft) at 1.72:1
1.65 - 2.60 : 1 zoom	3.5 m - 40+ m (11.5 ft - 130+ ft) at 1.65:1 1.0 m - 40+ m (3.3 ft - 130+ ft) at 2.60:1
2.53 - 4.98 : 1 zoom	1.5 m - 40+ m (4.9 ft - 130+ ft) at 2.53:1 4.5 m - 40+ m (14.8 ft - 130+ ft) at 4.98:1

4K UHD or 8K Throw Ratios

Throw ratio	Optimized focus range
1.21 - 1.83 : 1 zoom	V: 0.40 (U) 0.20 (D) frame H: 0.08 (L) 0.14 (R) frame
1.76 - 2.77 : 1 zoom	3.5 m - 40+ m (11.5 ft - 130+ ft)
2.70 - 5.31 : 1 zoom	4.5 m - 40+ m (14.8 ft - 130+ ft)

Notes

 The basic calculation on this page does not take into consideration DMD™ and image size, which could affect the throw ratio. See Full lens calculation on the next page for a more complex and realistic calculation.

 See Choosing a lens on page 163 for information about individual lens part numbers.

Full lens calculation

Introducing TRC

The choice of lens will affect the image size and will address discrepancies between the DMD™ resolution and the source.

When an image fills the height of the DMD™ but not the width, it uses less than 100% of the DMD™ surface. A lens chosen using the basic formula may produce an image that is considerably smaller than the actual screen.

To compensate for loss of screen space in such situations, you need to increase the throw ratio using a **Throw Ratio Correction (TRC)**.

Example

Fig. 1 illustrates a 4:3 image within a 16:9 display

When a 16:9 projector is used for a 4:3 image, the image does not fill the width of the DMD™, creating a **pillarboxing** effect - blank spaces to the left and right.

Fig. 2 shows the same image projected on a 4:3 screen using a standard lens (chosen with the basic calculation).

The DMD™ accurately fills the width of the screen; however, the pillarboxing is now part of the projected image and is transferred to the screen.

The DMD™ does not fill the height of the screen, which has caused **letterboxing** - further blank spaces at the top and bottom of the screen.

The image is now surrounded by blank space, which can be removed if the throw ratio is increased.

Fig. 3 shows the image projected on the same screen with a lens chosen using TRC. The increased throw ratio has allowed the 4:3 image to fill the 4:3 screen seamlessly



Fig 1

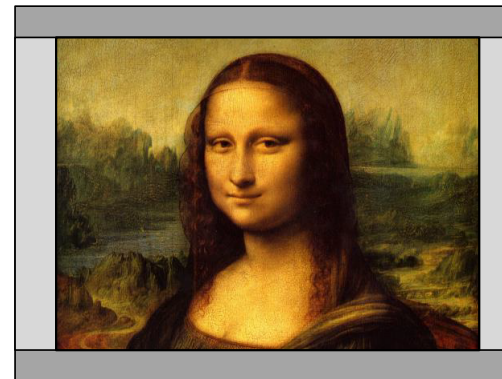



Fig 2



Fig 3

Notes

 TRC can only be applied if greater than 1. If TRC is 1 or less, disregard it and calculate the throw ratio using the basic formula.

Calculating TRC

To calculate TRC, use the following formula:

$$TRC = 1.78(DMD^{\text{TM}} \text{ AspectRatio}) / \text{Source AspectRatio}.$$

TRC table

Alternatively, you can save time by referencing the following table, which shows the TRC value for some popular image formats:

2.35:1 (Scope)

1.85:1 (Flat)

1.78:1 (16:9)

1.66:1 (Vista)

1.6:1 (16:10)

1.33:1 (4:3)

1.25:1 (5:4)

Calculating the throw ratio with TRC

- For TRC > 1, amend the basic throw ratio formula as follows:

$$\text{ThrowRatio} = \text{ThrowDistance} / \text{ScreenWidth} * TRC$$

Allow a tolerance of +/- 3% in the throw ratio calculation.

- Once a throw ratio is established, identify the matching lens from the table:

Full 4K Throw Ratios

Throw ratio	Optimized focus range
1.13 - 1.72 : 1 zoom	2.5 m - 40+ m (8.2 ft - 130+ ft) at 1.13:1 0.5 m - 40+ m (1.6 ft - 130+ ft) at 1.72:1
1.65 - 2.60 : 1 zoom	3.5 m - 40+ m (11.5 ft - 130+ ft) at 1.65:1 1.0 m - 40+ m (3.3 ft - 130+ ft) at 2.60:1
2.53 - 4.98 : 1 zoom	1.5 m - 40+ m (4.9 ft - 130+ ft) at 2.53:1 4.5 m - 40+ m (14.8 ft - 130+ ft) at 4.98:1

4K UHD or 8K Throw Ratios

Throw ratio	Optimized focus range
1.21 - 1.83 : 1 zoom	V: 0.40 (U) 0.20 (D) frame H: 0.08 (L) 0.14 (R) frame
1.76 - 2.77 : 1 zoom	3.5 m - 40+ m (11.5 ft - 130+ ft)
2.70 - 5.31 : 1 zoom	4.5 m - 40+ m (14.8 ft - 130+ ft)

- Ensure the required throw distance is within the range of the matching lens.

Notes



TRC can only be applied if greater than 1. If TRC is 1 or less, disregard it and calculate the throw ratio using the basic formula.



Throw ratio for sources with a width of 3840 will be as the 4K-UHD ratio on the lens table.



TRC can only be applied if greater than 1. If TRC is 1 or less, disregard it and calculate the throw ratio using the basic formula.



See Fitting a lens hood on page 41 for more information about using the right lens and hood.

Full lens calculation example

Your screen is **4.5m** wide; you wish to place the projector approximately **11m** from the screen. The source is **4:3**.

1. Calculate TRC as follows:
TRC = 1.78 / 1.33 = 1.34.
2. Calculate the throw ratio:
Throw ratio = 11 / 4.5 x 1.34 = **3.28**
3. Allow a tolerance of +/- 3% in the throw ratio calculation and find a match in the lens table.
The table shows that the matching lens is **the 2.53 - 4.98 : 1 zoom lens**.
4. Check whether the lens covers the required throw distance.
The focus range quoted for the 2.53 - 4.98 : 1 zoom lens is **4.5m - 100m**. The required distance of 11 m is within the range.

INFORMATION YOU NEED FOR THESE CALCULATIONS

The TRC formula

$$TRC = DMD^{TM} \text{ AspectRatio} / \text{Source AspectRatio}$$

The TRC table (to use instead of the formula)

- 2.35:1 (Scope)** TRC not used
- 1.85:1 (Flat)** TRC not used
- 1.78:1 (16:9)** TRC not used (native aspect ratio)
- 1.66:1 (Vista)** TRC = 1.07
- 1.6:1 (16:10)** TRC = 1.11
- 1.33:1 (4:3)** TRC = 1.33
- 1.25:1 (5:4)** TRC = 1.42

The throw ratio formula

$$ThrowRatio = ThrowDistance / ScreenWidth * TRC$$

Allow a tolerance of +/- 3% in the throw ratio calculation.

The lens table:

Full 4K Throw Ratios

Throw ratio	Optimized focus range
1.13 - 1.72 : 1 zoom	2.5 m - 40+ m (8.2 ft - 130+ ft) at 1.13:1 0.5 m - 40+ m (1.6 ft - 130+ ft) at 1.72:1
1.65 - 2.60 : 1 zoom	3.5 m - 40+ m (11.5 ft - 130+ ft) at 1.65:1 1.0 m - 40+ m (3.3 ft - 130+ ft) at 2.60:1
2.53 - 4.98 : 1 zoom	1.5 m - 40+ m (4.9 ft - 130+ ft) at 2.53:1 4.5 m - 40+ m (14.8 ft - 130+ ft) at 4.98:1

4K UHD or 8K Throw Ratios

Throw ratio	Optimized focus range
1.21 - 1.83 : 1 zoom	V: 0.40 (U) 0.20 (D) frame H: 0.08 (L) 0.14 (R) frame
1.76 - 2.77 : 1 zoom	3.5 m - 40+ m (11.5 ft - 130+ ft)
2.70 - 5.31 : 1 zoom	4.5 m - 40+ m (14.8 ft - 130+ ft)

Notes

Appendix C: Positioning the image

The normal position for the projector is at the center of the screen. However, you can set the projector above or below the center, or to one side, and adjust the image using the **Lens shift** feature (known as **rising and falling front**) to maintain a geometrically correct image.

Any single adjustment outside the ranges specified on the following page may result in an unacceptable level of distortion, particularly at the corners of the image, due to the image passing through the periphery of the lens optics.

If the lens is to be shifted in two directions combined, the maximum range without distortion will be somewhat less, as can be seen in the illustrations.

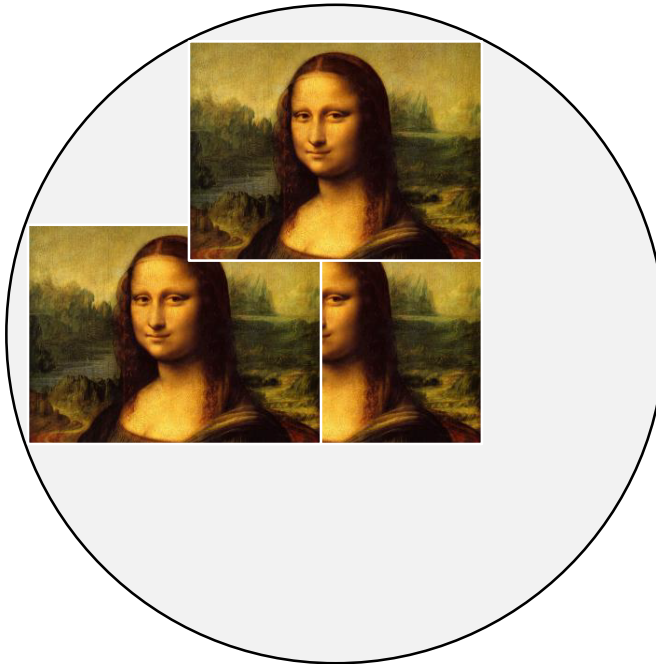

Full horizontal or vertical shift

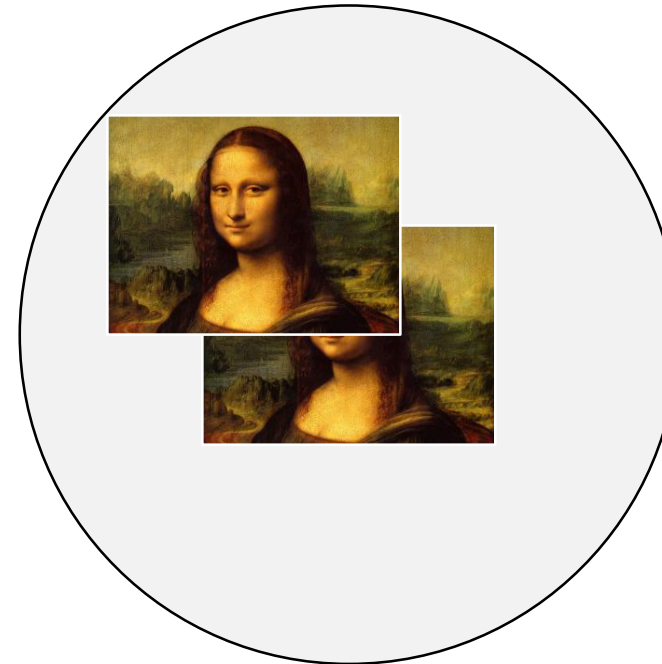

Combined shift is reduced

Notes



Whenever possible, position the projector so that the lens is centered for the highest quality image

Appendix D: Supported signal input modes

2D formats

Input	Input Description	Input Frame Rate	Dark Time us	Frame Rate Multiplier	Frame rate at output of each ICP120	Displayed Frame Rate 4K	Displayed Frame Rate 8K
HDMI A (Slot 1 only) UHD (3840 x 2160)		23.98	N/A	N/A	23.98	23.98	
		24	N/A	N/A	24	24	
		25	N/A	N/A	25	25	
		29.97	N/A	N/A	29.97	29.97	
		30	N/A	N/A	30	30	
		48	N/A	N/A	48	48	
		50	N/A	N/A	50	50	
		59.94	N/A	N/A	59.94	59.94	
		59.94	7000	N/A	59.94	59.94	
		60	N/A	N/A	60	60	
		60	7000	N/A	60	60	
	(2k input)	96	N/A	N/A	96	96	
	(2k input)	100	N/A	N/A	100	100	
(2k input)	120	N/A	N/A	120	120		
HDMI B (Slot 1 only) UHD (3840 x 2160)		23.98	N/A	N/A	23.98	23.98	
		24	N/A	N/A	24	24	
		25	N/A	N/A	25	25	
		29.97	N/A	N/A	29.97	29.97	
		30	N/A	N/A	30	30	
		48	N/A	N/A	48	48	
		50	N/A	N/A	50	50	
		59.94	N/A	N/A	59.94	59.94	
		59.94	7000	N/A	59.94	59.94	
		60	N/A	N/A	60	60	
		60	7000	N/A	60	60	
	(2k input)	96	N/A	N/A	96	96	
	(2k input)	100	N/A	N/A	100	100	
(2k input)	120	N/A	N/A	120	120		

Notes



DisplayPort and HDMI receivers will accept Deep-Color and higher bit depth sources inline with DP1.2 and HDMI standards. Insight processing is carried out at up to 12bits per color (RGB in gamma space) and maps to a displayed palette of 16 bits per color (linear space).



DisplayPort Higher frame rate input formats of up to 2048x1080 at up to 120Hz can be accepted. These can be scaled 2:1 to best fit the DMD™. Formats above this resolution can have a maximum input frame rate up to 60 frames per second and multiplied in the formatter for 3D.



Input frame rates of 24, 30, 50 and 60 frames per second are nominal. The system also accepts at least 23.98, 25, 48 and 59.94 frames per second.



The Frame Rate Multiplier function is not available within the OSD. It is only available over protocol. The default value is x1.

Input	Input Description	Input Frame Rate	Dark Time us	Frame Rate Multiplier	Frame rate at output of each ICP120	Displayed Frame Rate 4K	Displayed Frame Rate 8K	Notes
Display Port 1.2 A (Slot 1 only) UHD (3840 x 2160)		23.98	N/A	N/A	23.98	23.98		
		24	N/A	N/A	24	24		
		25	N/A	N/A	25	25		
		29.97	N/A	N/A	29.97	29.97		
		30	N/A	N/A	30	30		
		48	N/A	N/A	48	48		
		50	N/A	N/A	50	50		
		59.94	N/A	N/A	59.94	59.94		
		59.94	7000	N/A	59.94	59.94		
		60	N/A	N/A	60	60		
		60	7000	N/A	60	60		
	(2k input)	96	N/A	N/A	96	96		
	(2k input)	100	N/A	N/A	100	100		
(2k input)	120	N/A	N/A	120	120			
Display Port 1.2 B (Slot 1 only) UHD (3840 x 2160)		23.98	N/A	N/A	23.98	23.98		
		24	N/A	N/A	24	24		
		25	N/A	N/A	25	25		
		29.97	N/A	N/A	29.97	29.97		
		30	N/A	N/A	30	30		
		48	N/A	N/A	48	48		
		50	N/A	N/A	50	50		
		59.94	N/A	N/A	59.94	59.94		
		59.94	7000	N/A	59.94	59.94		
		60	N/A	N/A	60	60		
		60	7000	N/A	60	60		
	(2k input)	96	N/A	N/A	96	96		
	(2k input)	100	N/A	N/A	100	100		
(2k input)	120	N/A	N/A	120	120			
Display Port 1.2 A+B LR (Slot 1 only) UHD (3840 x 2160)		2 x 25	N/A	N/A	50	50		
		2 x 30	N/A	N/A	60	60		
		2 x 50	N/A	N/A	100	100		
		2 x 59.94	N/A	N/A	119.92	119.92		
		2 x 60	N/A	N/A	120	120		
Display Port 1.2 A+B EW (Slot 1 only) UHD 2x(1920 x 2160)		2 x 60	N/A	N/A	60	60		
		2 x 120	N/A	N/A	120	120		

Input	Input Description	Input Frame Rate	Dark Time us	Frame Rate Multiplier	Frame rate at output of each ICP120	Displayed Frame Rate 4K	Displayed Frame Rate 8K	Notes
Display Port A+B + C+D8K (Slot 1 + Slot 2) 8K (7680 x 4320)		4 x 24	N/A	2	96	192	48	
		4 x 25	N/A	2	100	200	50	
		4 x 30	N/A	2	60	240	60	
		4 x 48	N/A	N/A	96	192	48	
		4 x 50	N/A	N/A	100	200	50	
		4 x 60	N/A	N/A	120	240	60	
		4 x 60	N/A	N/A	120	240	60	

3D formats

Input	Input Description	Input Frame Rate	Dark Time us	Frame Rate Multiplier	Frame rate at output of each ICP120	Displayed Frame Rate 4K
HDMI A (Slot 1 only) UHD (3840 x 2160)		24 Frame Packed	500	3	48	144
		24 Frame Packed	1000	3	48	144
		24 Frame Packed	1500	3	48	144
	(2k input)	120	500	N/A	120	120
	(2k input)	120	1000	N/A	120	120
	(2k input)	120	1500	N/A	120	120
HDMI B (Slot 1 only) UHD (3840 x 2160)		24 Frame Packed	500	3	48	144
		24 Frame Packed	1000	3	48	144
		24 Frame Packed	1500	3	48	144
	(2k input)	120	500	N/A	120	120
	(2k input)	120	1000	N/A	120	120
	(2k input)	120	1500	N/A	120	120
Display Port 1.2 A (Slot 1 only) UHD (3840 x 2160)	(2k input)	120	500	N/A	120	120
	(2k input)	120	1000	N/A	120	120
	(2k input)	120	1500	N/A	120	120
Display Port 1.2 B (Slot 1 only) UHD (3840 x 2160)	(2k input)	120	500	N/A	120	120
	(2k input)	120	1000	N/A	120	120
	(2k input)	120	1500	N/A	120	120
Display Port 1.2 A+B LR (Slot 1 only) UHD (3840 x 2160)		2 x 24	500	3	48	144
		2 x 24	1000	3	48	144
		2 x 24	1500	3	48	144
		2 x 60	500	N/A	120	120
		2 x 60	1000	N/A	120	120
		2 x 60	1500	N/A	120	120

Notes

 DisplayPort Higher frame rate input formats of up to 2048x1080 at up to 120Hz can be accepted. These can be scaled 2:1 to best fit the DMD™. Formats above this resolution can have a maximum input frame rate up to 60 frames per second and multiplied in the formatter for 3D.

 Input frame rates of 24, 30, 50 and 60 frames per second are nominal. The system also accepts at least 23.98, 25, 48 and 59.94 frames per second.

 Frame sequential is accepted for 2K and 4K sources. Frame packing, Top/Bottom and Side-by-Side formats are accepted for sources up to 1080p resolutions.

Appendix E: How 8K is Processed

Four 4K Pixel Planes (Sub Frames) are sent from the media server, to four Display Port inputs on the Satellite Head:

- Display Port A Slot 1
- Display Port B Slot 1
- Display Port A Slot 2
- Display Port B Slot 2

The output from the projector uses alternate pixel packing.
This combines four 4K pixel planes to produce the 8K image.
The output sequence is cyclic:

1. 4k sub-F1 → Slot 1 Display Port-A
2. 4k sub-F2 → Slot 1 Display Port-B
3. 4k sub-F3 → Slot 2 Display Port-B
4. 4k sub-F4 → Slot 2 Display Port-A

Here is the connector layout showing the 4K Pixel Planes (Sub Frames) labels:

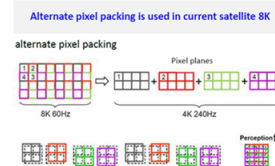
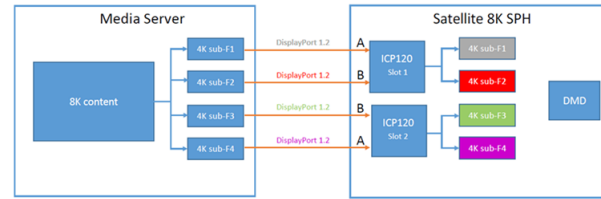

Notes

See 8K alternate pixel packing on page 76 for guidance on connecting to the Satellite Head for 8K.

Appendix F: Wiring details

Signal inputs and outputs

HDMI

19 way type A connector

1. TMDS Data 2+
2. TMDS Data 2 Shield (Ground)
3. TMDS Data 2-
4. TMDS Data 1+
5. TMDS Data 1 Shield (Ground)
6. TMDS Data 1-
7. TMDS Data 0+
8. TMDS Data 0 Shield (Ground)
9. TMDS Data 0-
10. TMDS Clock+
11. TMDS Clock Shield (Ground)
12. TMDS Clock-
13. CEC
14. not connected
15. SCL (DDC Clock)
16. SCA (DDC Data)
17. DDC/CEC Shield (Ground)
18. +5 V Power
19. Hot Plug Detect

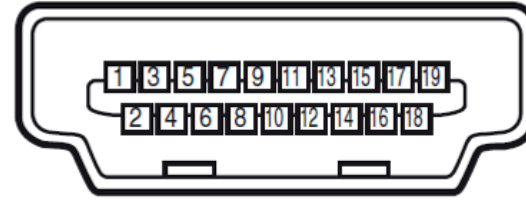

HDMI: pin view of panel connector

Notes

DisplayPort

DisplayPort 1.2

Pin 1	ML_Lane 0 (p)	Lane 0 (positive)
Pin 2	GND	Ground
Pin 3	ML_Lane 0 (n)	Lane 0 (negative)
Pin 4	ML_Lane 1 (p)	Lane 1 (positive)
Pin 5	GND	Ground
Pin 6	ML_Lane 1 (n)	Lane 1 (negative)
Pin 7	ML_Lane 2 (p)	Lane 2 (positive)
Pin 8	GND	Ground
Pin 9	ML_Lane 2 (n)	Lane 2 (negative)
Pin 10	ML_Lane 3 (p)	Lane 3 (positive)
Pin 11	GND	Ground
Pin 12	ML_Lane 3 (n)	Lane 3 (negative)
Pin 13	CONFIG1	Connected to Ground1
Pin 14	CONFIG2	Connected to Ground1
Pin 15	AUX CH (p)	Auxiliary Channel (positive)
Pin 16	GND	Ground
Pin 17	AUX CH (n)	Auxiliary Channel (negative)
Pin 18	Hot Plug	Hot Plug Detect
Pin 19	Return	Return for Power
Pin 20	DP_PWR	Power for connector (3.3 V 500 mA)

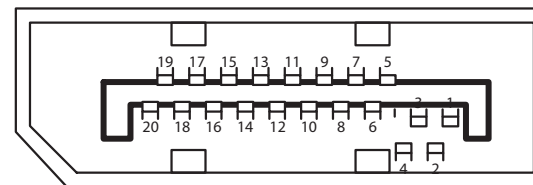

DisplayPort: pin view of panel connector

Notes

Control connections

LAN

RJ45 socket

1. TX+
2. TX-
3. TXC
4. Ground
5. Ground
6. RXC
7. RX+
8. RX-

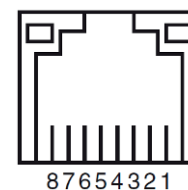

LAN: pin view of panel connector

 Only one remote connection (RS232 or LAN) should be used at any one time.

RS232

9 way D-type connector

1. not connected
2. Received Data (RX)
3. Transmitted Data (TX)
4. not connected
5. Ground
6. not connected
7. Short with pin8
8. Short with pin7
9. not connected

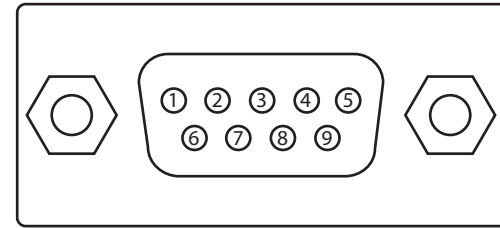

RS232: pin view of panel male connector

Notes

Trigger

3.5 mm mini jack, Output: 12V, 200 mA max

- **Tip** Signal
- **Sleeve** Ground

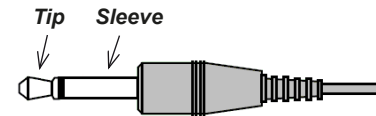

Appendix G: Cleaning the SLC

Repeated installations and device changes may expose the surface of the optical fiber in the SLC to dirt and other contaminants.

Prolonged use of a contaminated SLC may damage the SLC. It is important to clean the SLC to maintain the performance of the SLC.

The SLC connectors should be cleaned every time they are connected to a device.

The basics of cleaning:

1. Use a pure grade of isopropyl alcohol on a clean lint-free tissue to wipe the end face of the SLC and the connector.
2. Wipe the surfaces with a dry lint-free tissue. Do not allow the surface to air dry.
3. Inspect the connector to make sure it is clean. Repeat cleaning if necessary.

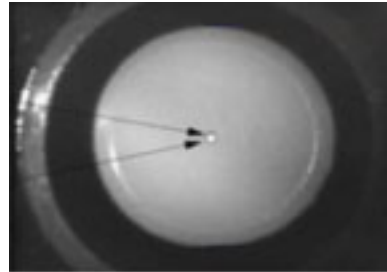

Example of a clean SLC

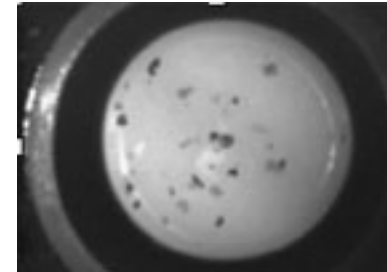



Example of a dirty SLC



Example of a damaged SLC

Notes

 You can use a 100x illuminated microscope (fiberscope) to inspect the connector.

 Contact a Digital Projection service center for further information on cleaning and cleaning products.

Appendix H: Served web pages

The served web pages allow you to control the system remotely via Ethernet. The controls replicate some or all of the functions available in the OSD, or the touchscreen control panels on each Satellite module.

The device you use to access the served web pages must be connected to the same network as the SCM. Use a web browser to access the served web pages.

The default IP address is **192.168.0.100**.

The home page for the served web pages is the system configuration page. Use this page to access the controls for each individual module:

- The system controller menu provides access to the controls on the SCM touchscreen.
- **Component 1, Component 2, Component 3, Component 4, Component 5.** Each component menu provides information about the other modules installed in the system. This could be 1-4 MLS and 1 Satellite Head or 1 MLS and 1-4 Satellite Heads. Click the menu icon in the header to enable the link to the component menus. Click on a component menu open its touchscreen menus and access various settings.

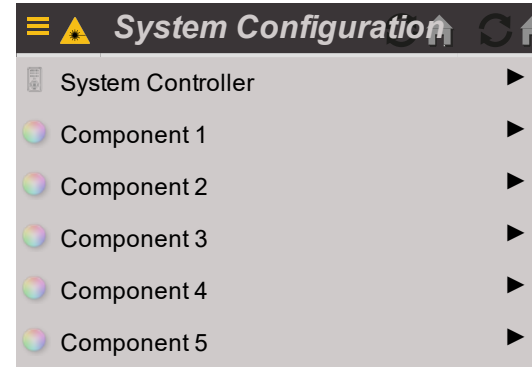

Web Served Screen Display: Top Level Menu

A Satellite Head component menu provides access to the controls on the Satellite Head touchscreen.

Refer to the operating guide for the Satellite Head for guidance on using the menus. Click the close icon in the header to go back to the top level web served menu.

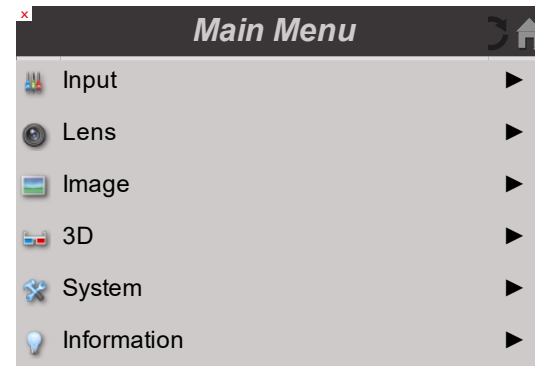

Satellite Head Touchscreen Display: Top Level Menu

Notes

See Control connections on page 1 for guidance on connecting to the projector via Ethernet.

See Introduction to the OSD on page 84 for guidance on the available controls for this system. See Introduction to the Satellite Head Touchscreen on page 108. See Introduction to the MLS 10000 Touchscreen on page 134. See Introduction to the SCM Touchscreen on page 1.

The IP address for the system can be changed on the SCM. See Network on page 146.

A SCM component menu provides access to the controls on the SCM touchscreen.

Refer to the operating guide for the SCM for guidance on using the menus. Click the close icon in the header to go back to the top level web served menu.

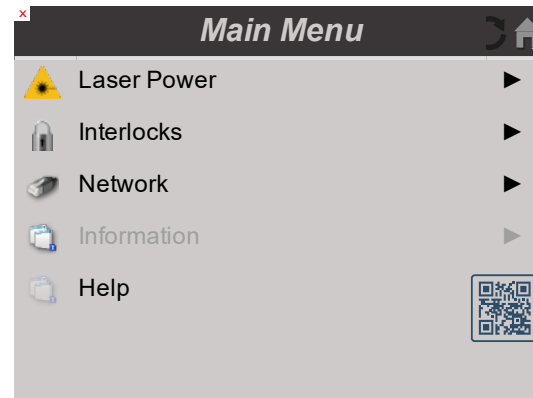

SCM Touchscreen Display: Top Level Menu

Notes

Appendix I: Glossary of terms**Notes****1****1080p**

An HDTV resolution which corresponds to 1920 x 1080 pixels (a widescreen aspect ratio of 16:9).

3**3D active glasses**

Wireless battery-powered glasses with LCD shutters. Synchronization information is communicated to the glasses by means of an infrared (IR) or radio frequency (RF) emitter which is connected to the Sync Out terminal on the projector. IR or RF pulses are transmitted by the emitter to signal when the left eye and right eye images are being displayed. The glasses incorporate a sensor which detects the emitter's signal and synchronizes the left and right eye shutters with the projected image.

3D passive glasses

Passive glasses do not require a power source to work. Light with left-hand polarization can pass through the left lens and light with right hand polarization can pass through the right-hand lens. These glasses are used in conjunction with another device which polarizes the image, such as a ZScreen.

4**4K-UHD**

The 4K-UHD resolution of 3840 × 2160 is the dominant 4K resolution used in the consumer media and display industries. This resolution has an aspect ratio of 16 :9, with 8,294,400 total pixels.

A**Adjust lines**

A pattern applied to the image where its edge is to be blended with another image. Adjust lines are used to position the projectors in the array during the edge blend process.

Anamorphic lens

A special lens which, when used with the TheaterScope aspect ratio, allows watching 2.35:1 content packed in a 16:9 source.

Aperture

The opening of the lens that determines the angle through which light travels to come into focus.

Aspect ratio

The proportional relationship between the width and the height of the projected image. It is represented by two numbers separated by a colon, indicating the ratio of image width and height respectively: for example, 16:9 or 2.35:1. Not to be confused with resolution.

B**Blanking (projection)**

The ability to intentionally turn off, that is, set to black, areas around the edges of the projected image. It is sometimes referred to as “curtains” since it can be used to blank an area of image that literally falls on the curtains at the side of the screen in a movie theater. Usually no image resizing or geometric correction takes place and the “blanked” part of the image is lost. Not to be confused with horizontal and vertical blanking (video signal).

Blanking (video signal)

The section of the video signal where there is no active video data. Not to be confused with blanking (projection).

Blend region

The area of the image that is to overlap with another image in an edge blend setup. Sometimes called overlapping region.

Brightness (electronic control)

A control which adds a fixed intensity value to every pixel in the display, moving the entire range of displayed intensities up or down, and is used to set the black point in the image (see Contrast). In Component Video signals, brightness is the same as luminance.

Brightness (optical)

Describes how ‘bright’ an image that is projected onto a screen appears to an observer.

C**C**

Also known as ‘Chrominance’, this is the component, or pair of components, of a Component Video signal which describes color difference information.

Chrominance

Also known as ‘C’, this is the component, or pair of components, of a Component Video signal which describes color difference information.

Color difference

In Component Video signals, the difference between specified colors and the luminance component. Color difference is zero for monochrome images.

Color gamut

The spectrum of color available to be displayed.

Color temperature

The position along the black body curve on the chromaticity diagram, normally quoted in Kelvin. It takes into account the preset values for color balance in the service set-up to take up the variations in the prism. The projector allows you to adjust this temperature (i.e. adjust the picture color temperature).

Notes

Component video

A three-wire or four-wire video interface that carries the signal split into its basic RGB components or luminance (brightness) and two-color difference signals (YUV) and synchronization signals.

Contrast (electronic control)

The adjustment of the white point of the image without affecting the black point. This increases the intensity range of the displayed image.

Contrast (optical)

The intensity difference between the darkest and lightest areas of the screen.

Cr, Cb

Color difference signals used with 'Y' for digital Component Video inputs. They provide information about the signal color. Not to be confused with Pr, Pb.

Crop

Remove part of the projected image. Alternatively, fit an image into a frame with a different aspect ratio by removing part of the image. The image is resized so that either its length or its width equals the length or width of the frame, while the other dimension has moved outside the frame; the excess area is then cut out.

D**Dark time**

The time inserted between frames when using 3D active glasses, to avoid ghosting caused by switching time between left and right eye.

DDC (Display Data Channel)

A communications link between the source and projector. DDC is used on the HDMI, DVI and VGA inputs. The link is used by the source to read the EDID stored in the projector.

Deinterlacing

The process of converting interlaced video signals into progressive ones.

DHCP (Dynamic Host Configuration Protocol)

A network protocol that is used to configure network devices so that they can communicate on an IP network, for example by allocating an IP address.

DMD™ (Digital Micromirror Device™)

The optical tool that transforms the electronic signal from the input source into an optical image projected on the screen. The DMD™ of a projector has a fixed resolution, which affects the aspect ratio of the projected image. A Digital Micromirror Device™ (DMD™) consists of moving microscopic mirrors. Each mirror, which acts as a pixel, is suspended between two posts by a thin torsion hinge. It can be tilted to produce either a bright or dark pixel.

Notes

E

Edge blend

A method of creating a combined image by blending the adjoining edges of two or more individual images.

Edge tear

An artifact observed in interlaced video where the screen appears to be split horizontally. Edge tears appear when the video feed is out of sync with the refresh rate of the display device.

EDID (Extended Display Identification Data)

Information stored in the projector that can be read by the source. EDID is used on the HDMI, DVI and VGA inputs, allowing the source to automatically configure to the optimum display settings.

EDTV (Enhanced Definition Television)

A progressive digital television system with a lower resolution than HDTV.

F

Field

In interlaced video, a part of the image frame that is scanned separately. A field is a collection of either all the odd lines or all the even lines within the frame.

Frame

One of the many still images displayed in a sequence to create a moving picture. A frame is made of horizontal lines of pixels. For example, a 1920x1080 frame consists of 1080 lines, each containing 1920 pixels. In analog video frames are scanned one at a time (progressive scanning) or split into fields for each field to be scanned separately (interlaced video).

Frame rate

The number of frames shown per second (fps). In TV and video, a frame rate is the rate at which the display device scans the screen to “draw” the frame.

Frame rate multiplication

To stop low frame rate 3D images from flickering, frame rate multiplication can be used, which increases the displayed frame rate by two or three times

G

Gamma

A nonlinear operation used to code and decode luminance. It originates from the Cathode Ray Tube technology used in legacy television sets.

Ghosting

An artifact in 3D image viewing. Ghosting occurs when an image intended for one eye is partially seen by the other eye. Ghosting can be removed by optimizing the dark time and sync delay.

Notes

H

HDCP (High-bandwidth Digital Content Protection)

An encryption scheme used to protect video content.

HDTV (High Definition Television)

A television system with a higher resolution than SDTV and EDTV. It can be transmitted in various formats, notably 1080p and 720p.

Hertz (Hz)

Cycles per second.

Horizontal Scan Rate

The rate at which the lines of the incoming signal are refreshed. The rate is set by the horizontal synchronization from the source and measured in Hertz.

Hs + Vs

Horizontal and vertical synchronization.

Hue

The graduation (red/green balance) of color (applicable to NTSC).

I

Interlacing

A method of updating the image. The screen is divided in two fields, one containing every odd horizontal line, the other one containing the even lines. The fields are then alternately updated. In analog TV interlacing was commonly used as a way of doubling the refresh rate without consuming extra bandwidth.

Interleaving

The alternation between left and right eye images when displaying 3D.

L

LED (Light Emitting Diode)

An electronic component that emits light.

Letterboxing

Black margins at the top and bottom of the image. Letterboxing appears when a wider image is packed into a narrower frame without changing the original aspect ratio.

Notes

Lumen

A photometric unit of radiant power. For projectors, it is normally used to specify the total amount of emitted visible light.

Luminance

Also known as 'Y', this is the part of a Component Video signal which affects the brightness, i.e. the black and white part.

N

Noise

Electrical interference displayed on the screen.

NTSC (National Television Standards Committee)

The United States standard for television - 525 lines transmitted at 60 interlaced fields per second

O

OSD (on-screen display)

The projector menus allowing you to adjust various settings.

Overlapping region

The area of the image that is to overlap with another image in an edge blend setup. Sometimes called overlapping region.

P

PAL (Phase Alternate Line)

The television system used in the UK, Australia and other countries - 625 lines transmitted at 50 interlaced fields per second.

Pillarboxing

Black margins at the left and right of the image. Pillarboxing appears when a narrower image is packed into a wider frame without changing the aspect ratio.

Pixel

Short for Picture Element. The most basic unit of an image. Pixels are arranged in lines and columns. Each pixel corresponds to a micromirror within the DMD™; resolutions reflect the number of pixels per line by the number of lines. For example, a 1080p projector contains 1080 lines, each consisting of 1920 pixels.

Pond of mirrors

Area around the periphery of the DMD™ containing inactive mirrors. The pond of mirrors may cause artifacts, for example during the edge blending process.

Notes

Pr, Pb

Color difference signals used with 'Y' for analog Component Video inputs. They provide information about the signal color. Not to be confused with Cr, Cb.

Primary colors

Three colors any two of which cannot be mixed to produce the third. In additive color television systems the primary colors are red, green and blue.

Progressive scanning

A method of updating the image in which the lines of each frame are drawn in a sequence, without interlacing.

Pulldown

The process of converting a 24 fps film footage to a video frame rate (25 fps for PAL/SECAM, 30 fps for NTSC) by adding extra frames. DP projectors automatically carry out reverse pulldown whenever possible.

R**Resolution**

The number of pixels in an image, usually represented by the number of pixels per line and the number of lines (for example, 1920 x 1200).

RGB (Red, Green and Blue)

An uncompressed Component Video standard.

S**Saturation**

The amount of color in an image.

Scope

An aspect ratio of 2.35:1.

SDTV (Standard Definition Television)

An interlaced television system with a lower resolution than HDTV. For PAL and SECAM signals, the resolution is 576i; for NTSC it is 480i.

SECAM (Sequential Color with Memory)

The television system used in France, Russia and some other countries - 625 lines transmitted at 50 interlaced fields per second.

Smooth picture

A feature that can display a higher resolution source than the native resolution of the projector without losing any pixel data.

SX+

A display resolution of 1400 x 1050 pixels with a 4:3 screen aspect ratio. (Shortened from SXGA+, stands for Super Extended Graphics Array Plus.)

Notes

Synchronization

A timing signal used to coordinate an action.

T

Test pattern

A still image specially prepared for testing a projection system. It may contain various combinations of colors, lines and geometric shapes.

TheaterScope

An aspect ratio used in conjunction with a special anamorphic lens to display 2.35:1 images packed into a 16:9 frame.

Throw distance

The distance between the screen and the projector.

Throw ratio

The ratio of the throw distance to the screen width.

TRC (Throw ratio correction)

A special number used in calculating throw distances and throw ratios when the image does not fill the width of the DMD™. TRC is the ratio of the DMD™ aspect ratio to the image source aspect ratio: $TRC = \text{DMD}^{\text{TM}} \text{ aspect ratio} / \text{Source aspect ratio}$ TRC is only used in calculations if it is greater than 1.

U

UXGA

A display resolution of 1600 x 1200 pixels with a 4:3 screen aspect ratio. (Stands for Ultra Extended Graphics Array.)

V

Vertical Scan Rate

The rate at which the frames of the incoming signal are refreshed. The rate is set by the vertical synchronization from the source and measured in Hertz.

Vignetting

Optical cropping of the image caused by the components in the projection lens. This can happen if too much offset is applied when positioning the image using the lens mount.

Vista

An aspect ratio of 1.66:1.

Notes

W

WUXGA

A display resolution of 1920 x 1200 pixels with a 16:10 screen aspect ratio. (Stands for Widescreen Ultra Extended Graphics Array.)

Y

Y

This is the luminance input (brightness) from a Component Video signal.

YUV

Color difference signals used with 'Y' for analog Component Video inputs. They provide information about the signal color. Not to be confused with Cr, Cb.

Z

ZScreen

A special kind of light modulator which polarizes the projected image for 3D viewing. It normally requires that images are projected onto a silver screen. The ZScreen is placed between the projector lens and screen. It changes the polarization of the projected light and switches between left- and right-handed circularly polarized light at the field rate.

Notes

DIGITAL PROJECTION

A brand of  DELTA

Contact Information:

Europe

Digital Projection Limited
Unit 3 Aniseed Park, Oldham
Broadway Business Park,
Oldham, England, OL9 9XA
Registered in England No.
03287264
Registered Office: As Above
Tel: (+44) 161 947 3300
enquiries@digitalprojection.co.uk
service@digitalprojection.co.uk
www.digitalprojection.co.uk

North America

Digital Projection Inc.
55 Chastain Road, Suite 115,
Kennesaw, GA 30144, USA
Tel: (+1) 770 420 1350
Fax: (+1) 770 420 1360
contact@digitalprojection.com
www.digitalprojection.com

China

Digital Projection China
中国北京市朝阳区芍药居北
里101号世奥国际中心A座2301
室(100029)
Rm A2301, ShaoYaoJu 101 North
Lane, Shi Ao International Center,
Chaoyang District, Beijing 100029,
PR CHINA
Tel: (+86) 10 84888566
Fax: (+86) 10 84888566-805
techsupport@dp-china.com.cn
www.dp-china.com.cn

Japan

Digital Projection Japan
〒105-0012 東京都港区芝大門
2-1-14
2-1-14 Shibadaimon, Minato-ku,
Tokyo, Japan 105-0012
japan@digitalprojection.co.uk
www.digitalprojection.com/jp

Taiwan

Digital Projection Taiwan
186 Ruey Kuang Rd, Neihu
District, Taipei, 114 Taiwan
Tel: +886-8797-2088 x8854
Taiwan@digitalprojection.co.uk

Korea

Digital Projection Korea
1511, Byucksan Digital Valley 6-
cha, Gasan-dong, Geumcheon-
gu, Seoul, Korea
Tel: (+82) 2 515 5303 #1417
Korea@digitalprojection.co.uk

India

Digital Projection India
Plot-43, Sector-35, HSIIDC,
Gurgaon Haryana -122001
Tel: +91-124-4874900#4275
india@digitalprojection.co.uk