

DIGITAL **PROJECTION**

A brand of  **DELTA**

TITAN Luma 35000 4K+ & 37000 WU

High Brightness Digital Video Projector

INSTALLATION & QUICK START GUIDE

CONNECTION GUIDE

OPERATING GUIDE

REFERENCE GUIDE



About This Document

Follow the instructions in this manual carefully to ensure safe and long-lasting use of the projector.

Symbols used in this manual

Many pages in this document have a dedicated area for notes. The information in that area is accompanied by the following symbols:



WARNING: this symbol indicates that there is a danger of physical injury to yourself and/or damage to the equipment unless the instructions are closely followed.



ELECTRICAL WARNING: this symbol indicates that there is a danger of electrical shock unless the instructions are closely followed.



LASER WARNING: this symbol indicates that there is a potential hazard of eye exposure to laser radiation unless the instructions are closely followed.



NOTE: this symbol indicates that there is some important information that you should read.

Product revision

Because we at Digital Projection continually strive to improve our products, we may change specifications and designs, and add new features without prior notice.

Updates may be available online - visit the Digital Projection website for all latest documents.

Legal notice

Trademarks and trade names mentioned in this document remain the property of their respective owners. Digital Projection disclaims any proprietary interest in trademarks and trade names other than its own.

Copyright © 2025 Digital Projection Ltd. All rights reserved.

Notes

Laser information



Caution - use of controls or adjustments or performance of procedures other than those specified herein may result in hazardous radiation exposure.

Optical radiation

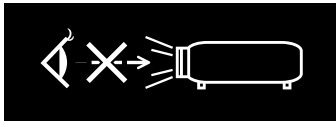

Caution - possibly hazardous optical radiation emitted from this product. Do not stare at operating light source. May be harmful to eyes. This projector is tested according to IEC/EN62471-5:2015 (Photobiological safety of lamps and lamp systems – Part 5: Image projectors standard) and is Risk Group 3 (high risk).

Notes

Light Hazard Warning

The hazard distance is the distance measured from the projection lens at which the intensity or energy per unit of surface is lower than the applicable exposure limit on the cornea or skin ❶.

The hazard zone is the area from the projection lens up to the hazard distance that encompasses where the projected beam is considered hazardous ❷.

If the person is within the hazard distance, the beam is considered unsafe for exposure.

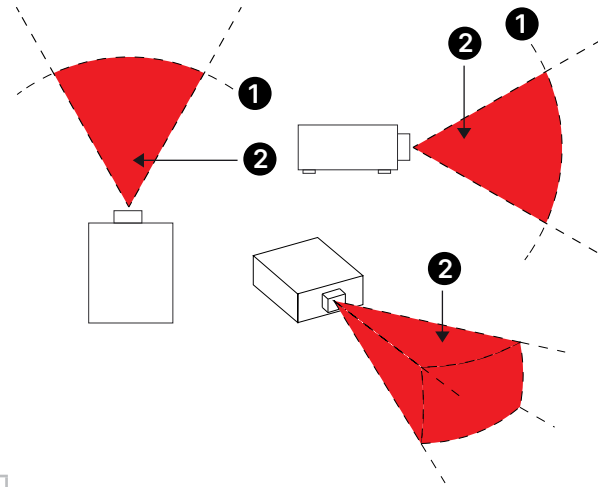

Hazard Distance

Light Hazard Distances

LENS	HAZARD DISTANCE	
	TITAN Luma 35000 4K+	TITAN Luma 37000 WU
0.37 : 1	0m	0m
0.65 - 0.85: 1	0m	0m
0.67 : 1	N/A	0m
0.8 - 1.16 : 1	1.6m	1.8m
1.12 : 1	N/A	2m
1.16 - 1.49:1	1.8m	2.1m
1.39 - 1.87:1	2.1m	2.4m
1.87 - 2.56:1	2.6m	2.8m
2.56 - 4.16:1	5.0m	5.3m
4.16 - 6.96:1	7.3m	7.8m
6.92 - 10.36:1	8m	8.3m

Notes



No direct exposure to the beam is permitted, RG3 IEC 62471-5:2015.



Operators should control access to the beam within the hazard distance or install the projector at sufficient height to prevent exposures of spectators' eyes within the hazard distance.

Restriction Zone

A restriction zone should be in place around the hazard zone to prevent any person from entering the hazard zone with any part of their body:

- Horizontal clearance **1**. This should be no less than 2.5m around the hazard zone **2**.
- Vertical clearance **3**. This should be no less than 3m between the hazard zone **2** and the floor when the projector is installed overhead.

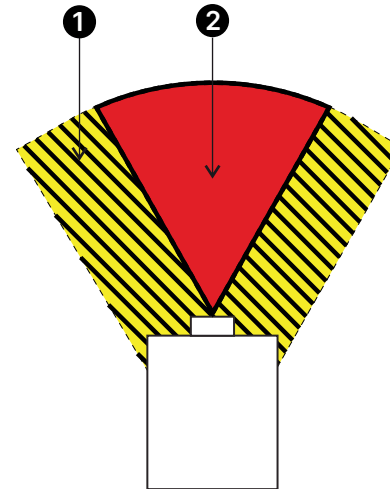

Hazard Zones - Horizontal Clearance (Top View)

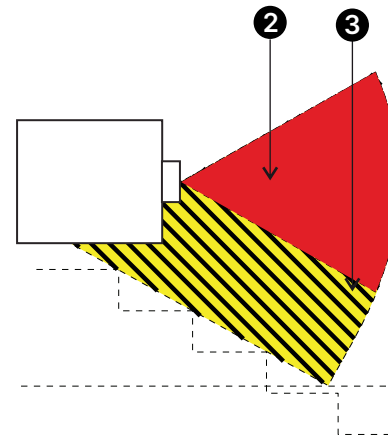

Hazard Zones - Vertical Clearance (Side View)

Notes

Introduction

This manual describes the TITAN Luma 35000 4K+ / 37000 WU.

Congratulations on your purchase of this Digital Projection product. Your projector has the following key features:

- 4K+/WUXGA projector.
- Support for Frame Sequential and Dual Pipe 3D formats.
- HDBaseT® for transmission of uncompressed High Definition Video up to 100m from the source.
- 12G-SDI with loop-through.
- Edge Blend with black level correction.
- Red laser assist for enhanced color fidelity.
- Blanking control for custom input window sizing.
- Cornerstone, Vertical & Horizontal Keystone, Pincushion & Barrel, and Image Rotation.
- Control via LAN and RS232.
- Motorised lens mount.
- Separate control of screen and source aspect ratio.
- Non-linear warp for irregular projection surfaces.
- Constant brightness mode maintains light output at selected levels.

A serial number is located on the side of the projector. Please record it here for future reference:

Notes

CONTENTS

ABOUT THIS DOCUMENT	2	CHANGING THE LENS	26
Symbols used in this manual	2	Inserting a new lens	26
Product revision	2	Removing the lens.....	26
Legal notice	2	Fitting a lens stabilizing bracket	27
LASER INFORMATION	3	OPERATING THE PROJECTOR	30
OPTICAL RADIATION	3	Switching the projector on:	30
LIGHT HAZARD WARNING	4	Switching the projector off.....	30
Light Hazard Distances	4	Selecting an input signal	30
Restriction Zone.....	5	Selecting a test pattern.....	30
INTRODUCTION	6	Adjusting the lens	31
		Lens menu.....	31
		Remote control.....	31
INSTALLATION & QUICK START GUIDE	11	Adjusting the image	31
		Orientation.....	31
WHAT'S IN THE BOX?	12	Geometry	31
CONNECTING THE POWER SUPPLY	13	Picture	31
PROJECTOR OVERVIEW	14	CONNECTION GUIDE	33
CONTROL PANEL	15		
REMOTE CONTROL	17	SIGNAL INPUTS	34
Infrared reception	20	Digital inputs and outputs.....	34
POSITIONING THE SCREEN AND PROJECTOR	21	EDID on the DisplayPort, HDMI, and HDBaseT inputs	35
Roll and pitch	22	Using DisplayPort/ HDMI/ HDBaseT switchers with the projector	35
Stacking and rigging	23	3D CONNECTIONS	36
Pin and cup stacking	23	Frame sequential 1080p 3D up to 120Hz and WUXGA 3D at 100Hz.	36
Using the eye bolts	24	Dual Pipe 1080p and WUXGA 3D sources at up to 100 and 120Hz	36
Point-to point connections	24	3D Sync.....	37
Threaded suspension cables.....	25		

CONTENTS (continued)

CONTROL CONNECTIONS	38	Geometry menu	56
LAN connection examples	39	Aspect ratio	56
RS232 connection example	40	Digital zoom	58
OPERATING GUIDE	41	Overscan	58
USING THE MENUS	42	Blanking	59
Opening the Menu	42	Warping Mode	59
Opening a submenu	42	Keystone	60
Exiting menus and closing the OSD	43	4 corners	62
Inside a menu	43	Pincushion / Barrel	63
Accessing sub menus	44	Wall Corner	64
Executing commands	44	Free Grid	64
Editing projector settings	45	Custom warp	65
Using a slider to set a value	45	Edge blend menu	66
Editing numeric values	46	Blend start	67
USING THE PROJECTOR	47	Black level uplift	68
Main menu	47	Uniformity	69
Input menu	47	3D menu	70
Input	47	3D types	71
Lens menu	48	Some 3D settings explained	72
Lens control	48	Laser menu	74
Lens memory	49	Setup menu	75
Image menu	50	ColorMax	77
Color menu	52	Power on / off	78
Color space	52	Clock adjust	79
Color mode	53	PIC mute setting	79
		OSD settings	80
		Memory	80
		EDID Mode	80

CONTENTS (continued)

Network menu	81	POSITIONING THE IMAGE	108
Network setup.....	81	ASPECT RATIOS EXPLAINED	110
Art-net setup	82	Aspect ratios examples	110
Art-net Channel setting.....	82	Source: 4:3	110
Art-Net Channel Status.....	82	Source: 16:9	111
Information menu	83	Source: 16:10 (native)	111
Software Version	83	Aspect ratio example: TheatreScope	112
Signal format.....	83	APPENDIX A: SUPPORTED SIGNAL INPUT MODES	113
System status	84	2D formats.....	113
Thermal status	84	12G-SDI (SDI Format).....	116
Factory reset	84	3D formats.....	118
SERVED WEB PAGES	85	APPENDIX B: WIRING DETAILS	120
REFERENCE GUIDE	99	Signal inputs and outputs.....	120
CHOOSING A LENS	100	HDMI 1 and 2.....	120
Basic calculation	101	DisplayPort	120
Basic calculation example.....	102	12G-SDI in, 12G-SDI out	121
Full lens calculation	103	HDBaseT input	121
Introducing TRC	103	Control connections.....	122
Calculating TRC	104	LAN.....	122
Calculating the throw ratio with TRC	104	RS232.....	122
Full lens calculation example	105	Wired Remote Control Input.....	122
SCREEN REQUIREMENTS	106	APPENDIX C: MEMORY SCHEME AND MEMORY ITEMS	123
Fitting the image to the display	106	APPENDIX D: GLOSSARY OF TERMS	127
WUXGA images displayed full width	106		
WUXGA images displayed with a height of 1200 pixels	106		
WUXGA images displayed full height	107		
Diagonal screen sizes	107		

This page is intentionally left blank.

DIGITAL **PROJECTION**

A brand of  **DELTA**

TITAN Luma 35000 4K+ & 37000 WU

High Brightness Digital Video Projector

INSTALLATION & QUICK START GUIDE



What's In The Box?

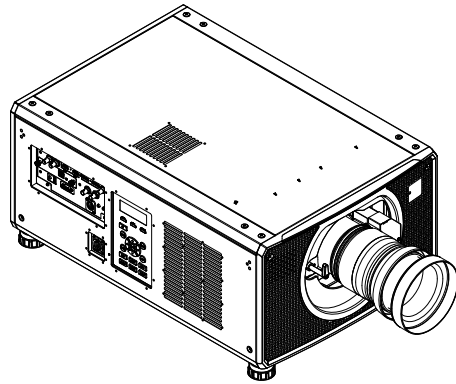

Projector

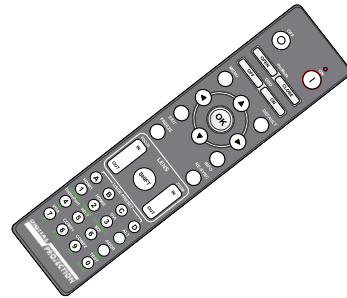

Remote Control

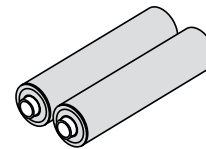

Batteries

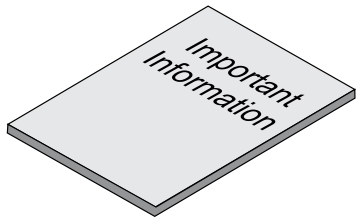

Important Information Book

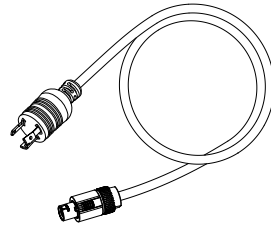

Power Cable, USA only

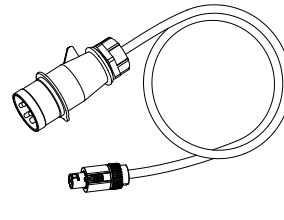

Power Cable, EMEA/ China

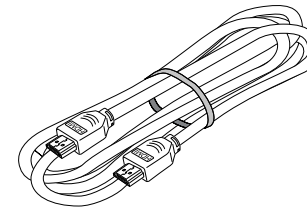

HDMI Cable

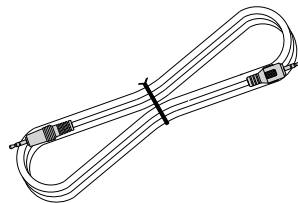

Remote Control Cable





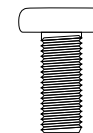

Lens Stabilizing Bracket



**M4*10L HEXI Screw *2
For lens stabilization bracket**

Notes

-  *Make sure your box contains everything listed. If any pieces are missing, contact your dealer..*
-  *Only one remote is supplied with the projector.*
-  *Save and store the original box and packing materials, in case you ever need to ship your projector.*
-  *The projector is shipped without a lens.*
-  *Only the appropriate cable for destination territory is supplied with the projector*

Connecting The Power Supply

Rest of the World:

1. Firmly push the mains connector into the **socket 1**.

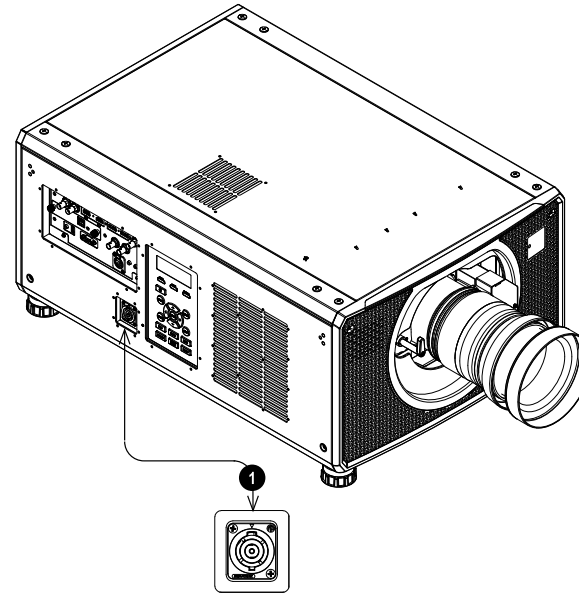

Notes



Use only the power cable provided.



Ensure that the power outlet includes a ground connection as this equipment **MUST** be earthed.



Handle the power cable carefully and avoid sharp bends. Do not use a damaged power cable.

Projector Overview

1. Connections panel
2. Control panel
3. Mains socket
4. Adjustable feet (x4)

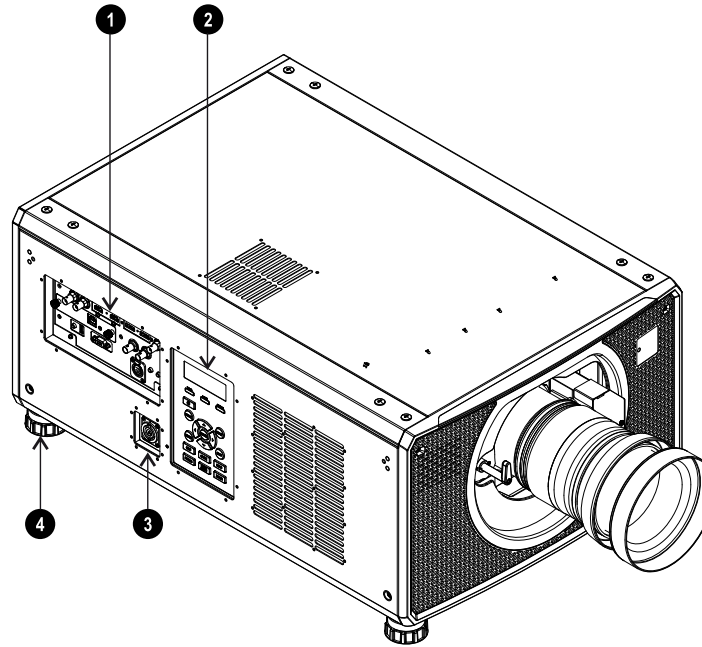

Front View

Notes

Control panel

1. TEMP INDICATOR

Off = no problem
 Flashing red = temperature error

2. LIGHT INDICATOR

Off = light is switched off
 Flashing red (cycles of single flashes) = failure to light up during power up
 Flashing red (cycles of double flashes) = unexpected light off while running
 On, green = light is switched on
 On, orange = light is switched on but run on forced eco mode when high temperature
 Flashing green (cycles of single flashes) = light source is temporary off by PIC-MUTE CLOSE.

3. STATUS INDICATOR

Off = no problem
 Flashing red (cycles of single flashes) = cover error
 Flashing red (cycles of double flashes) = TEC/color Sensor error
 Flashing red (cycles of four flashes) = fan error
 On, red = system error
 On, orange = firmware upgrade mode
 Flashing orange (cycles of double flashes) = request to re-execute the lens calibration (Center Lens) process
 Flashing green (cycles of double flashes) = lens calibration (Center Lens) is processing

4. POWER

Switches the projector on and off (STANDBY).
 Indicator:

- Off. ● The projector is switched off
- Flashing green. ⚙ The projector is warming up
- Flashing orange. ☀ The projector is cooling down
- On, red. ● Standby mode: power saving without network control capability.
- On, orange. ● Standby mode: with network control capability
- On, green. ● The projector is switched on.

5. SYNC

Re-synchronises with the current input signal.

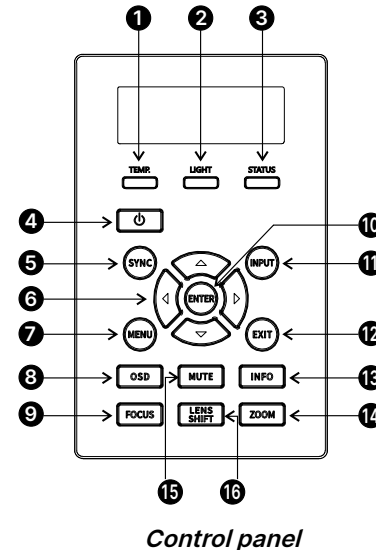

Notes

6. Arrow buttons & ENTER

Navigation buttons used to highlight menu entries in the OSD. Press ENTER to open or execute the highlighted menu entry.

7. MENU

Displays and exits the OSD.

8. OSD

On Screen Display Menu Disable/Enable.

9. FOCUS

Plus and minus buttons move the focus in and out.

10. ENTER

Use the button to select settings or confirm the changed settings.

11. INPUT

Switches to the next input source.

12. EXIT

Exits the current OSD page and enters the level above.

13. INFO

Display the current system status.

14. ZOOM

Plus and minus buttons zoom in and out.

15. MUTE

Hides the projected image.

16. LENS SHIFT

Arrow buttons move the lens in the specified direction.

Notes

Remote Control

1. **Power ON / OFF**
Turns power on and off.
2. **Pic Mute OPEN / CLOSE**
Shows and hides the projected image.
There are two PIC Mute settings:
 - Laser. When off, the laser is switched off and no image is projected
 - DMD Blanking. When off, the laser remains on and a black image is projected
3. **OSD ON / OFF**
Enable and disable screen timeout messages and control whether to show the OSD during projection.
4. **MENU**
Access the OSD. If the OSD is open, press this button to go back to the previous menu.
5. **Navigation (arrows and OK)**
Navigate through the menus with the arrows, confirm your choice with **OK**.
In lens adjustment modes, the arrows are used to move, zoom or focus the lens.
See 11 below. In lens adjustment modes, or when the OSD is not showing, the OK button switches between modes: **Shift Adjustment** and **Zoom / Focus Adjustment**.
6. **EXIT**
Go up one level in the OSD. When the top level is reached, press to close the OSD.
7. **FREEZE**
Freeze the current frame.
8. **DEFAULT**
When editing a parameter, press this button to restore the default value.
9. **INFO**
Access information about the projector.
10. **RE-SYNC**
Re-synchronise with the current input signal.

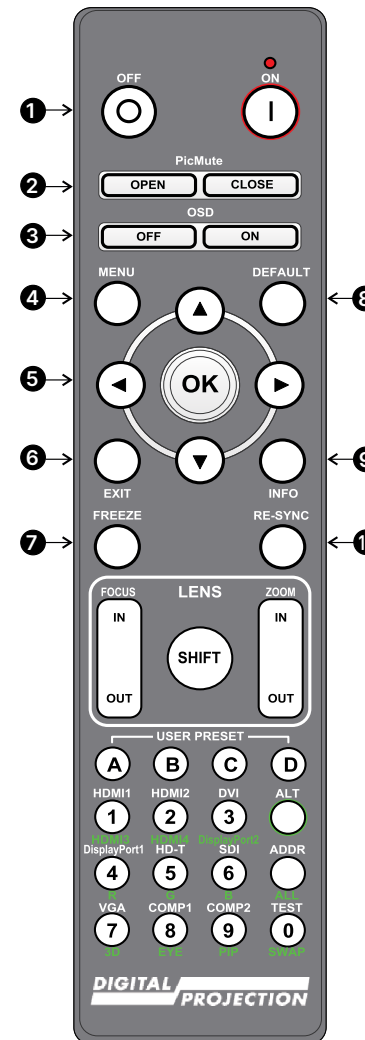

Remote Control

Notes

 The "PIC mute setting" is defined in the setup menu. See Setup menu on page 80

11. **LENS adjustment**

- **FOCUS IN / OUT:** adjust focus.
- **SHIFT:** press and hold this button, then use the Navigation arrow buttons to move the lens.
- **ZOOM IN / OUT:** adjust zoom.

12. **USER PRESET A, B, C, D**

Load user presets.

13. **ALT**

Press and hold this button to access alternative functions for all buttons with a green label.

14. **DVI / DisplayPort2 / numeric input 3**

There is no DVI input on this projector.
Use with **ALT** to select the DisplayPort 2 input.

15. **HDMI 2 / HDMI 4 / numeric input 2**

Select the HDMI 2 input.
Use with **ALT** to select the HDMI 4 input. There is no HDMI 4 input on this projector.

16. **HDMI 1 / HDMI 3 / numeric input 1**

Select the HDMI 1 input.
Use with **ALT** to select the HDMI 3 input. There is no HDMI 3 input on this projector.

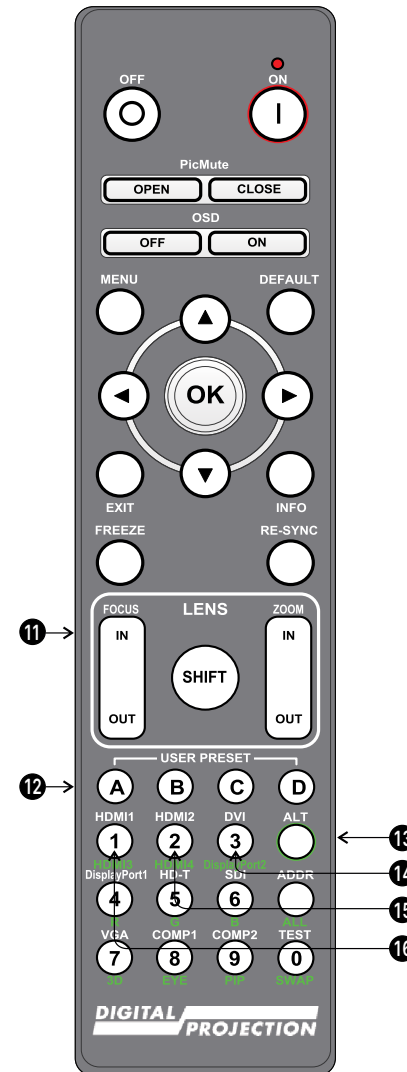

Remote Control

Notes



If focus cannot be achieved using the focus in / out feature, press Shift & 7 to adjust for far focus, or Shift & 8 to adjust for near focus.



This projector does not use the following options on the remote: DVI, VGA, HDMI 3, HDMI 4, COMP 1, COMP 2, PIP and SWAP.

17. **DISPLAYPORT 1 / R / numeric input 4**

Select DisplayPort 1 input.

18. **HD-T / G / numeric input 5**

Select the HDBaseT input.

19. **VGA / 3D / numeric input 7**

There is no VGA input on this projector.

Use with **ALT** to toggle the 3D Format setting between Off and Auto.

20. **COMP1 / EYE / numeric input 8**

There is no Component 1 input on this projector.

Use with **ALT** to switch between left and right eye 3D dominance.

21. **ADDR / ALL (with red indicator at the top)**

Assign and unassign an IR remote address.

- **To assign an IR remote address:**

1. Press and hold this button until the red indicator starts flashing.
2. Release this button and while the red indicator is still flashing, enter a two-digit address using the numeric input buttons. The indicator will flash three times quickly to confirm the change.

- **To unassign an address and return to the default address 00:**

1. Press and hold **ALT** and this button simultaneously until the red indicator flashes to confirm the change.

22. **SDI / B / numeric input 6**

Select the 12G-SDI input.

23. **TEST / SWAP / numeric input 0**

Show a test pattern. Press again to show the next test pattern: Off, White, Black, Red, Green, Blue, Checkerboard, Crosshatch, Color Bar, Aspect Ratio.

24. **COMP2 / PIP / numeric input 9**

There is no Component 2 input on this projector.



Remote Control

Notes

This projector does not use the following options on the remote: DVI, VGA, HDMI 3, HDMI 4, COMP 1, COMP 2, PIP and SWAP.

Infrared reception

The projector has infrared sensors at the front and back.

The angle of acceptance is 40°. Make sure that the remote control is within the angle of acceptance when trying to control the projector.

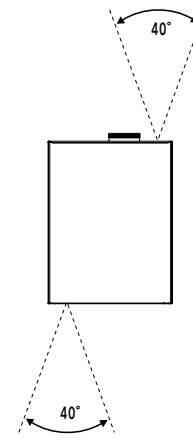

Notes

Positioning the screen and projector

1. Install the screen, ensuring that it is in the best position for viewing by your audience.
2. Mount the projector, ensuring that it is at a suitable distance from the screen for the image to fill the screen. Set the adjustable feet so that the projector is level, and perpendicular to the screen.

The drawing shows the positions of the feet for table mounting, and the fixing holes for ceiling mounting.

1. Four adjustable feet
2. Four M10 holes for ceiling mount

The screws should not penetrate more than 15 mm into the body of the projector.

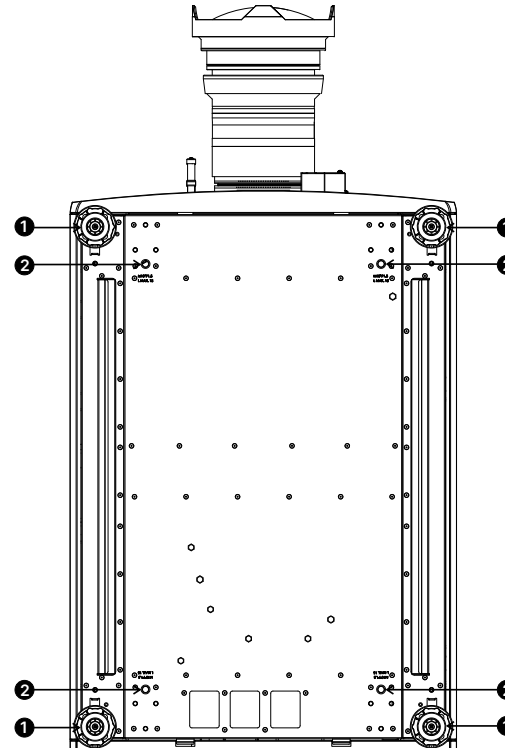

Notes



Always allow the projector to cool for 5 minutes before disconnecting the power or moving the projector.



Ensure that there is at least 50 cm (19.7 in) of space between the ventilation outlets and any wall, and 30 cm (11.8 in) on all other sides.



Do not use the threaded holes for the adjustable feet to hang or mount the projector.

Roll and pitch

The projector can be operated in numerous positions.

In portrait mode, it is recommended to position the projector with inputs facing upward, as shown in the diagram.

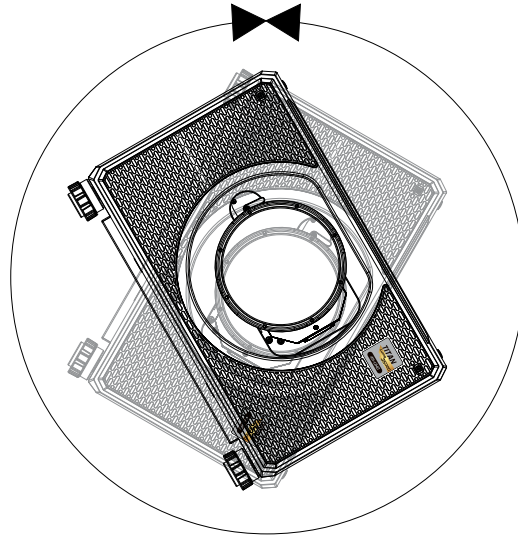

Roll

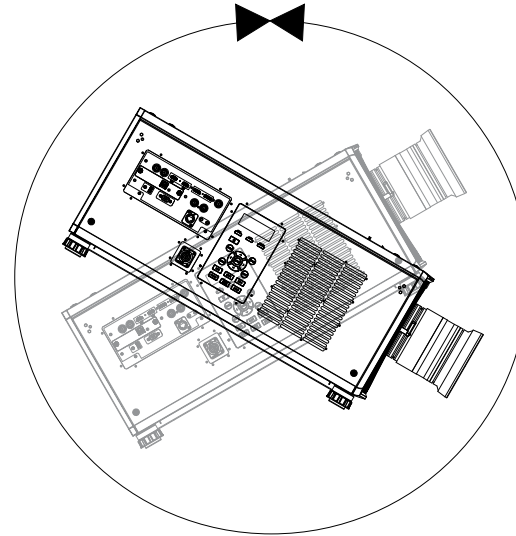

Pitch

Notes

Stacking and rigging (Optional)

The projector can be stacked using the pin and cups that are located on top and underneath the projector. The pin and cups can also be used to attach a mounting rail. The eye bolts on top of the projector can be used with suspension cables to fly the projector.

Pin and cup stacking

Install the locking pins and cups. The pins and cups can connect together and be locked into place with a locking pin.

1. Remove the screws on the top of the projector and install the locking pins. ❶
2. Install the cups with M6 screws and match the shape of adjustable feet (not interference) ❷
3. Mount the projector on top of the other projector.
Ensure that all four cups are placed over the pins on the bottom projector. ❸
4. Push the locking pins into place on each cup and pin. ❹

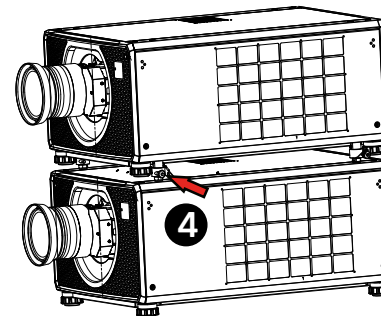
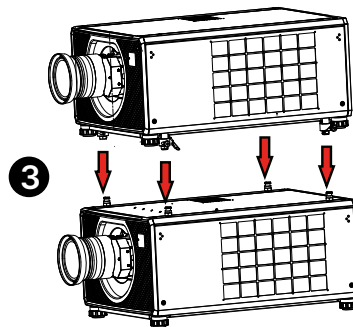
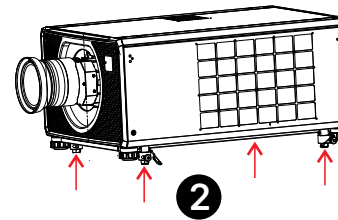
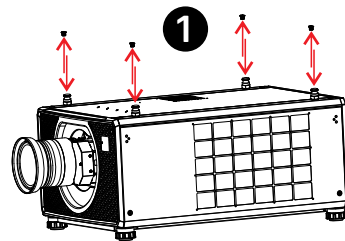

Notes



Do not use the threaded holes for the adjustable feet to hang or mount the projector.



Do not use the carry handles to hang or mount the projector.



This system should only be used to stack a maximum two projectors.

Using the eye bolts

Install eye-bolts

Remove the screws on the top of the projector and install eye-bolts to enable the flying of the projector using steel wire or chains.

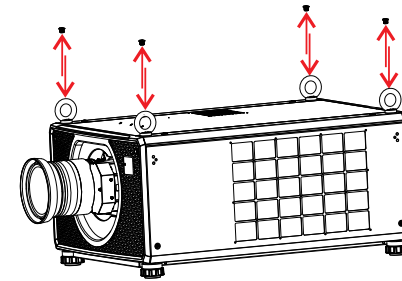

Point-to-point connections

Refer to the following guidelines when connecting one end of a suspension cable directly to an eye-bolt and the other to a suspension point..

- The suspension cables can be connected to the eye-bolts at an angle of up to 45° around the eye ring.
- The suspension cables must not be connected to the eye-bolts at any angle across the eye ring.
- The suspension cable must run vertically up from the projector..

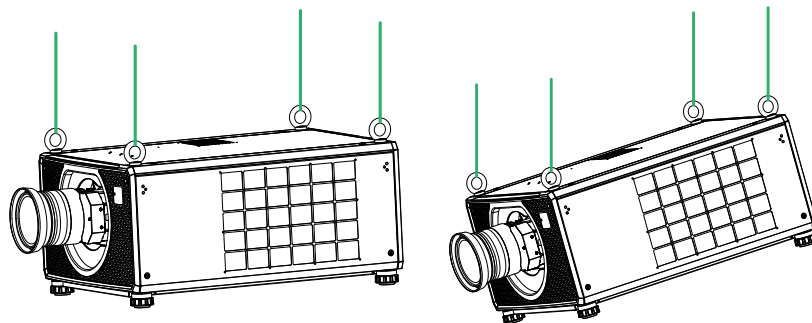
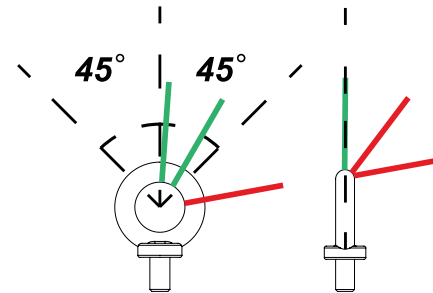

Example of a correct configurations

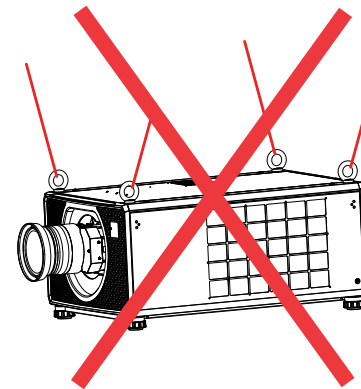

Example of an incorrect configurations

Notes



This system should only be used to fly a single projector. Do not stack projectors and fly them together.

Threaded suspension cables

Refer to the following guidelines when threading the suspension cable through the eye-bolts and connecting both ends to suspension points.

- The suspension cable can exit the eye-bolts at an angle of up to 45° around the eye ring.
- The suspension cable can exit the eye-bolts at an angle of up to 45° across the eye ring.
- The suspension cable should not be threaded through 2 or more eye-bolts

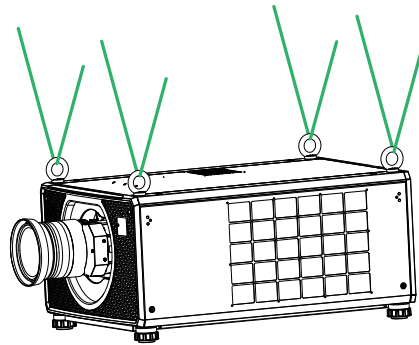
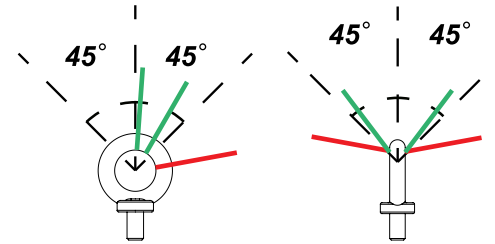

Example of a correct configurations



Example of an incorrect configurations

Notes

Changing the lens

Inserting a new lens

1. Turn the lens release lever clockwise so that it is pointing upwards, to open the lock fully. ❶
2. Remove the rear lens cap from the lens.
3. Insert the lens into the lens aperture, making sure that the plug on the zoom drive mechanism lines up with the socket on the front of the projector, then push the lens in firmly as far as it will go.
4. Turn the lens release lever anti-clockwise to the mid-position. ❷
5. The lens can now be pushed in further. Push the lens in firmly as far as it will go.
6. Turn the lens release lever fully anti-clockwise so that it is pointing downwards, to close the lock fully. ❸

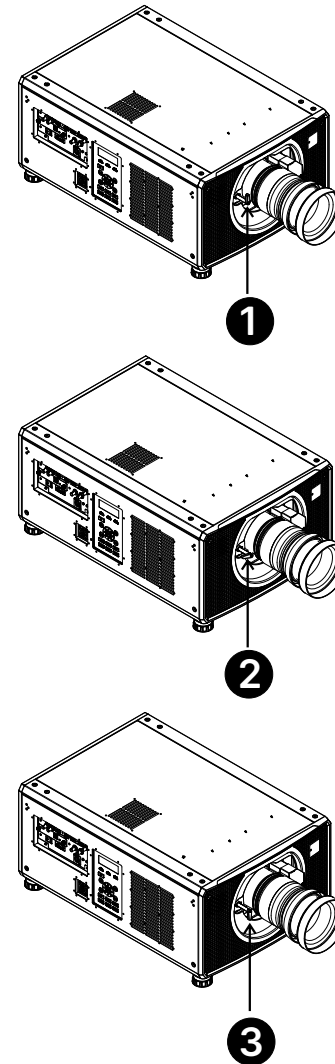

Notes



Before changing the lens, always make sure the projector is switched off and fully disconnected from its power supply.



When changing the lens, avoid using excessive force as this may damage the equipment..



Avoid touching the surface of the lens as this may result in image impairment.



The lens is shipped separately..



Take care to preserve the original lens packaging and protective caps for future use.



An adapter is available for certain third party lenses. Please see your local dealer for further information



HOTKEY 3 is used when a lens adapter is installed. Whilst in standby mode, press and hold HOTKEY 3 for five seconds to run center lens before installing the lens.

Removing the lens

To remove the lens, reverse the procedure described in Inserting a new lens above:

1. Turn the release lever up to the mid-position, then pull the lens out as far as it will go.
2. Turn the release lever clockwise so it is pointing upwards, then pull the lens out completely.

Fitting a lens stabilizing bracket

1. Remove the cover from the front of the projector.
2. Remove the lens mount and lens.

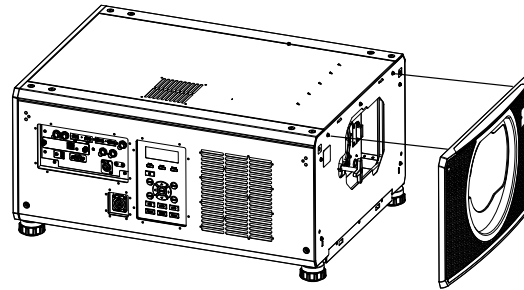

3. Remove the three M3 set screws from the lens collar.
4. Remove the two M3 screws from the fixed lens bracke.
5. Remove the lens collar from the lens.

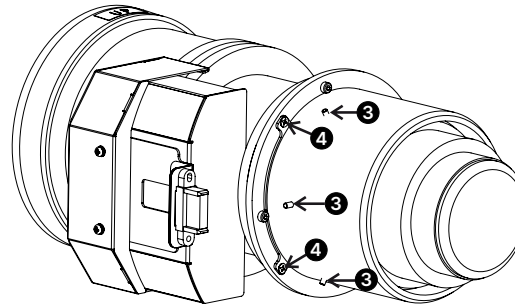

Notes



In some applications and projector orientations, it may be necessary to fit the stabilizing bracket to the lens mount..



The lens stabilizing bracket can only be fitted to models built from April 2019.

6. Remove the two M2 screws from the fixed lens bracke.
7. Remove the fixed lens bracket.

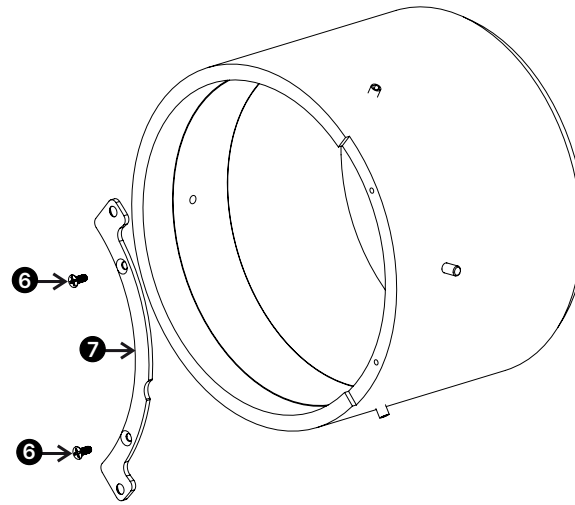

8. Place the stabilizing bracket on to the lens collar.
9. Screw in the two M2 screws to fix the stabilizing bracket to the lens collar.

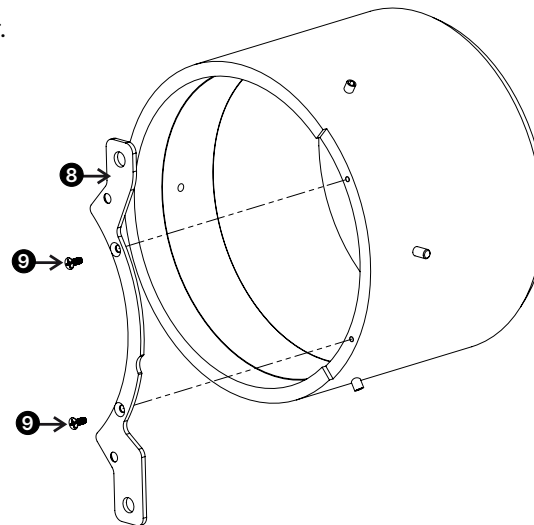

Notes

- 10. Place the lens collar on to the lens.
- 11. Screw in the two M3 screws to fix the lens collar to the lens.
- 12. Screw in the three M3 set screws to the lens collar.

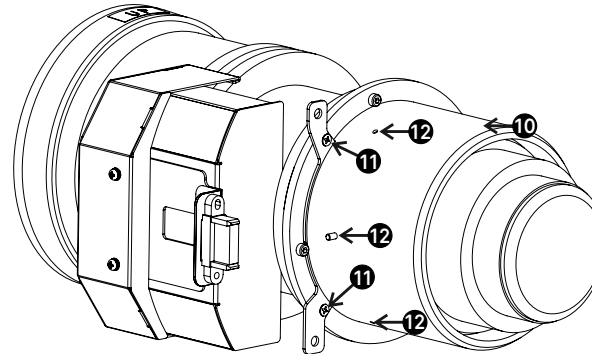

- 13. Place the lens into the projector.
- 14. Screw the two fixing screws (M4*10L HEXI screws in the accessory box) into the lens stabilizing bracket.
- 15. Push this metal part in the direction of the arrow to hold the lens in place, then used tool tighten the two screws.
- 16. Place the cover over the front of the projector.

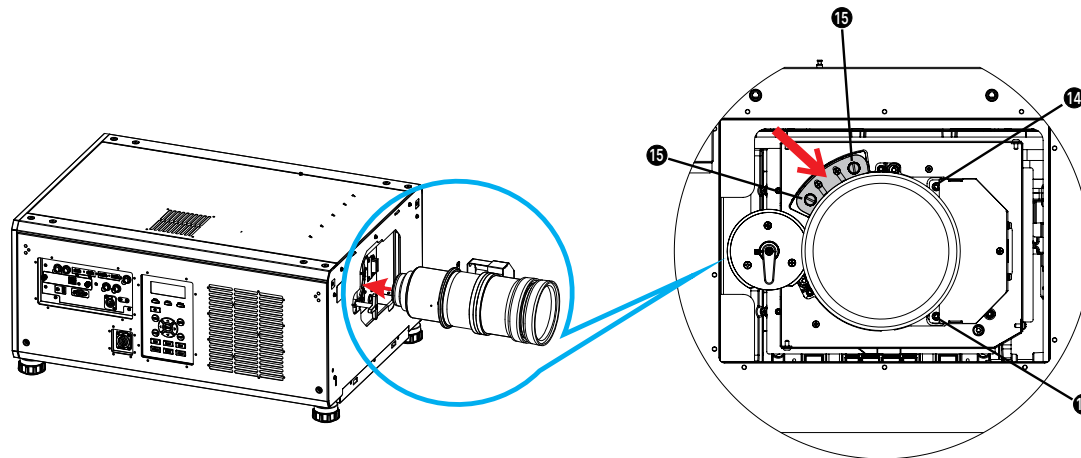

Notes

Operating the projector

Switching the projector on:

1. Connect the power cable between the mains supply and the projector. (See Connecting the power supply above.) The **POWER** indicator turns red to signal that the projector is on and in STANDBY mode.
2. Press one of the following buttons:
 - On the remote control, the **ON** button
 - On the projector control panel, the **POWER** button.

The **POWER** indicator begins flashing green as the projector powers up. When the flashing stops, the **POWER** indicator lights solid green and the Digital Projection logo appears on the screen. The projector is switched on and projecting.

Switching the projector off

1. Press **OFF** on the remote control or **POWER** on the control panel, then press again to confirm your choice. The **POWER** indicator on the control panel will start flashing blue, the projected image will turn off and the cooling fans will run for a short time until the **POWER** indicator goes steady red to indicate that the projector has entered STANDBY mode.
2. If you need to switch the projector off completely, please disconnect the power cable from the projector.

Selecting an input signal

1. Connect one or more image sources to the projector.
2. Select the input you want to display:
 - Press one of the input buttons on the remote control.
 - Alternatively, open the On-screen display (OSD) by pressing **MENU**. Highlight **Input** from the main menu, press **ENTER/OK** and then select an input signal using the **UP** and **DOWN** arrow buttons. Press **ENTER/OK** to confirm your choice.

Selecting a test pattern

To display a test pattern:

- Press **TEST** on the remote control. Change the test pattern using the **LEFT** and **RIGHT** arrow buttons. The following test patterns are available: Off, White, Black, Red, Green, Blue, Checkerboard, Crosshatch, Color Bar, Aspect Ratio
- Alternatively, open the OSD by pressing **MENU**. Highlight **Test Patterns** from the main menu, then select a test pattern using the **LEFT** and **RIGHT** arrow buttons.

After the final test pattern, the projector exits test pattern mode and returns to the main image. To view test patterns again, you need to press **TEST** again. If you wish to exit the test patterns before you reach the final one, press **TEST** or **EXIT** at any time.

Notes



See "Connecting The Power Supply" on page 13.



The self-test is running when all the LEDs on the control panel are lit.



Use only the power cable provided.



Ensure that the power outlet includes a ground connection as this equipment MUST be earthed.



Handle the power cable carefully and avoid sharp bends. Do not use a damaged power cable.



See "Using the menus" on page 42 for full details of how to use the controls and the menu system.

Adjusting the lens

The lens can be adjusted by using the lens menu or the lens buttons on the remote control.

Lens menu

The Lens menu provides access to the Lens Control setting and the Lens Center command.

Lens Control allows Zoom, Focus and Shift adjustments using the arrow buttons. The setting operates in Zoom/Focus Adjustment and Shift Adjustment mode.

Press ENTER/SELECT to switch between the two modes.

Remote control

Use the remote control to adjust zoom, focus and shift directly, without opening a menu:

- OK enters lens control, then switches between Zoom/Focus Adjustment and Shift Adjustment.
- EXIT exits lens control and opens the Lens menu.
- MENU exits lens control and returns to the main image.
- The arrow buttons adjust zoom, focus and shift as indicated on the screen. Selecting a test pattern

Adjusting the image

Orientation

This can be set from the Setup menu.

Highlight Orientation and choose from Front Tabletop, Front Ceiling, Rear Tabletop, Rear Ceiling and Auto-front.

Geometry

Settings such as Keystone, Pincushion / Barrel can be set from the Geometry menu.

Picture

Settings such as Gamma, Brightness, Contrast, Saturation, Hue and Sharpness can be set from the Image menu.

Notes



See "Remote Control" on page 17 for full details of how to adjust the lens using the remote control.

This page is intentionally left blank.

DIGITAL **PROJECTION**

A brand of  **DELTA**

TITAN Luma 35000 4K+ & 37000 WU

High Brightness Digital Video Projector

CONNECTION GUIDE



Signal inputs

Digital inputs and outputs

1. HDMI 1 / HDMI 2

HDMI 2.0 inputs supporting HDCP 2.2. Connect an HDMI cable to the connector.

2. DisplayPort

DisplayPort 1.2 input. Connect a DisplayPort cable to the connector. Supports sources up to 4K+ resolution at 60 Hz and WUXGA at 120Hz.

3. HDBaseT

Receives digital signal from HDBaseT-compliant devices. Connect an HDBaseT cable.

4. SDI IN

SDI input supporting up to 12G-SDI. Connect an SDI cable to the connector.

5. Ethernet/Art-Net

Provides LAN connectivity via an ethernet or Art-Net cable.

6. SDI OUT

SDI output supporting up to 12G-SDI. Connect an SDI cable to distribute the SDI signal to another projector.

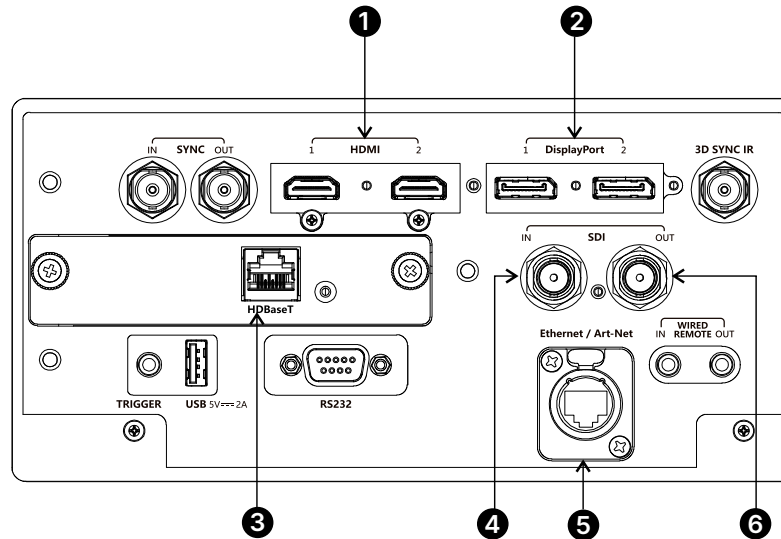

Notes



For simultaneous HDBaseT and LAN connectivity, a third-party distribution product can be utilised to combine HDBaseT video stream with LAN connection for delivery to the projector.

EDID on the DisplayPort, HDMI, and HDBaseT inputs

If you are using a computer graphics card or another source that obeys the EDID protocol, the source will automatically configure itself to suit the capability of the projector.

Otherwise refer to the documentation supplied with the source to manually set the resolution to the DMD™ resolution of the projector or the nearest suitable setting. Switch off the source, connect to the projector, then switch the source back on again.

Using DisplayPort/ HDMI/ HDBaseT switchers with the projector

When using a DisplayPort/HDMI/HDBaseT source switcher with the projector, it is important to set the switcher so that it passes the projector EDID through to the source devices.

If this is not done, the projector may not be able to lock to the source or display the source correctly as its video output timings may not be compatible with those of the projector. Sometimes this is called transparent, pass-through or clone mode. See your switcher's manual for information on how to set this mode.

1. Sources
2. Switcher
3. Projector

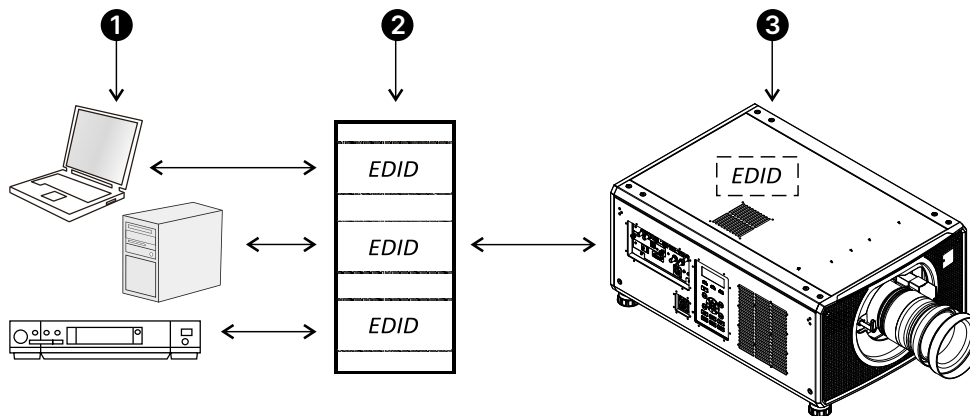

The EDIDs in the switcher should be the same as the one in the projector.

Notes

3D connections

1. Sync In / Sync Out

Sync In is the 3D sync input signal. Connect the 3D sync from your graphics card or server.

Sync Out is the 3D sync output signal. Enables 3D from multiple projectors.

2. 3D Sync IR

Sync output signal. This is affected by settings in the 3D menu such as Dark Time and 3D Sync Offset. Connect this to an IR emitter or ZScreen.

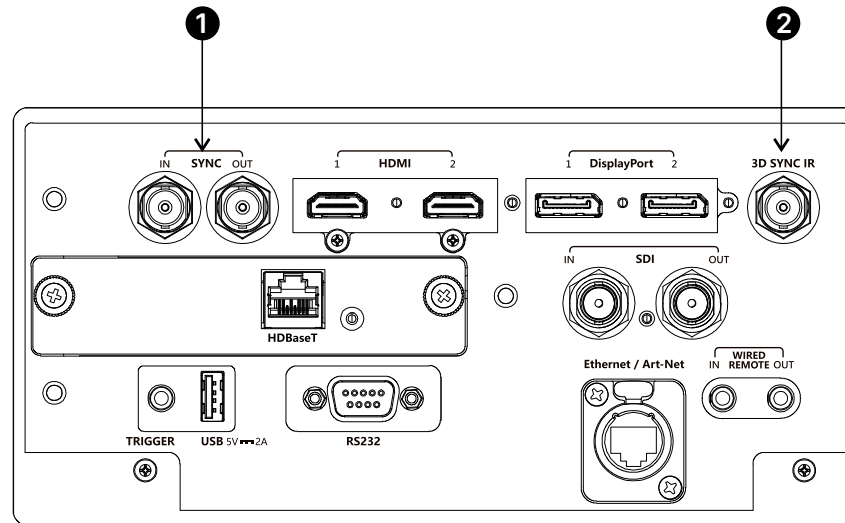

Notes

See "3D formats" on page 115 for a complete list of supported formats and frame rates.

Frame sequential 1080p 3D up to 120Hz and WUXGA 3D at 100Hz.

1. Set 3D Format in the 3D menu to Frame Sequential.

Dual Pipe 1080p and WUXGA 3D sources at up to 100 and 120Hz

1. Connect the left eye output to the HDMI 1 socket and the right eye output to the HDMI 2 socket.
2. Set 3D Format in the 3D menu to Dual-Pipe.

3D Sync

- 1. 3D Input
- 2. 3D Sync In
- 3. 3D Sync IR
- 4. IR emitter or Zscreen

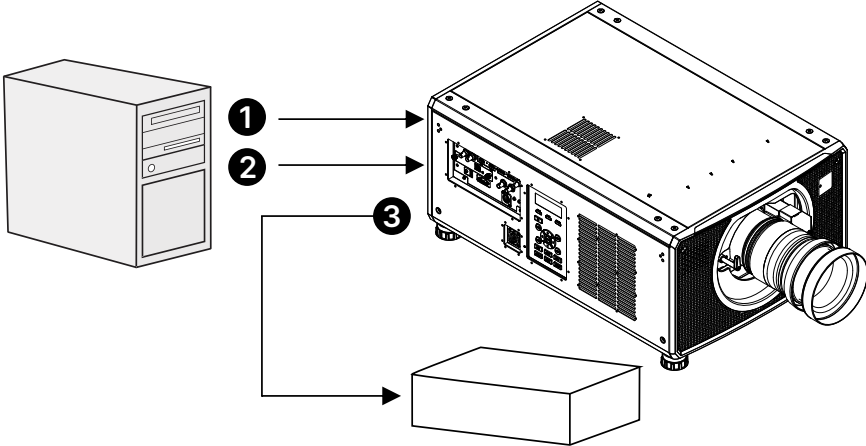

Notes

Control connections

1. Trigger

The Trigger outputs are defined in the Setup menu. Each output can be triggered by one of the following conditions:

- Screen trigger. A trigger output can be used to control an electrically operated screen. The screen will be automatically deployed when the projector starts up and retracted when the projector shuts down.
- Aspect ratio trigger. A trigger output can be used to control screen shuttering for different aspect ratios.
- RS232 trigger. A trigger output can be used to control the screen or screen shuttering on receipt of an RS232 command.

2. USB

USB 5V / 2A output. Connect a USB cable to supply power to an external device.

3. HDBaseT (Optional board)

The projector's features can be controlled via a LAN connection, using Digital Projection's Projector Controller application or a terminal-emulation program.

4. RS232

All of the projector's features can be controlled via a serial connection, using commands described in the Protocol Guide. Use a straight-through cable to connect directly to a computer.

5. Ethernet/ArtNet

• **Ethernet**

The projector's features can be controlled via a LAN connection. For example using Digital Projection's Projector Controller application, a terminal-emulation program or PJ-Link.

• **Art-Net**

Art-Net compatible RJ45 etherCON input. Connect an etherCON connector cable from an Ethernet LAN/WLAN network to receive DMX-512 data over an IP-based network.

6. Wired Remote

The remote control can be connected using a standard 3.5 mm mini jack cable (tip-ring-sleeve, or TRS).

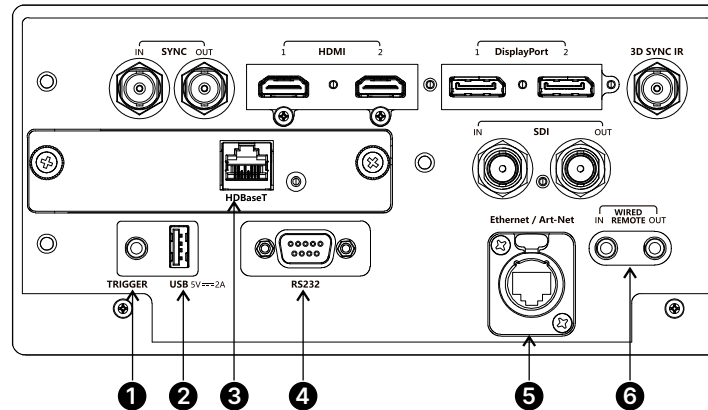

Notes



For a list of all commands used to control the projector via LAN, see the Protocol Guide (available separately).



Only one remote connection (RS232 or LAN) should be used at any one time.



With a LAN connection the projector can serve a web page offering status and projector controls.





Projector Controller is available for download, free of charge, from the Digital Projection website.

LAN connection examples

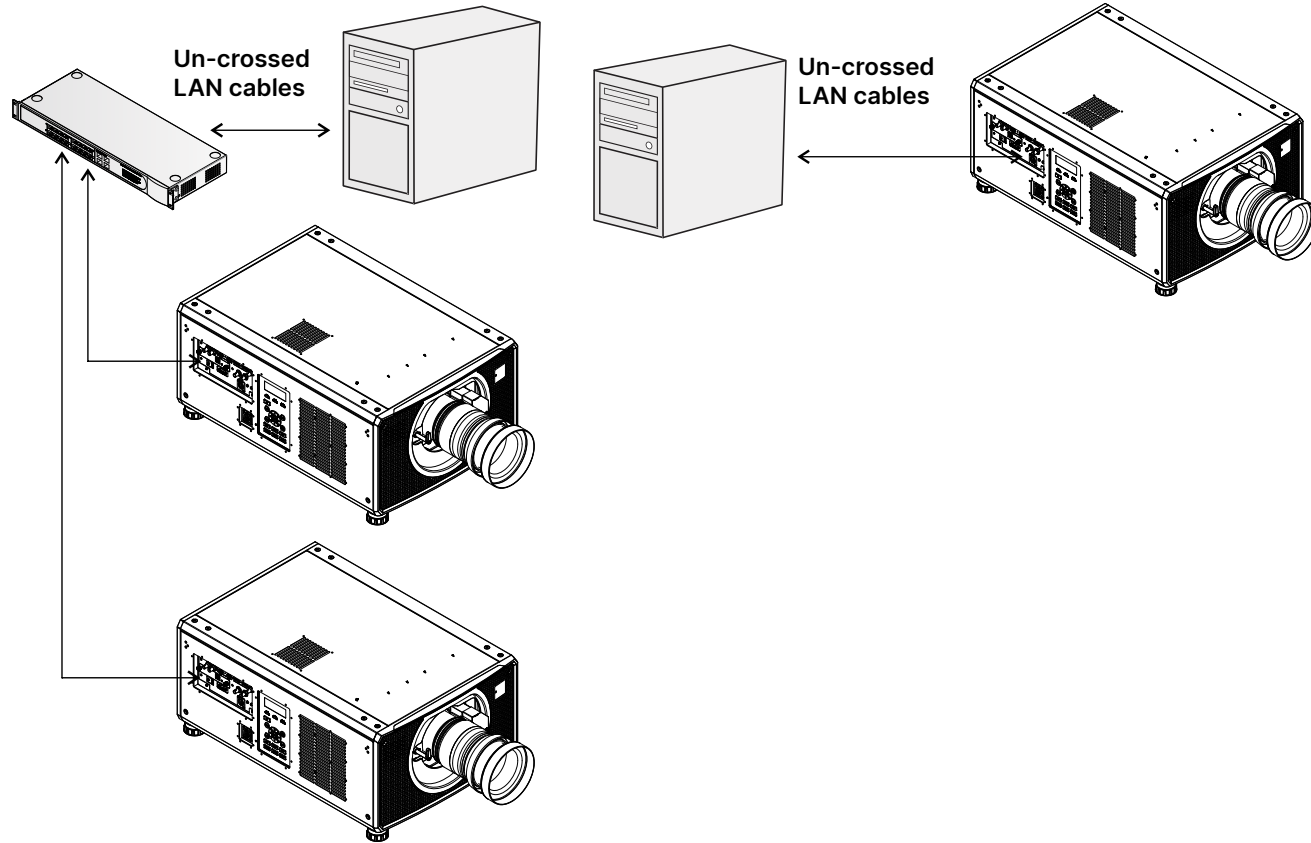
The projector's features can be controlled via a LAN connection, using Digital Projection's **Projector Controller** application or a terminal emulation program.



Notes

-  *With a LAN connection the projector can serve a web page offering basic projector controls.*
-  *Projector Controller is available for download, free of charge, from the Digital Projection website.*
-  *For simultaneous HDBaseT and LAN connectivity, a third-party distribution product can be utilised to combine HDBaseT video stream with LAN connection for delivery to the projector.*

RS232 connection example

All of the projector's features can be controlled via a serial connection, using commands described in the **Protocol Guide**.

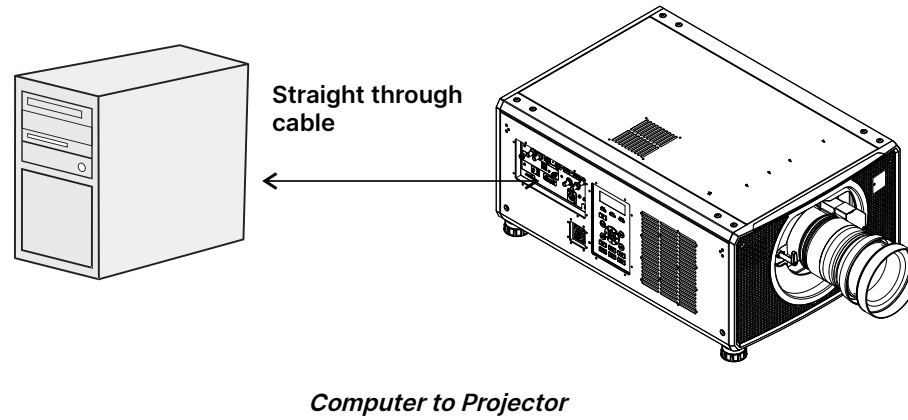

Notes



The Protocol Guide is available separately.

DIGITAL **PROJECTION**

A brand of  **DELTA**

TITAN Luma 35000 4K+ & 37000 WU

High Brightness Digital Video Projector

OPERATING GUIDE



Using the menus

Opening the Menu

Access the various menus using either the projector control panel or the remote control. On either device:

1. Press the **MENU** button.

The on-screen display(OSD) opens showing the list of available menus

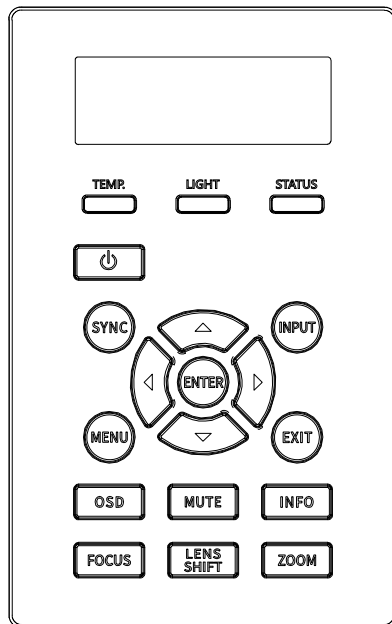

Projector control panel

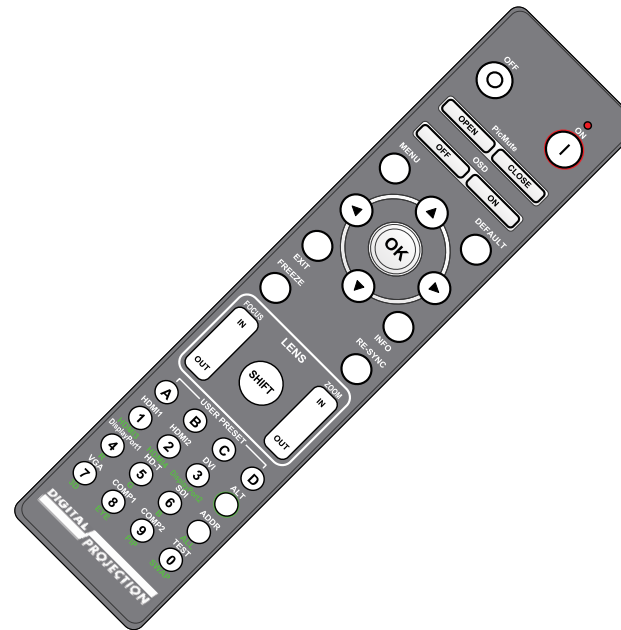

Remote control

Opening a submenu

Move up and down the list using the **UP** and **DOWN** arrow buttons. To open a submenu:

1. Press **ENTER** on the control panel or **OK** on the remote control.

This guide refers to the above two buttons as **ENTER/OK**.

Notes

Exiting menus and closing the OSD

To go back to the previous page:

- Press **EXIT**.

To close the OSD:

- Press **MENU**.

Or:

1. Go back to the top level menu
2. Press **EXIT**.

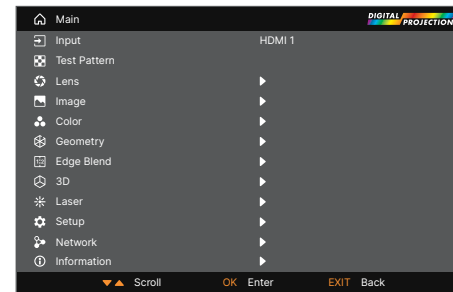

On Screen Display (OSD): Top Level Menu

Inside a menu

When you open a menu, the page consists of the following elements:

- Title bar at the top shows which menu you have accessed.
- Highlighted item
- Available and unavailable items.
Unavailable items appear a pale gray colour.
Whether an item is available may depend on other settings.
- The text or symbol to the right of an item shows whether the item:
 - has a value that can be changed (the current value is shown)
 - opens a sub-menu (an arrow button is displayed)
 - executes a command (the space to the right of the item is blank).

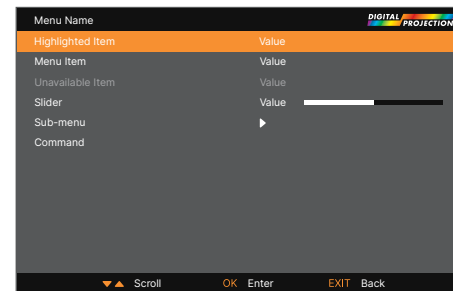

Inside a menu

Notes



The highlighted item has an orange background.

Accessing sub menus

Use the **UP** and **DOWN** arrow buttons to highlight the sub-menu, then press **ENTER/OK**.

Executing commands

If the item contains a command, highlighting it reveals an **OK** button.

Press **ENTER/OK** to execute the highlighted command.

You may be asked for confirmation. Use the **ENTER/OK** to confirm, or **EXIT** to cancel.

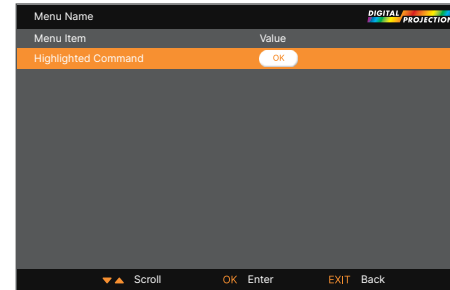

Highlighted Command

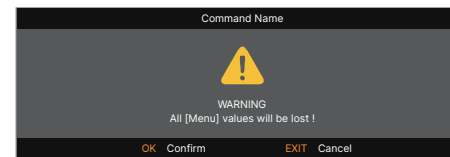

Confirmation Dialog

Notes

Editing projector settings

If the highlighted menu item contains a list of values to choose from, you can change the value by doing the following:

1. Highlight the menu item and press **ENTER/OK**.
2. In the list of values that opens, use the **UP** and **DOWN** arrow buttons to highlight a value, then press **ENTER/OK** again to select the highlighted value.

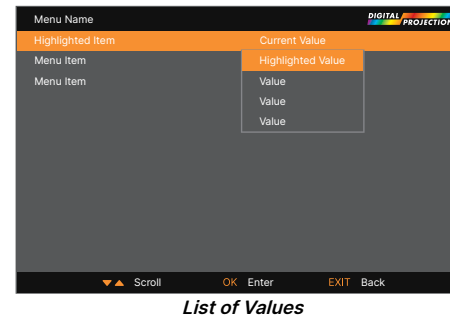

Using a slider to set a value

Some parameters open a slider. To set such a parameter:

1. Press the **LEFT** or **RIGHT** arrow button, or **ENTER/OK**. The arrow buttons will open the slider and adjust the value at the same time. **ENTER/OK** will open the slider without altering the initial value.
2. Use the **LEFT** and **RIGHT** arrow buttons to move the slider.
3. When ready, press **EXIT** to exit the slider and return to the menu, or press **MENU** to exit the slider without showing the menu again.

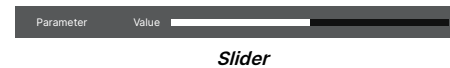

Notes



Some menu items may be unavailable due to settings in other menus. Unavailable menu items appear gray.

Editing numeric values

Some parameters take numeric values without using sliders - for example, color matching values or IP addresses.

1. Use the **UP** and **DOWN** arrow buttons to highlight the row containing the numeric field you wish to edit.
2. Press **ENTER/OK** to enter edit mode. A numeric field in edit mode is white text on blue background.
3. In edit mode:
 - Use the **UP** arrow button to increase the numeric value.
 - Use the **DOWN** arrow button to decrease the numeric value.
4. Use the **LEFT** and **RIGHT** arrow buttons to edit the next or previous numeric fields within the same row.
5. Once ready, press **ENTER/OK** to exit edit mode.

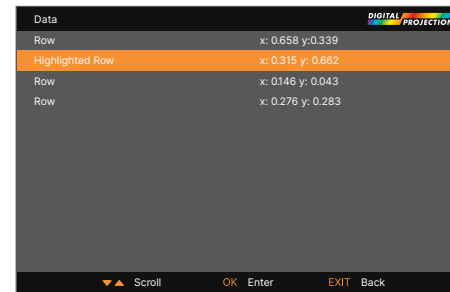

Notes

Using the projector

Main menu

- **Input**
Press **ENTER/OK** to open this menus and access various settings.
- **Test Pattern**
Choose from: Off, White, Black, Red, Green, Blue, Checkerboard, Crosshatch, Color Bar, Aspect Ratio. Use the **LEFT** and **RIGHT** arrow buttons to switch between values.
- **Lens, Image, Color, Geometry, Edge Blend, 3D, Laser, Setup, Network and Information.**
Press **ENTER/OK** to open these menus and access various settings.

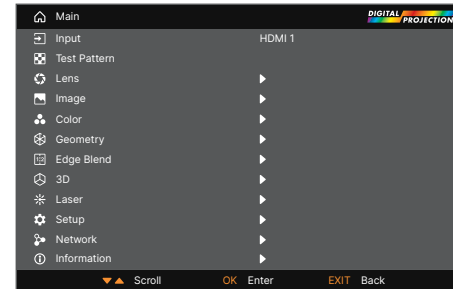

Input menu

- **Input**
Opens a sub-menu, see below.
- **Backup Input Setting**
Backup Mode: Use the **LEFT** and **RIGHT** arrow buttons to select On or Off.
Backup Input Select: Use the **LEFT** and **RIGHT** arrow buttons to select HDMI or DisplayPort.
- **HDMI Equalizer**
Sets a suitable value to maintain the HDMI picture quality in long distance data transmission
- **Resync**
To automatically synchronize the projector to the input source.

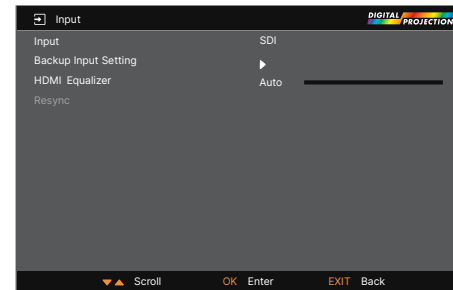

Input

Press **ENTER/OK** to open the list of available inputs.

Use the **UP** and **DOWN** arrow buttons to select an input from the list: **HDMI1, HDMI2, DisplayPort1, DisplayPort2, HDBaset** and **SDI**.

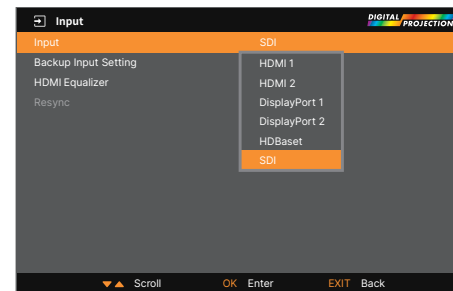

Notes



Selecting a test pattern hides the OSD. Press **EXIT** to hide the test pattern, and then press **MENU** to show the OSD.



See "Signal inputs" on page 34 for information about the available inputs and connections.

Lens menu

- **Lens Lock**
When this feature is **On**, all other Lens menu items are disabled.
- **Lens Control**
Opens a sub-menu, see below.
- **Lens Type**
Choose the lens throw ratio type as fitted to the projector.
- **Center Lens**
Centers the lens.
- **Lens Memory**
Opens a sub-menu, see next page.

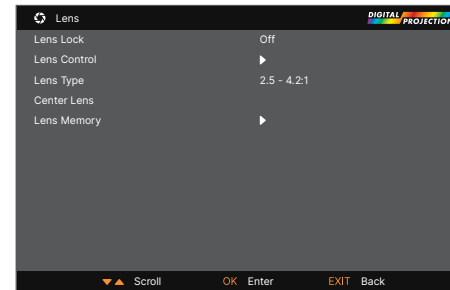

Lens control

Lens Control settings operate in **Zoom/Focus Adjustment** and **Shift Adjustment** mode. Press **ENTER/OK** to switch between modes.

When in **Zoom/Focus Adjustment** mode:

- Use the **UP** and **DOWN** arrow buttons to adjust **Zoom**.
- Use the **LEFT** and **RIGHT** arrow buttons to adjust **Focus**.

When in **Shift Adjustment** mode, use the arrow buttons to adjust **Shift**.

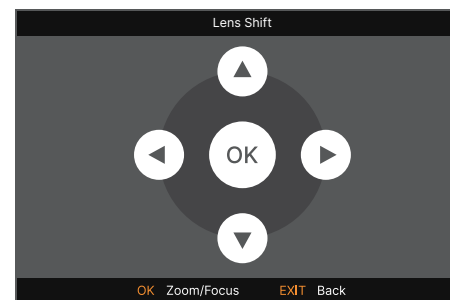
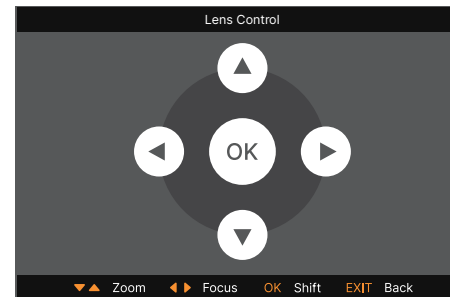

Notes



If focus cannot be achieved using the focus feature, press Shift & 7 on the remote control to adjust for far focus, or Shift & 8 to adjust for near focus.

Lens memory

This menu allows you to load, save and delete up to ten lens presets, containing position, zoom, focus and shift adjustment information.

For example, if using different screen sizes and aspect ratios, you can save zoom, focus and positioning for each screen size and aspect ratio in a dedicated preset.

Use **Clear Memory** to delete a memory preset if you need to save a new combination of lens settings in its place. Overwriting a saved memory preset is not possible.

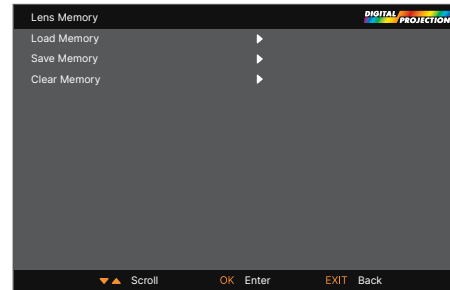

Notes

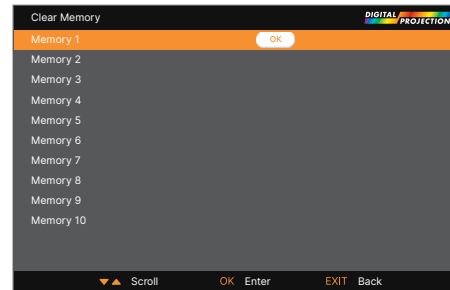
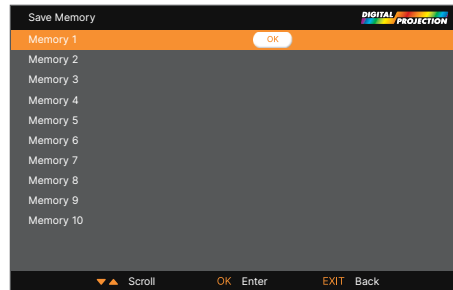
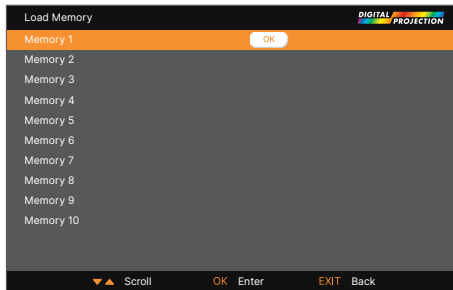

Image menu

- **Dynamic Black**

Set to On to allow for increased contrast in darker scenes by modulating the light source.

- **Light Off Timer**

When **Dynamic Black** is **On**, the **Light Off Timer** will define if laser light source will turn off after a period of time has passed. The options are: **Disable, 0.5, 1.0, 1.5, 2.0, 3.0, 4.0** seconds.

- **Smooth Picture**

On: Display resolution 4K+.

Off: Display resolution WUXGA.

- **Gamma**

Choose a de-gamma curve from **1.0, 1.8, 2.0, 2.2, 2.35, 2.5** and **DICOM**.

Used correctly, the **Gamma** setting can improve contrast while maintaining good details for blacks and whites. If excess ambient light washes out the image and it is difficult to see details in dark areas, lower the **Gamma** setting to compensate. This improves contrast while maintaining good details for blacks. Conversely, if the image is washed out and unnatural, with excessive detail in black areas, increase the setting.

DICOM is a simulated DICOM display, which can be used for training applications.

- **HDR**

Choose from **Off, AUTO, PQ-400, PQ-500, PQ-1000** and **HLG**.

HDR (High Dynamic Range) is a new form of gamma developed to create more realistic experience when viewing images delivered using this format, such as scenes with bright sunlight. Unlike traditional gamma HDR is not device or installation independent. HDR content will come with a recommended brightness regardless of screen size. For best results as a guideline the following screens sizes are suggested.

HDR Screen sizes	Lumens	Screen width (cm)			
		400 NIT	500 NIT	1000 NIT	4000 NIT
Model					
TITAN Luma WU	37000	648	580	410	205
TITAN Luma 4K+	35000	668	597	422	211

HDR options should only be used with media players and sources equipped with HDR and HDR content.

Perceptual Quantizer (PQ) is the digitizing concept for capture and display and provides metadata to enable the display to understand the coding of the content.

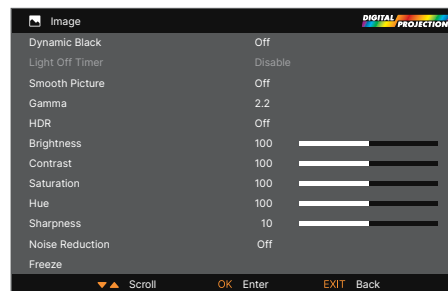

Notes



Image > Dynamic Black, Brightness, Contrast, Saturation, Hue, Sharpness, Noise Reduction, Freeze.
Smooth Picture is not available with the 35000 WU model.

Color > Color Space.

Geometry > Aspect Ratio, Digital Zoom, Overscan.

Setup > Screen Setting, Auto Source, Trigger.



If the HDR setting is Auto, the Gamma setting is only disabled when the image source is HDR



The HDR AUTO setting is only available when the incoming signal is HDR capable

The NIT numbers relate to the brightness of the viewing conditions in NIT. NIT is the unit of brightness measurement for monitors and LED walls that emit light rather than reflect it such as a projection screen. However it is a reference to the brightness you would choose for a given environment.

HDRHLG is High Dynamic Range – hybrid-log-gamma. This is a broadcast version of HDR for live TV and events.

- **Brightness, Contrast, Saturation, Hue, Sharpness**

Highlight the setting you wish to edit, and then press ENTER/OK, or the **LEFT** or **RIGHT** arrow button to open the slider. Use the **LEFT** and **RIGHT** arrow buttons to adjust the slider.

Press **EXIT** to close the slider and return to the menu, or **MENU** to close the slider and return to the projected image.

- **Noise Reduction**

Choose a level of noise reduction from **Off** and **On**.

- **Freeze**

Freezes the current frame.

Notes

Color menu

Color space

In most cases, the Auto setting determines the correct colorspace to use. If it does not, you can choose a specific colorspace:

Choose from **Auto**, **YPbPr**, **YCbCr**, **RGB PC** and **RGB Video**.

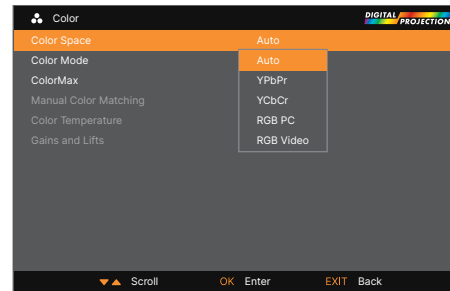
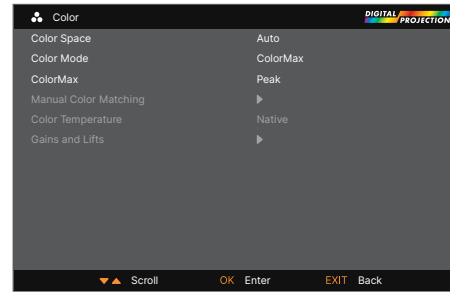

Notes

Color mode

The projector can work in the following color modes: **ColorMax**, **Manual Color Matching**, **Color Temperature** and **Gains and Lifts**.

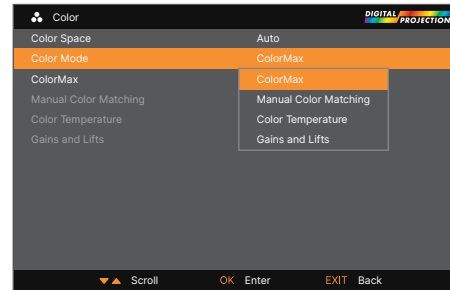

Notes



Only one color mode can be selected at a time. Settings used by the other color modes are disabled.

ColorMax

1. Set Color Mode to ColorMax.
2. Navigate to the ColorMax setting.
3. Choose from **Peak**, **REC709**, **User 1** and **User 2**. **User 1** and **User 2** are user-defined color gamuts set via the **Setup > ColorMax** menu.

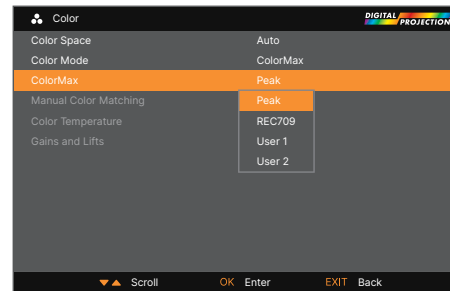

See "Setup menu" on page 75 for further information about setting up the User 1 and User 2 color gamuts.

Manual color matching

1. Set **Color Mode** to **Manual Color Matching**.
2. Open the **Manual Color Matching** submenu.

Here you can do the following:

- Switch **Auto Test Pattern** On and Off.
- Adjust **Hue**, **Saturation** and **Gain** settings for each individual color to improve the color balance of the projected image.
- Adjust white balance RGB values.
- Reset all values.

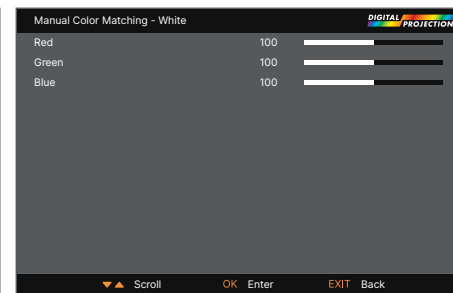
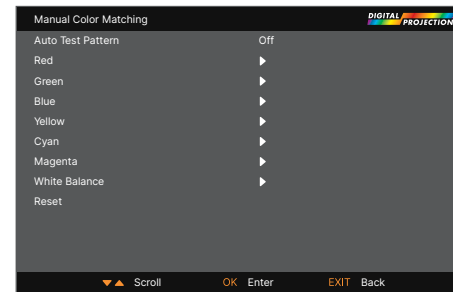

Notes

 See "Color matching parameters explained" for more details about the Hue, Saturation and Gain settings.

Color matching parameters explained

The levels of hue, saturation and gain in the Manual Color Matching menu can change the color values in the following ways:

1. **Hue** Specifies the position of each color (red, yellow, green, cyan, blue and magenta) relative to its neighboring colors.
2. **Saturation** Specifies the level of white in each color (i.e. how "pale" each color is).
3. **Gain** Controls the amount of light that goes into each color, i.e. the lowest gain would produce black.

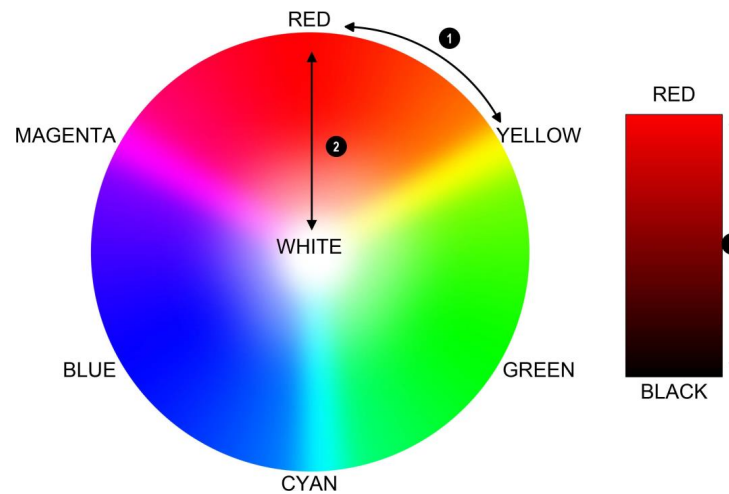

Color temperature

1. Set **Color Mode** to **Color Temperature**.
2. Navigate to the **Color Temperature** setting. Choose a value from **3200K** (warmer) to **9300K** (cooler) or **Native** (no correction).

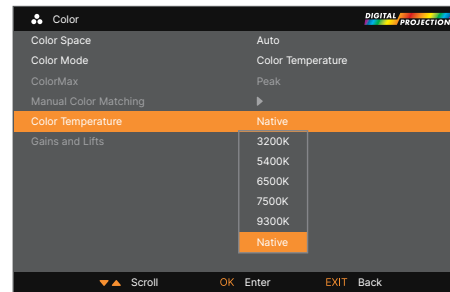

Gains and lifts

1. Set **Color Mode** to **Gains and Lifts**.
2. Open the **Gains and Lifts** submenu.

Lifts allow you to adjust black levels of individual colors, while gains adjust the bright part of the scale. Set the sliders as required

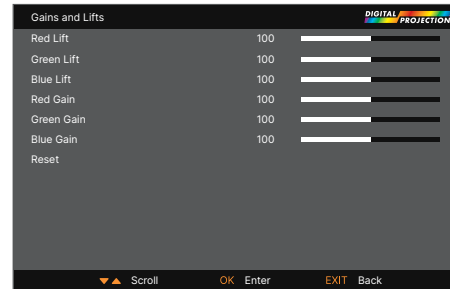

Notes

Geometry menu

This menu allows you to compensate for image distortions caused by an unusual projection angle or irregular screen surface.

Aspect ratio

This feature defines the aspect ratio of the source. Use the **Setup > Screen Setting** to define the screen aspect ratio. If you choose a preset aspect ratio from here, it will give you the best fit for your selection.

Choose from:

- 5:4
- 4:3
- 16:10
- 16:9
- 1.88
- 2.35
- TheaterScope
- Source
- Unscaled

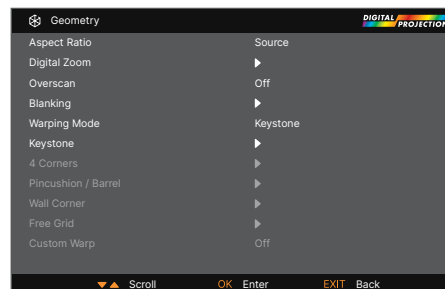

Notes



Select a **Warping Mode** to activate it. Access its submenu to adjust the warping mode settings.



Image scaling and aspect ratio are also influenced by **Setup > Screen Setting**.



See "Theaterscope setting" on the next page for further information about the TheaterScope aspect ratio.

Theaterscope setting

The **TheaterScope** setting is used in combination with an anamorphic lens to restore 2.35: images packed into a 16:9 frame. Such images are projected with black lines at the top and bottom of the 16:9 screen to make up for the difference in aspect ratios.

Without an anamorphic lens and without the TheaterScope setting applied, a 16:9 source containing a 2.35:1 image looks like this:

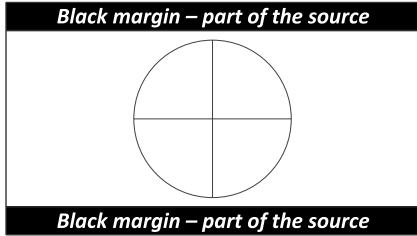

If we change the setting to TheaterScope, the black lines will disappear but the image will stretch vertically to reach the top and bottom of the DMD™:

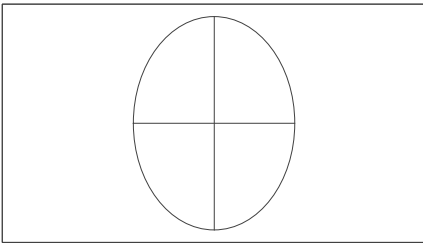

An anamorphic lens will stretch the image horizontally, restoring the original 2.35 ratio:

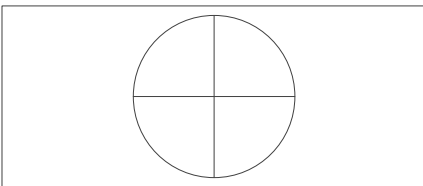

Notes



TheaterScope is used with an anamorphic lens.



If you use TheaterScope, set your screen aspect ratio to 16:9.

Digital zoom

Digital zooming enlarges a section of the image, while the area outside the enlarged section is cropped out to preserve the overall image size.

- **Digital Zoom** defines the level of zoom that needs to be applied. If **Digital Zoom** is set to 0, then the other settings in the menu will be disabled.
- **Digital Pan** and **Digital Scan** specify the area that is being enlarged:
 - **Digital Pan** adjusts the horizontal coordinates.
 - **Digital Scan** adjusts the vertical coordinates.

The **Reset** command restores the default **Digital Zoom**, **Digital Pan** and **Digital Scan** values.

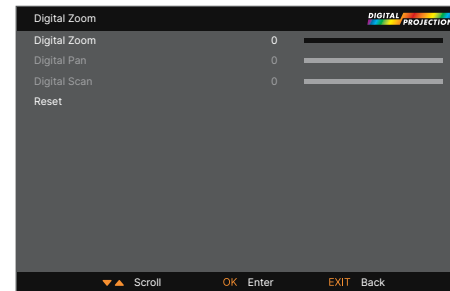

Notes



Digital Zoom is a temporary setting and not retained after an input change or power cycle.

Overscan

Use this setting to compensate for noisy or badly defined image edges.

Crop removes unwanted artifacts from the edges of your image by cropping the edges.

Zoom increases the size of the image to force the edges off-screen

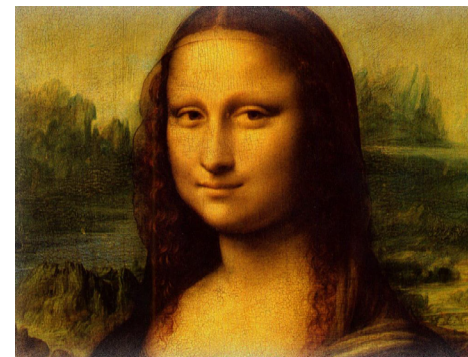
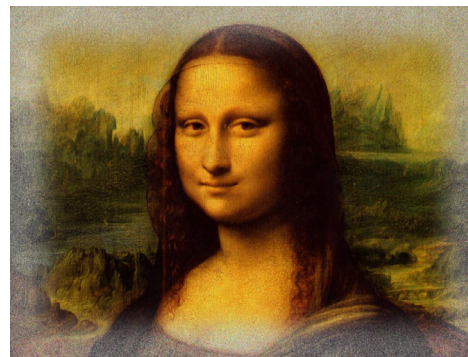
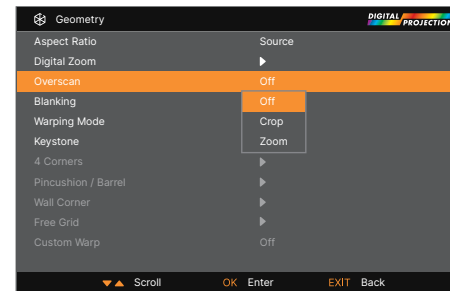

Blanking

Use this feature to:

- fit an odd-sized screen;
- cut off timecode dots in the top line of a picture;
- cut off subtitles, etc.

Select the edge you wish to blank and use the **LEFT** and **RIGHT** arrow buttons to determine the amount of correction.

Use the **Reset** command to restore blanked edges.

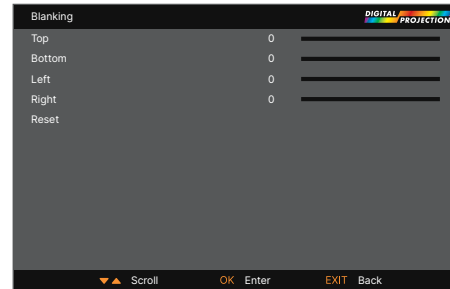

Notes

Warping Modes

Seven modes can be selected: Off, Keystone, 4 Corner, Pincushion/Barrel, Wall Corner, Free Grid and Custom Warp.

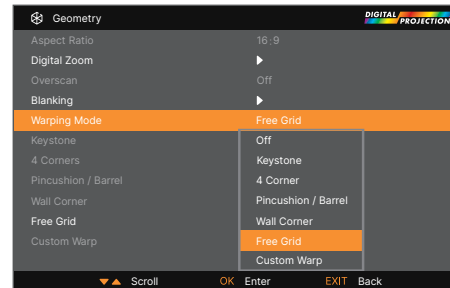

Keystone

Use this setting to compensate for any distortion caused by the projector being in a different horizontal or vertical plane to the screen.

After correcting for keystone, the aspect ratio of the projected image may be incorrect. This is dependent upon the throw ratio of the lens at its current zoom setting. Adjust the lens throw ratio to compensate for the aspect ratio that results from the zoom setting on the lens.

Keystone example

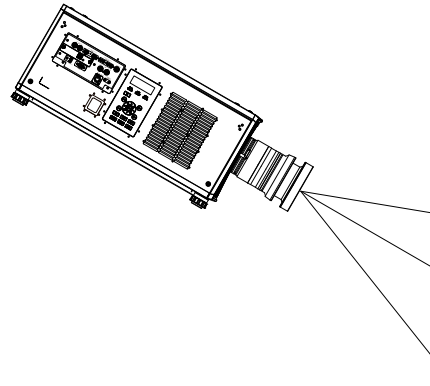

The projector is positioned at an angle

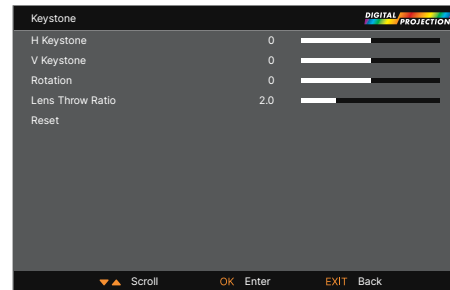

The resulting image is distorted



The image is corrected when Keystone is applied, but the aspect ratio is incorrect

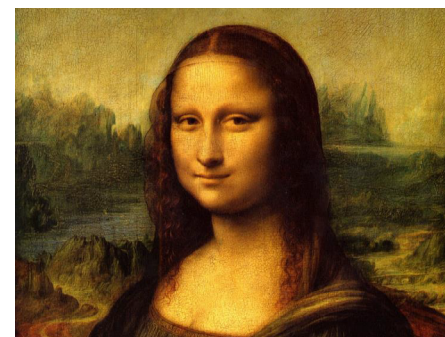

The aspect ratio is corrected when the correct lens throw ratio is applied

Notes



Max rotation in Keystone is reduced from normal rotation.



Make sure that the lens type is set to the correct lens in the lens menu before adjusting the lens throw ratio.

Keystone settings

1. **Projector to the left** The projector is positioned to the left of the screen. To correct, apply a positive **Horizontal Keystone** value using the **RIGHT** arrow button.
2. **Projector to the right** The projector is positioned to the right of the screen. To correct, apply a negative **Horizontal Keystone** value using the **LEFT** arrow button.
3. **Projector high** The projector is positioned above the screen at a downward angle. To correct, apply a negative **Vertical Keystone** value using the **DOWN** arrow button.
4. **Projector low** The projector is positioned below the screen at an upward angle. To correct, apply a positive **Vertical Keystone** value using the **UP** arrow button.
5. **Projector straight** The projector is directly opposite the screen at a right angle both horizontally and vertically. No correction is needed.

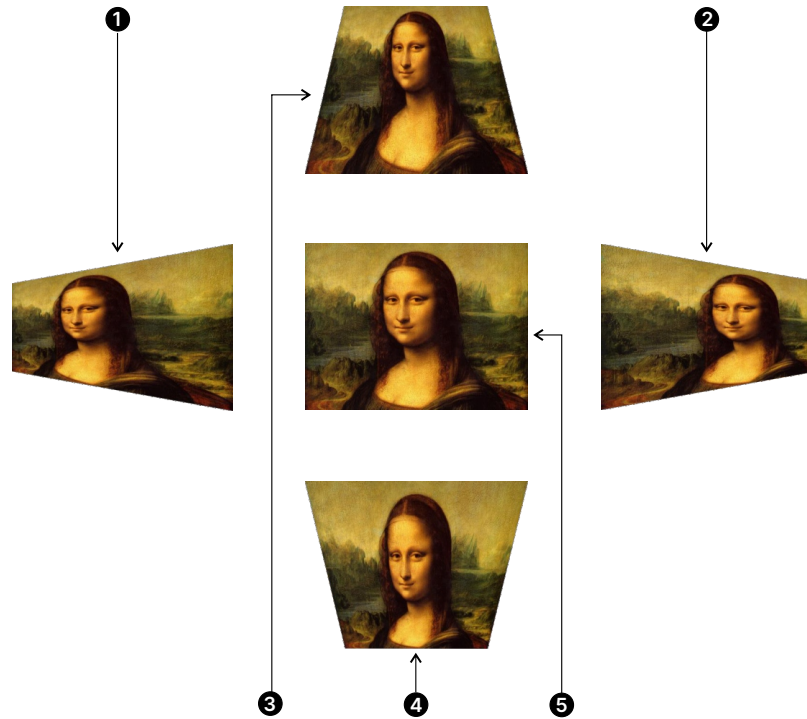
*Horizontal and vertical keystone corrections*

Notes

4 corners

For each corner, apply horizontal and / or vertical correction as necessary to restore the rectangular shape of the image.

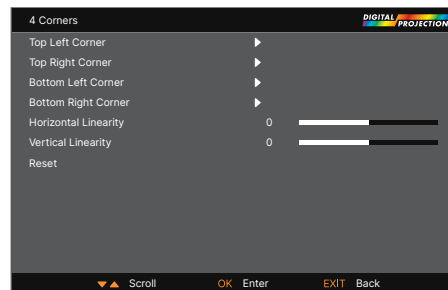

Top right corner example

In this illustration, the top right corner requires both horizontal and vertical correction.

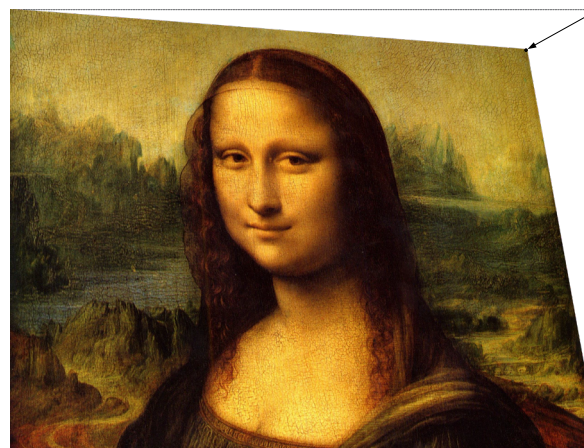
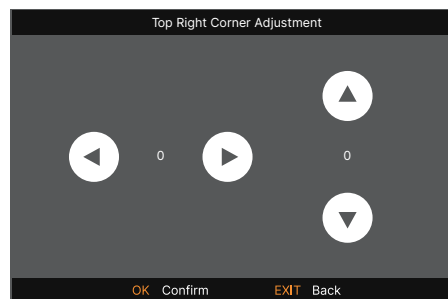

Notes



Corner corrections provide a simple setup for awkward installations and irregular shaped screens that may distort the image. To apply a similar (but less flexible) correction, while preserving the original aspect ratio of the image, use the Keystone menu.

Pincushion / Barrel

Pincushion or barrel distortions are the result of poor or incorrect tensioning of the screen or using a surface that is not flat.

Use the **Pincushion / Barrel** control to compensate electronically for such distortions.

You can also use this menu to make simple panoramic screen corrections without using external processors.

When also correcting for keystone, the aspect ratio of the projected image may be incorrect. This is dependent upon the throw ratio of the lens at its current zoom setting. Adjust the lens throw ratio to compensate for the aspect ratio that results from the zoom setting on the lens.

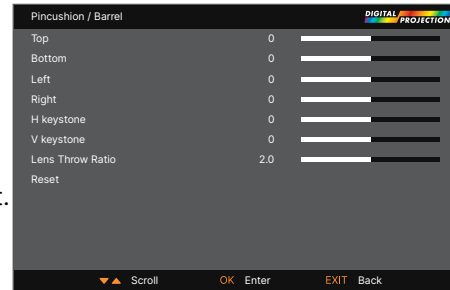

Notes



Make sure that the lens type is set to the correct lens in the lens menu before adjusting the lens throw ratio.

Pincushion/ Barrel example

The illustration shows pincushion and barrel correction applied both horizontally and vertically, in equal measures. .

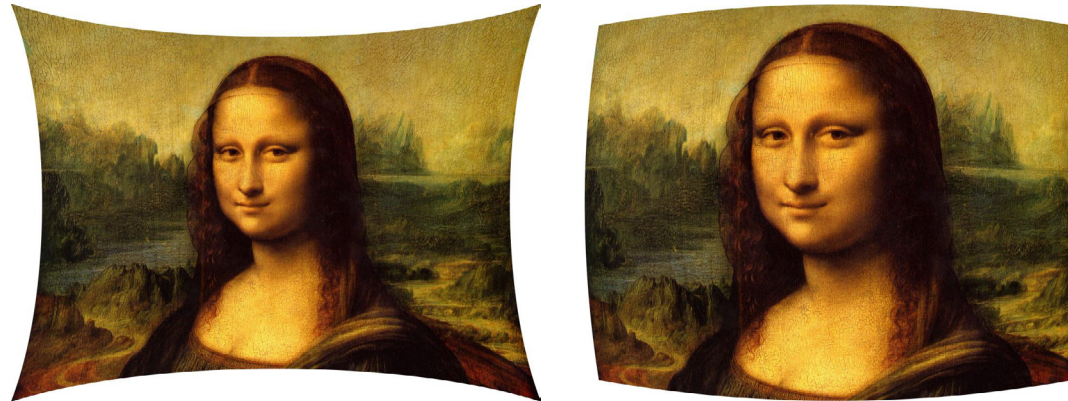

Wall Corner

The Wall Corner feature allows for geometric adjustment when projecting onto a surface with a horizontal or vertical external or internal angles.

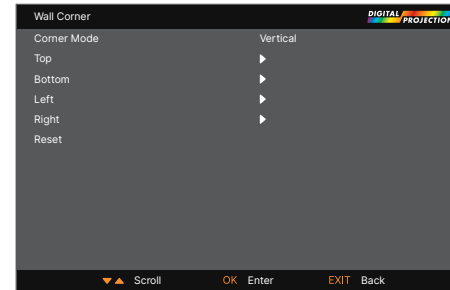

Notes



Top / Bottom only available when select "Corner Mode" to Horizontal.

Left / Right only available when select "Corner Mode" to Vertical.

Free Grid

The Free Grid feature provides non-linear curvature correction for curved or spherical screens and other irregular shaped surfaces such as building mapping.

The grid overlay of this feature can be manipulated from the projectors keypad or IR Remote Control Unit without using the Digital Projection Projector Controller software



Free Grid must be enabled in order to set User 1 and 2 custom warp.

Custom warp

This feature permits selection of predefined User warp maps. Use the Projector Controller PC application to create the custom warp maps.

Custom warp maps provide non-linear curvature correction for curved or spherical screens and other irregular shaped surfaces such as building mapping.

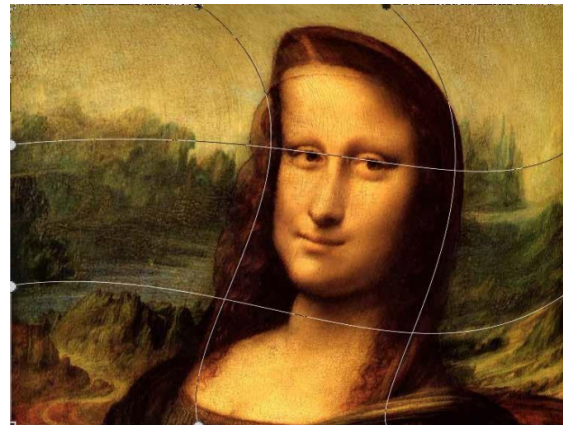
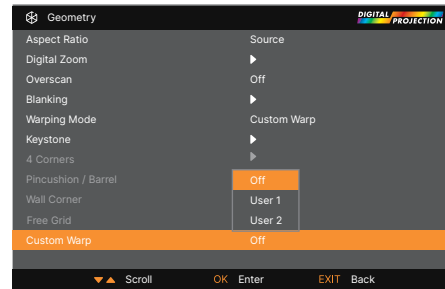

Notes

Edge blend menu

Use this menu to blend together images from an array of two or more projectors. The feature feathers the light output of the projector within the edges that overlap with other projectors in the array: as a result, the overlapping edges are evenly lit and easily blend in with the rest of the image.

- **Edge Blend Mode**

Enable and disable **Edge Blend**

- **Align Pattern**

Add markers to the image showing the edges of the blend area and making the overlaps more visible to help adjust the physical position of the projectors in the array.

- **Blend Start**

Determine the start point of the blended regions. top, bottom, left right.

- **Blend Width**

Determine the width of the blended regions.

- **Black Level Uplift**

Adjust black levels to compensate if the blended regions appear brighter than the rest of the image.

- **Reset**

Reset all **Edge Blend** settings to their factory default values.

- **Uniformity**

Open the Sub-menu for more detailed information.

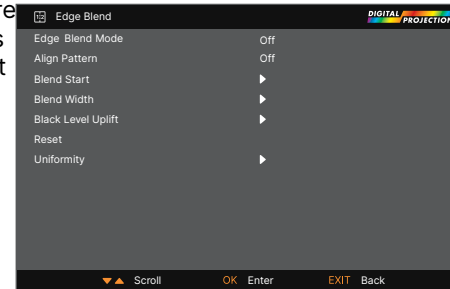

Notes



When Edge Blend is set to Off, all other edge blend settings are disabled.



The picture in the blend region needs to be delivered to all overlapping projectors, which may require a special setup of the sources.



See "Uniformity" on page 69.

Blend start

Use the blend start options to deactivate pixels at the edge of the image and set the start point for the blended region. Use the **LEFT** and **RIGHT** arrow buttons to set the start point of the blended regions:

1. Top
2. Bottom
3. Left
4. Right

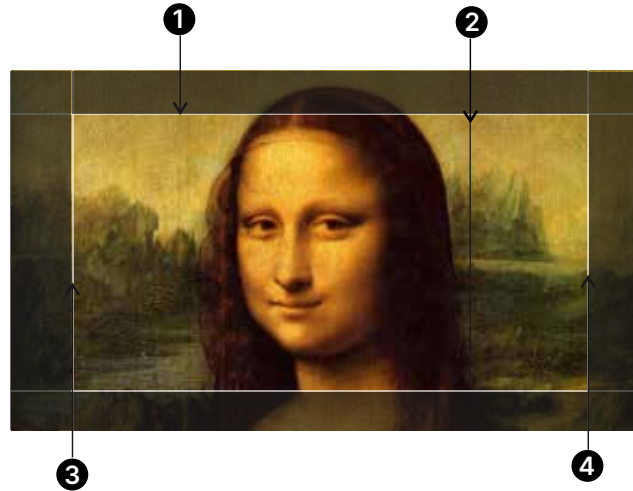
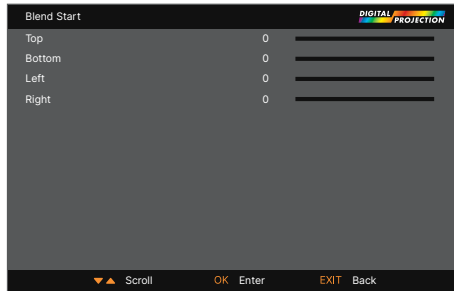

Blend width

Use the **LEFT** and **RIGHT** arrow buttons to set the width of the blended regions:

1. Top
2. Bottom
3. Left
4. Right

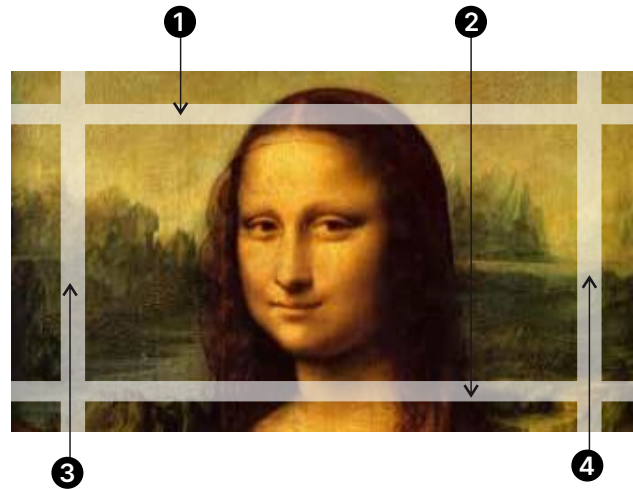
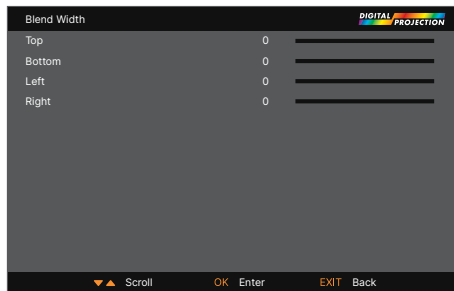

Notes

Black level uplift

Black in the blended regions appears less dark than in the rest of the image. To compensate for this, use this menu to raise the black levels of the rest of the image:

- Set **All** to the required amount of black level correction. This will apply equal correction to the black levels of all colors
- If necessary, use the individual color sliders (**Red, Green and Blue**) for fine adjustment.

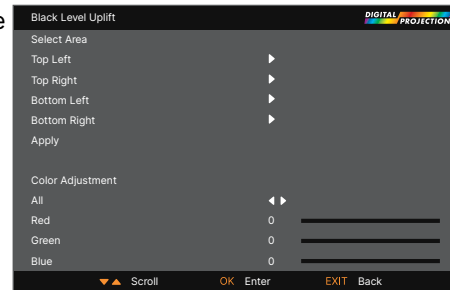

You may experience artifacts at the edges where the blended region of one projector overlaps the **pond of mirrors** of its neighbor. In the example below, the blended image comes from **two projectors**, **1** and **2**. Both images have black level uplift applied; as a result, **artifacts 3** and **4** have emerged at the edges where the black level uplift region of one projector overlaps the pond of mirrors of the other.

To remove the artifacts, you need to slightly reduce the size of the black level uplift region of each projector so it does not overlap the pond of mirrors of the other projector.

- Depending on your array, use **Top, Bottom, Left** and/or **Right** to reduce the black level uplift size. In the example below, use the **Right** slider of the **projector on the left 1** to remove the **artifact on the right 4**, and the **Left** slider of the **projector on the right 2** to remove the **artifact on the left 3**.

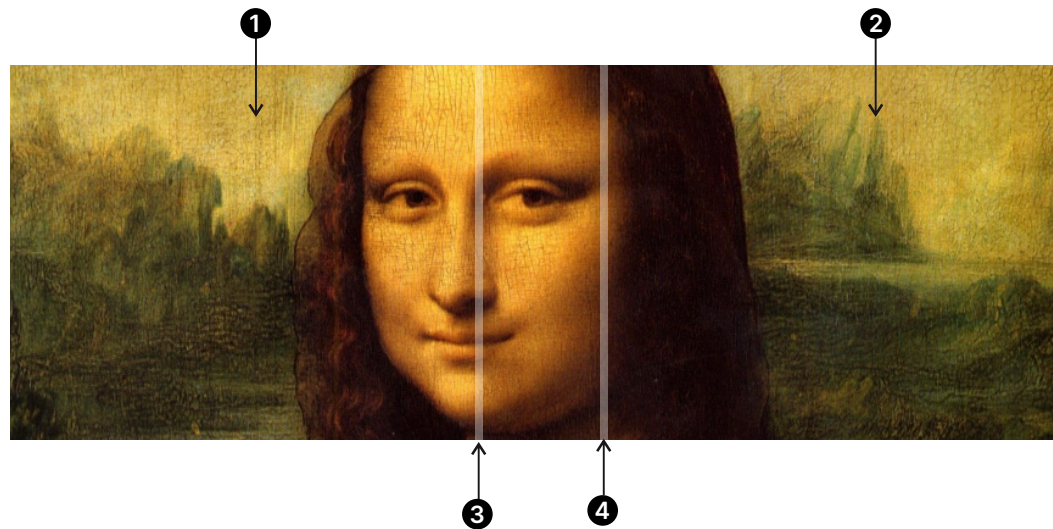

Notes



Enable **Align Pattern** from the **Edge Blend** menu to see the **black level uplift area**.

Uniformity

Mode: Enable Color uniformity correction.

Location X: Select the block area from X axis.

Location Y: Select the block area from Y axis.

Red Gain: Adjust the Red color gain on the selected block area

Green Gain: Adjust the Green color gain on the selected block area

Blue Gain: Adjust the Blue color gain on the selected block area

Reset: All the Uniformity settings will be reset to the default settings.

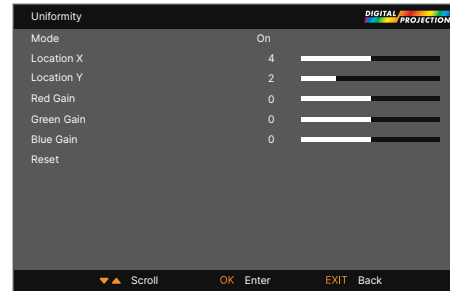

Notes

3D menu

Use this menu to enable, disable and set up 3D input, as follows:

- **3D Format**

Off, Auto, Side by Side, Top and Bottom, Dual Pipe, Frame Sequential and Frame Packing.

Off: Turn off the 3D Display Mode. When Auto, Side by Side, Top and Bottom, or Frame Sequential is selected, the 3D Mode will be turned on. To turn off the 3D Mode, select "Off" and press "ENTER".

Auto: Allow the 3D format to automatically detect the formats of Frame Packing, Top and Bottom, and Side by Side. The input signal is HDMI 1.4b 3D.

Side by Side (Half): This option is only applicable to input signal HDMI 1.4b 3D or HDMI signal sent by HDBaseT Transmitter.

Top and Bottom: This option is only applicable to input signal HDMI 1.4b 3D or HDMI signal sent by HDBaseT Transmitter.

Dual Pipe is for sources where Left and Right eye are delivered on separate inputs.

Frame Sequential is for sources where Left and Right eye images are delivered as alternate frames from a single input.

Frame Packing: Set input format under Frame Packing.

- **Eye Swap**

Normal and Reverse.

(set to **Reverse** if the left- and right-eye images are displayed in the wrong order)

- **Dark Time**

0.65 ms, 1.3 ms and 1.95 ms.

Set to reduce the effect of banding and image overlapping when viewed through 3D glasses.

- **Sync Offset**

Use the **LEFT** and **RIGHT** arrow buttons to compensate for image overlapping (ghosting) when viewed through 3D glasses.

- **Sync Reference**

External and Internal.

Select the source of the 3D sync. Internal is referenced to the incoming video.

External is for Frame Sequential 3D sources and is supplied by the graphics card or player.

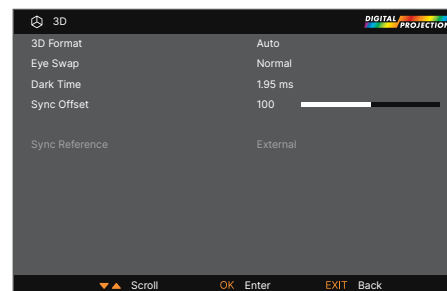

Notes



If 3D Format is set to Off, all other 3D settings will be unavailable.



See "3D connections" on page 36 for more information about supported 3D formats.



*The following settings are not available when 3D is on:
Image > Brightness, Contrast, Saturation, Hue, Sharpness, Noise Reduction, Freeze.
Color > Color Space.
Geometry > Aspect Ratio, Digital Zoom, Overscan.
Setup > Screen Setting, Auto Source, Trigger.*



Also: See "3D types" on page 71 and See Some "Some 3D settings explained" on page 72.



See "3D formats" on page 115 for 3D resolutions and frame rates.

3D types

To display a 3D image if is first necessary to select the 3D format. This can either be Frame Sequential or Dual Pipe. These formats are described below:

- **Dual Pipe (LEFT and RIGHT)** The left and right eye images are delivered on two separate HDMI links, which the projector will interleave for 3D display.
- **Frame Sequential** For sequential 3D, an external sync is required to identify left and right frames. If no sync is available from the sequential source, the projector will generate an output sync, but it may then be necessary to manually set the Eye Swap each time the player is started.

Dark Time and **Sync Offset** need to be set only once, to optimize the image for the glasses in use.

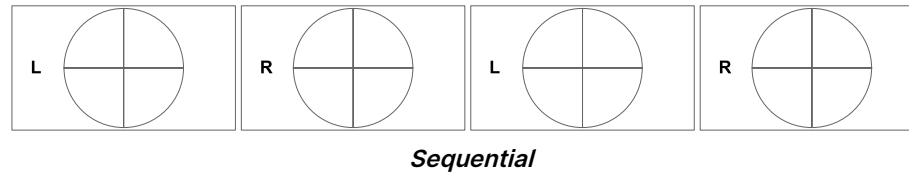
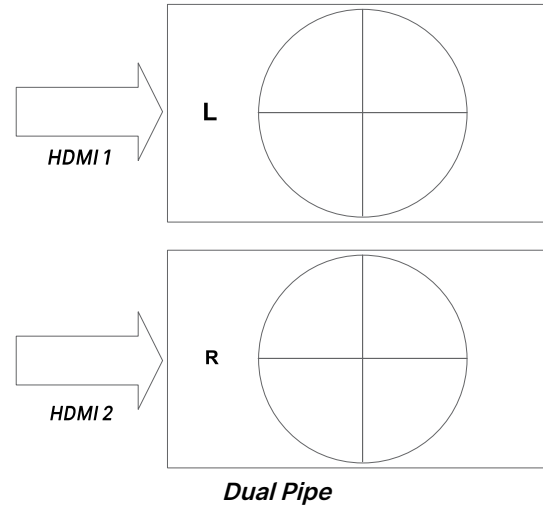

Notes

Some 3D settings explained

Eye swap

The outgoing 3D frames are in pairs - the dominant frame being presented first. You can determine which frame should be the dominant one.

By convention the default setting is **Left**.

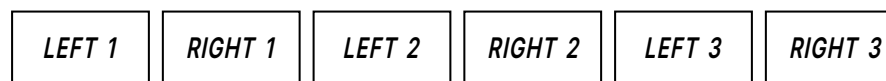

Dominance Left

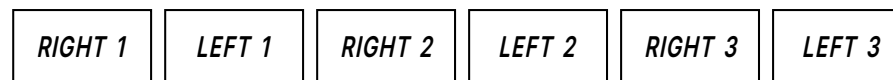

Dominance Right

Dark time

Banding can be caused if the image is displayed before each eye of the 3D switching glasses or ZScreen is not fully open.

Dark Time allows you to minimize this effect. .

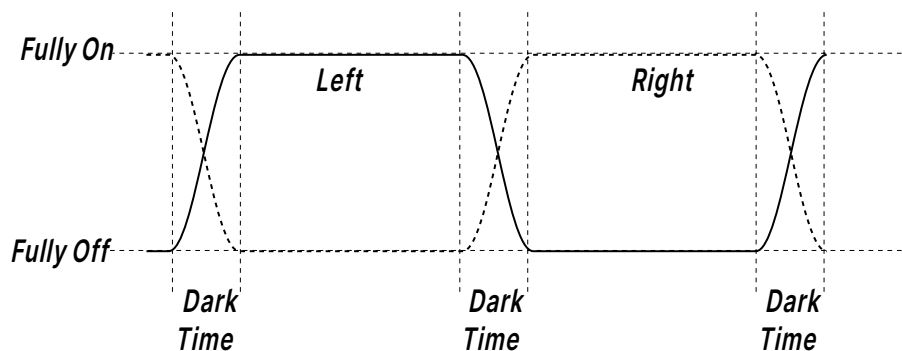

Notes



In order to achieve maximum light output and a smooth grayscale, whilst eliminating ghosting, the following procedure is recommended:

1. *Set Dark Time to a value appropriate to the glasses or ZScreen, say 1.3 ms or 1.95 ms.*
2. *Adjust Sync Offset time to eliminate ghosting and achieve a smooth grayscale.*
3. *Repeat steps 1 and 2 until the best result is obtained.*

Sync offset

The sync signal from the 3D server will be in phase with the frames generated by its graphics card. However, to compensate for switching delays in the glasses or ZScreen, **Sync Offset** is used to adjust the sync output signal sent to the ZScreen or 3D glasses to minimise overlapping (ghosting in the image when viewed through the 3D glasses).

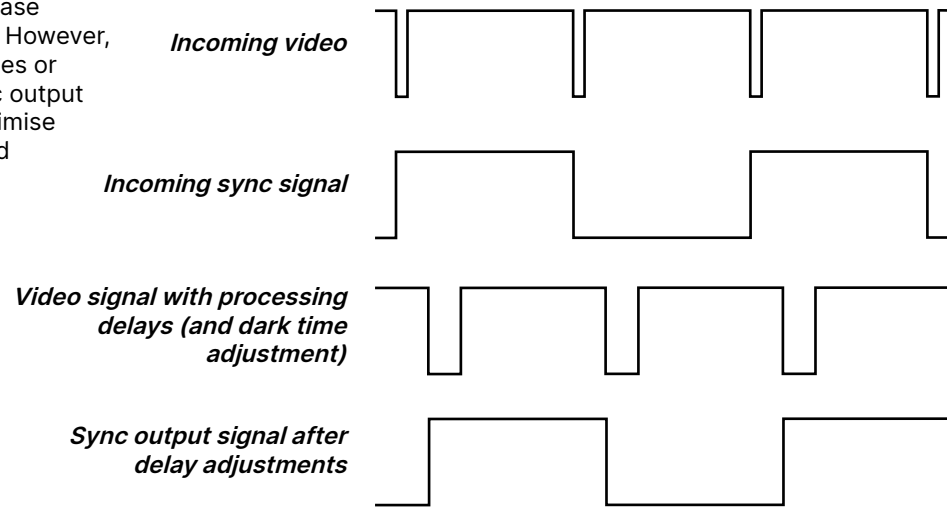

Notes

Laser menu

- **Power Mode**

- **Eco** will automatically set the laser power to 70%.
- **Normal** will set the power to 100%.
- Set to **Custom** if you wish to adjust the power manually.

- **Power Level**

This setting is only available if **Power Mode** is set to **Custom**.
Choose a value between 30 and 100, ranging from 30% to 100% laser power.

- **Constant Brightness**

Once a **Custom Power Mode** has been set, then Constant Brightness can be turned **ON**.

This setting will maintain the brightness until the maximum laser power has been reached. The lower the power level the longer it will be maintained.

- **Brightness Sync Mode**

Available when 'Contrast Brightness' is On, otherwise will be grayed-out.

Off: disable Brightness Sync

On (Master): enable Brightness Sync and act as Master.

On (Slave): enable Brightness Sync and act as Slave.

- **Brightness Sync Group**

Available when Brightness Sync Enable is On, otherwise will be grayed-out.

Each group allows for one master and eight slave members.

- **Brightness Sync Interval**

Available when Brightness Sync Enable = On (Master), otherwise will be grayed-out.

- **Brightness Sync Status**

Grayed-out when Brightness Sync Enable = Off,

When Brightness Sync Enable = On (Master), shows how many Slave connections in this group.

When Brightness Sync Enable = On (Slave), shows the connection status with Master.

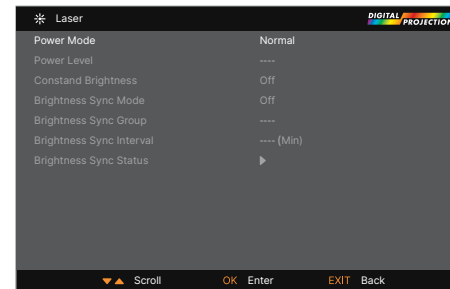

Notes

Setup menu

- **Orientation**

Choose from **Front Tabletop**, **Front Ceiling**, **Rear Tabletop**, **Rear Ceiling** and **Auto-front**.

- **High Altitude**

Choose from **Off**, **On**, **Auto** and **Quiet**.

- **Standby Mode**

Choose from **SuperECO**, **ECO** and **Normal**.
SuperECO uses minimal power and disables power ON via LAN.
ECO uses a low power setting but enables power ON via Ethernet port only.
Normal enables power ON via both HDBase-T/LAN and Ethernet ports.

- **Screen Setting**

Choose from **Screen Format** and **Screen Position**.

- **ColorMax Setting**

Set up user-defined color gamut values.

- **Power On/Off Management**

Access the submenu to set up automatic projector power on and power off.

- **Clock Adjust**

Access the submenu to set current date and local time.

- **Startup Logo**

Choose from **Off**, **Original** and **User**.
 Select original to display the Digital Projection Ltd. logo on startup. Select User to display a custom logo. Use the custom logo upload tool to set the custom logo for the User option.

- **Blank Screen**

Choose from **Logo**, **Black**, **Blue** and **White**.

- **Auto Source**

If this setting is **On**, the projector will automatically search for an active input source.

- **PIC MUTE Setting**

Access sub menu to set up the picture mute control.

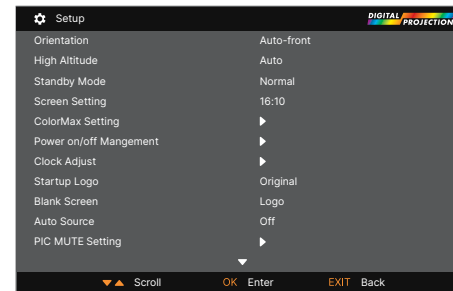

Notes



Auto-front automatically detects the projector's position and sets Table or Ceiling orientation accordingly..



Custom Logo. Please request the Custom Logo Upload Tool from your local Digital Projection Service provider to upload a custom logo.

Highlight the **DOWN** arrow at the bottom of the page and press **ENTER/OK** to navigate to the second Setup menu page.

- **Trigger**

Choose from **Off, Screen, 5:4, 4:3, 16:10, 16:9, 1.88, 2.35, TheaterScope, Source, Unscaled** or **RS232** to determine what will cause each trigger output to activate.

- **Infrared Remote**

Set to **Off** if you wish to disable the remote control.

- **IR Code**

The projector and the remote control need a matching IR code: a two-digit number between **00** and **99**. The default IR code is **00**. This is also a master code, which, if assigned to a remote, will work regardless of the value assigned to the projector.

- **To assign an IR code for the projector:** Select IR code. Use the UP and DOWN arrow buttons to change the values.
- **To assign an IR code for the remote,** press and hold the **ADDR** button on the remote until the On indicator starts flashing. Release the **ADDR** button and while the indicator is still flashing, enter a two digit address using the numeric input buttons. The indicator will flash three times quickly to confirm the change.

- **IR Code Reset**

Use this command to unassign an IR code from the projector. This will revert the **IR Code** value to 00.

To unassign an IR code from the remote control, press and hold **ALT** and **ADDR** simultaneously until the On indicator flashes to confirm the change.

- **OSD Settings**

Access this submenu to adjust the appearance and position of the on-screen display.

- **Memory**

Access this submenu to save up to four presets containing custom combinations of image settings, or to recall a saved preset.

- **EDID Mode**

Access this submenu to set the frame rate and display resolution for each input type.

- **Smear Reduction**

Choose from **Off, 6ms, 7ms, 8ms, 9ms, and 10ms**. When projecting footage with a high frame rate, fast moving images may appear as a smear across the display. Select a smear reduction value to reduce this effect.

- **Output Frame Rate**

Choose from **Auto, 48Hz, 50Hz and 60Hz**. Select Auto to use the same frame rate as the input signal. When switching between inputs on auto output frame rate, the projector measures the input frame rate before setting the output frame rate. When you know that all input frame rates are the same value, you can set an output frame rate to reduce the time it takes to switch between inputs.

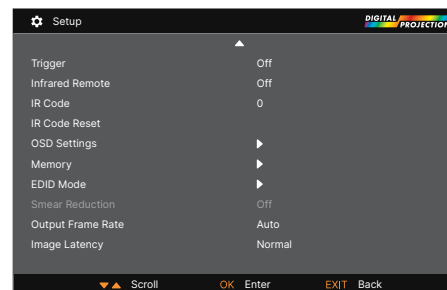

Notes



The Projector Controller software is available for download from the Digital Projection website, free of charge.



A wired remote control will also be disabled if Infrared Remote is set to Off.



Smear reduction is not available for 3D input types.



Smear reduction reduces the brightness of the displayed imagee.

- **Image Latency**

This function allows you to set image latency. Note that normally the image latency should be set to Normal for best picture quality.

Highlight the **UP** arrow at the top of the page and press **ENTER/OK** to go back to the first **Setup** menu page.

Notes

ColorMax

ColorMax permits seven point color matching of red, green, blue, yellow, cyan, magenta and white.

You can enter your own gamut values here, or edit values you have imported using the **Projector Controller** software.

Defining your own colorspace with individual x and y coordinates for each color enables you to match not only the whites but each individual color as well.

Highlight the submenu you wish to open and press **ENTER/OK** to confirm your choice.

Measured data/ target data

1. Use the **UP** and **DOWN** arrow buttons to highlight a color, then use the **LEFT** and **RIGHT** arrow buttons to navigate to the x or y coordinate.
2. Use the **UP** and **DOWN** arrow buttons to increase and decrease the value, respectively.
3. Exit edit mode:
 - press **ENTER/OK**, if you want to save the edited values.
 - press **EXIT**, if you do not wish to save the edited values
4. If necessary, highlight another color and repeat the procedure.

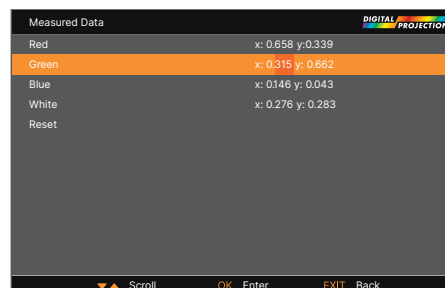
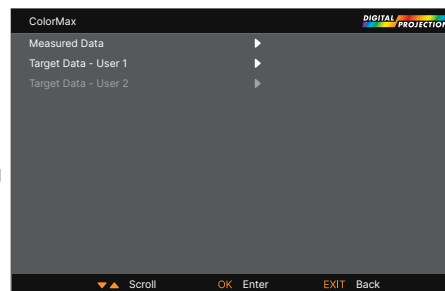

Notes



The Projector Controller software is available for download from the Digital Projection website, free of charge.



This tool is best used in conjunction with a specialized light meter (a photo spectrometer) to measure color parameters within a particular installation. However, the preloaded generic factory default data set is designed to give more than satisfactory results.

Power on/off Management

- **Auto Power Off**

Set this to **On** if you want the projector to go into **STANDBY** mode when no input source is detected for 20 minutes.

- **Auto Power On**

Set this to **On** if you want the projector to start up immediately when the mains is connected. Set this to **Off** if you want the projector to go into **STANDBY** mode when the mains is connected. In this case, the projector will not start up until the **POWER** button is pressed on the control panel or the **ON** button is pressed on the remote control.

- **Scheduled on/off**

Access this submenu to create a weekly schedule for automatic on and off times:

1. Set a schedule:

- Use the **UP** and **DOWN** arrow buttons to highlight a row, then press **ENTER/OK** to enable edit mode.
- Within a row, navigate with the **LEFT** and **RIGHT** arrow buttons. Set values with the **UP** and **DOWN** arrow buttons.
- To exit edit mode, press **ENTER/OK**. Alternatively, press **EXIT** if you don't want the changes to take effect. Move to another row using the **UP** and **DOWN** arrow buttons.

2. To enable the schedule, set Schedule to **On**

- **Instant Startup**

When **ON** only the Laser will be turned off when the Power off command is given. A subsequent Power On will turn on the laser giving an apparent very fast power on.

- **Standby Period**

Used with Instant Startup. If Instant Startup in **ON** and the projector is powered down then the projector will go to Standby after the selected "Standby Period" 30 minutes, 60 minutes, 90 minutes.

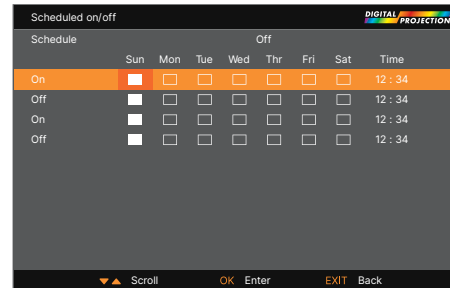

Notes

Clock adjust

Use this menu to set date (in **yyyy:MM:dd** format), time (in **HH:mm** format) and time zone. The date and time set here will affect any schedule created within the **Power On/Off** menu.

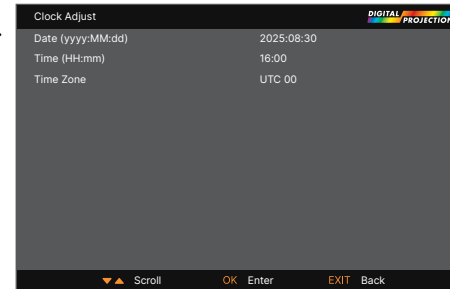

PIC MUTE setting

PIC MUTE allows the projected image to be hidden without turning the projector off.

- **PIC MUTE**

Choose from **Laser** and **DMD Blanking**. Select PIC MUTE to turn the laser off when the PIC MUTE is activated. Select DMD Blanking to project a black image when PIC MUTE is activated.

- **Fade In Timer**

Fade out timer is available when PIC MUTE is set to Laser. Choose from **Off, 1s, 2s, 3s, 4s** and **5s**. Select Off to start projecting the image as soon as PIC MUTE is deactivated. Select a time to fade the image in when PIC MUTE is deactivated.

- **Fade Out Timer**

Fade in timer is available when PIC MUTE is set to Laser. Choose from **Off, 1s, 2s, 3s, 4s** and **5s**. Select Off to stop projecting the image as soon as PIC MUTE is activated. Select a time to fade the image out when PIC MUTE is activated.

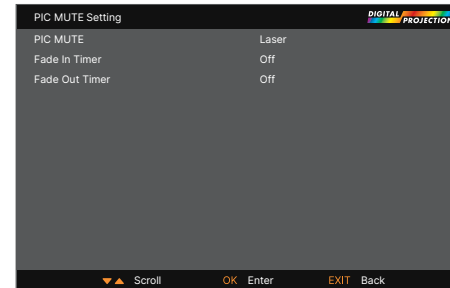

Notes

OSD settings

- **Language** sets the OSD language.
- **Menu Position** determines where the OSD should appear on the screen when activated.
- **Menu Transparency** sets OSD transparency between 0% (no transparency), 25%, 50% and 75%.
- **Time Out** determines how long the OSD should remain on screen if no buttons are pressed. Choose Always On to disable this feature.
- **Message Box** determines whether projector status messages should appear on the screen.
- **Menu Rotation** Choose from **Off**, **Clockwise** and **Counterclockwise**. Select a rotation option to rotate the OSD menu when the projector is displaying in portrait.

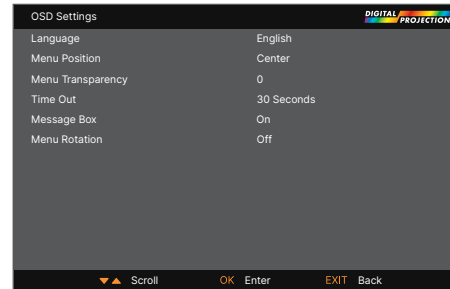

Memory

The current image settings can be saved as a preset, which you can recall later. The default settings can be recalled at any time as well.

Up to four custom presets can be stored for each input.

To recall a saved preset:

- Select **Recall Memory** and press **ENTER/OK**, then select a preset from **Preset A to Preset D**. Select **Default** to load factory default values.

To save a preset:

- Select **Save Settings** and press **ENTER/OK**, then choose from **Preset A, Preset B, Preset C and Preset D**.

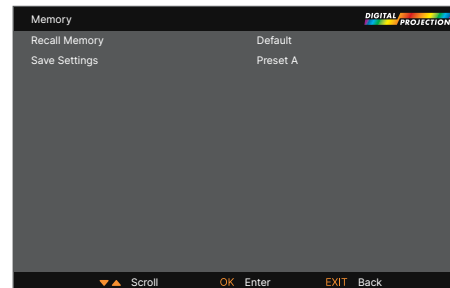

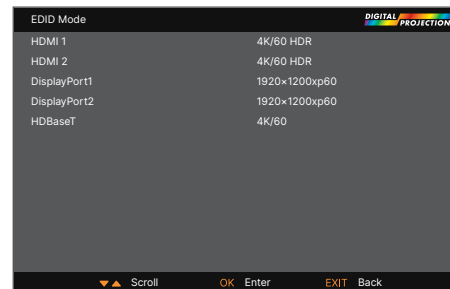

EDID Mode

Each signal input type is available in the menu. Select the appropriate frame rate and display resolution for each input.



Notes

-  Presets from one input cannot be applied to another input.
-  See "Appendix C: memory scheme and memory items" on page 119 for information about the parameters that can be saved in a memory preset.

Network menu

- **Network Setup**

Access this submenu to edit the network settings for the projector

- **Art-Net Setup**

Access this submenu to edit the Art-Net network settings for the projector

- **Art-Net Channel Setting**

Access this submenu to set the functions for each Art-Net channel

- **Art-Net Channel Status**

Access this submenu to view the status of each Art-Net channel

- **AMX**

Switch on or off

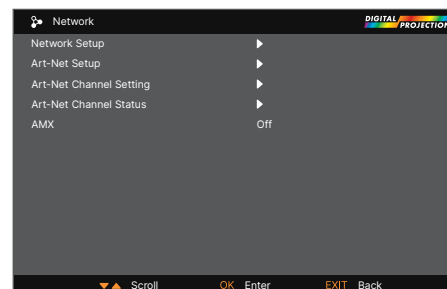

Network setup

- **DHCP, IP, Subnet Mask, Gateway, DNS**

Set DHCP to On if the IP address is to be assigned by a DHCP server, or Off if it is to be set here. If DHCP is On, it will not be possible to edit IP Address, Subnet Mask, Gateway or DNS.

If DHCP is set to Off, edit IP Address, Subnet Mask, Gateway and DNS as required.

- **MAC**

This field is read-only.

- **Apply**

Select to apply any changes to the network setup

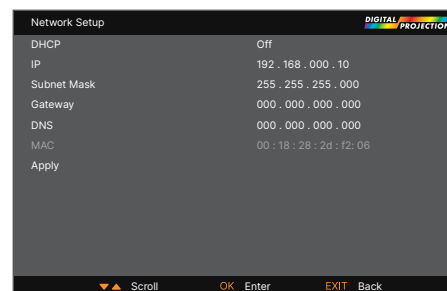

Notes

Art-Net setup

- **Art-Net Active**

Set to On to activate Art-Net DMX electronic light system control via the Art-Net port. Set the Net, Sub Net, Universe and Start Address for the network.

- **Apply**

Select to apply any changes to the Art-Net setup

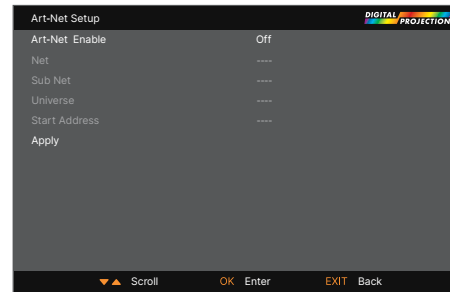

Art-Net Channel setting

- **Chanel 1-5**

Choose from None, Power, PIC Mute, Power Level, Input and Channel Control. Select the projector functions that are associated with each Art-Net channel.

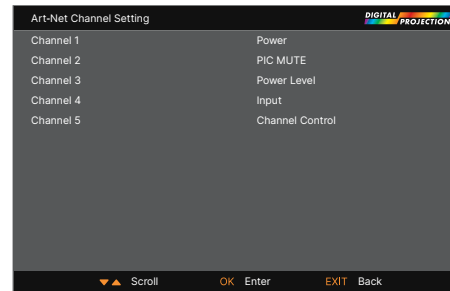

Art-Net Channel Status

- **Chanel 1-5**

Display current the control value for each channel

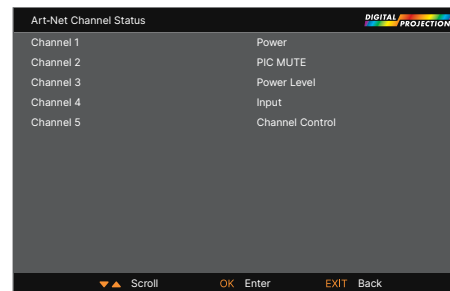

Notes

Information menu

This menu gives information about software and hardware configuration, input source and laser operating times. It also allows you to restore the factory default settings.

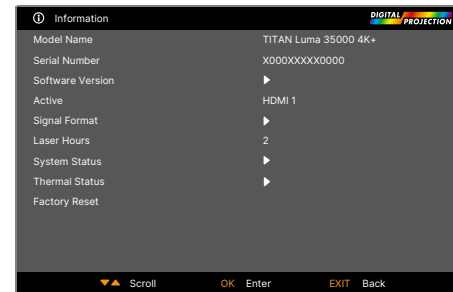

Software Version

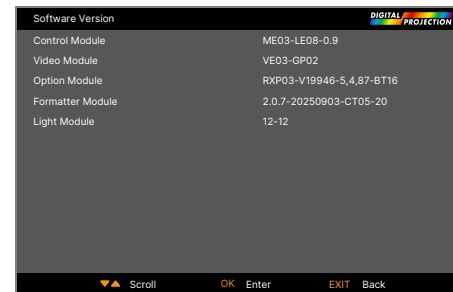

Signal format

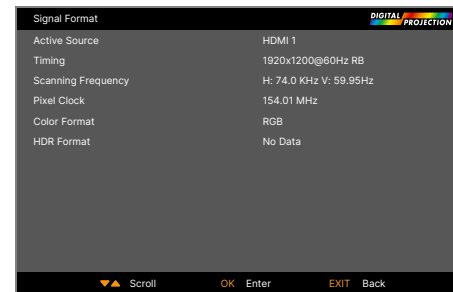

Notes

System status

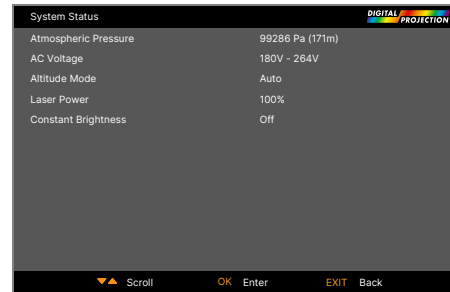

Thermal status

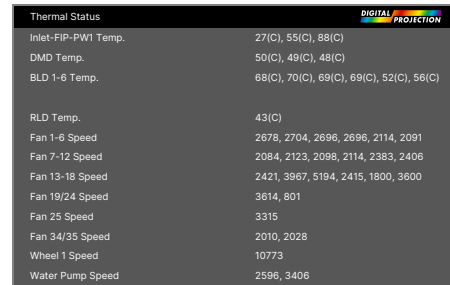

Factory reset

To restore the factory default settings:

1. Navigate to Factory Reset and press ENTER/OK.
2. When prompted, press ENTER/OK to confirm your choice, or press EXIT to cancel.

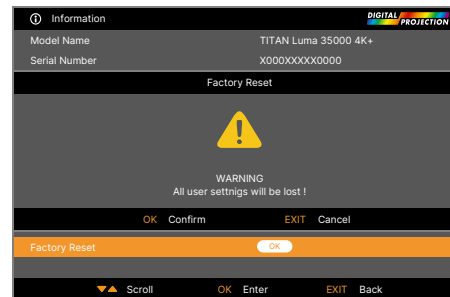

Notes



Factory reset does not reset the Network settings, or High Altitude mode.

Served web pages

The served web pages allow you to control the projector remotely via LAN.
The default IP address is 192.168.0.100.



- Projector Status
- Projector Control
- Network Setup
- Date/Time Setup
- Error Log
- DP OSD Function

Hot Key

PictMute OSD

Freeze

Projector Information	
Model	Titan Luma 35000 4K-UHD
Serial Number	C507XXXX01846
SW Version - Control Module	ME03-LE08-0.9
SW Version - Video Module	VE03-GP02
SW Version - Option Module	RXP03-V19946-5.4.87-BT16
SW Version - Formatter Module	2.0.7-20250903-CT05-20
SW Version - Light Module	12-12
Power Status	Power On
Input	HDMI 1
Laser Status	Power : Normal Runtime : 00325 H
Projection Mode	Auto-Front
High Altitude	Auto
Inlet Temperature	28 °C
DMD Temperature	50 / 49 / 48 °C
LD Temperature	68 °C
LD Temperature 2	70 °C
Diagnostic Status	Normal

LAN Information	
MAC address	00:18:23:52:EE:A0

Notes



- Projector Status
- Projector Control
- Network Setup
- Date/Time Setup
- Error Log
- DP OSD Function

- Hot Key
- PictMute
 - OSD
 - Freeze

State Control

Power

Input Selection

Lens Control

Zoom In Focus In Shift

Zoom OUT Focus OUT

Notes



- Projector Status
- Projector Control
- Network Setup
- Date/Time Setup
- Error Log
- DP OSD Function

Hot Key
PictMute OSD
Freeze

NetWork

DHCP: On Off

IP Address: 192 . 168 . 0 . 100

Subnet Mask: 255 . 255 . 255 . 0

Gateway: 192 . 168 . 0 . 1

DNS Server: 192 . 168 . 0 . 1

Save Settings

AMX: Off On

CAUTION: Incorrect settings may cause the projector to lose network connectivity. Please close webpage and reload when you settings.

Crestron Mode Fusion On Premises ▼

(After Mode Change, please "Apply" first !)

IP Address: 192 . 168 . 0 . 2

IP ID: (1 - 253) 4

Room ID:

(Up to 32 characters / VC4 must match Room ID Setting)

FITC URL https://

https://(up to 200 characters)

FITC URL Port: 443

https: 443

Use TLS: On Off

Non Secure Port: 41794

(40000 - 50000)

Secure Port: 41796

(40000 - 50000)

Notes

Enable Log In: Enable Disable

User Name:
(Up to 20 characters)

Password:
(Up to 16 characters)

Certificate On Off

Certificate Type Off

Upload Certificate 沒有選擇檔案

CAUTION: Incorrect settings will break the Crestron connection.

Auto Discovery

Auto Discovery On Off

Notes



- Projector Status
- Projector Control
- Network Setup
- Date/Time Setup
- Error Log
- DP OSD Function

Hot Key

Time Zone:

Time Zone:

Select Local time zone, Current zone is UTC (08:00)

Time:

Date: e.g.2000.01.01

Clock: e.g.23:59

Current time is set to : 2025.9.22 ; 9:32

Notes



- Projector Status
- Projector Control
- Network Setup
- Date/Time Setup
- Error Log
- DP OSD Function

Hot Key

- PictMute OSD
- Freeze

Projector Error Log

ErrLog:1 / Current PowerOn times:16

No	Code	PwrOn RunTime TotalTime Pwr	T(Ti,Tcr,Tcg,Tcb Tf,pw1)	L(Tb/Tr)	FANs...
1	1141	15 116 2192 100	32, 48, 47, 46 53, 85	63 67 66 65 48 52 38	F1=3780,F2=3780,F3=3766,F4=3773 F5=3145,F6=3165,F7=3165,F8=3155 F9=3160,F10=3171,F11=3485,F12=4083 F13=4246,F14=5791,F15=7943,F16=4278 F17=3057,F18=4169,F19=4156,F24=1296 F25=4232,F34=3947,F35=3971 Pump1=2592,Pump2=3400
ErrLensSwitchOpen					

Page 1 Page 2 Page 3 Page 4 Page 5



- Projector Status
- Projector Control
- Network Setup
- Date/Time Setup
- Error Log
- DP OSD Function

Hot Key

- PictMute OSD
- Freeze

Page 1 Page 2 Page 3

Input

- Input HDMI 1 ▾
- Backup Input Setting Off ▾
- Backup Mode HDMI ▾
- Backup Input Select
- HDMI Equalizer - [Slider] + 0
- Resync Resync

Test Pattern



Notes

Lens

- Lens Lock
- Lens Type_4K[®]
- Center Lens
- LensMemory

Image

- Dynamic Black
- Light Off Timer
- Smooth Picture
- Gamma
- HDR
- Brightness
- Contrast
- Saturation
- Hue
- Sharpness
- Noise Reduction
- Freeze

color

- Color Space
- Color Mode
- Color Max
- Manual Color Matching
- Auto Test Pattern
- Red**
 - Hue
 - Saturation
 - Gain
- Green**
 - Hue
 - Saturation
 - Gain
- Blue**
 - Hue
 - Saturation
 - Gain
- Yellow**
 - Hue
 - Saturation
 - Gain

Notes

Magenta
 Hue - + 500
 Saturation - + 500
 Gain - + 500

Cyan
 Hue - + 500
 Saturation - + 500
 Gain - + 500

White Balance
 Red - + 500
 Green - + 500
 Blue - + 500

Manual Color Matching Reset

- Color Temperature 6500K
- Gains and Lifts
 - Red Lift - + 100
 - Green Lift - + 100
 - Blue Lift - + 100
 - Red Gain - + 100
 - Green Gain - + 100
 - Blue Gain - + 100

Gains and Lifts Reset

Page 1 Page 2 Page 3

DIGITAL PROJECTION

Projector Status
 Projector Control
 Network Setup
 Date/Time Setup
 Error Log
 DP OSD Function

Hot Key
 PictMute OSD
 Freeze

Geometry

- Aspect Ratio 16:9
- Digital Zoom
 - Digital Zoom - + 0%
 - Digital Pan - + 0
 - Digital Scan - + 0
- Digital Zoom Reset
- Overscan Off
- Blanking
 - Top - + 0
 - Bottom - + 0
 - Left - + 0
 - Right - + 0
- Blanking Reset
- Warping Mode Off
- Keystone
 - H Keystone - + 0
 - V Keystone - + 0
 - Rotation - + 0
 - Lens Throw Ratio - + 1.8

Edge Blend

- Edge Blend Mode
- Align Pattern
- Blend Start
 - Top
 - Bottom
 - Left
 - Right
- Blend Width
 - Top
 - Bottom
 - Left
 - Right
- Black Level Uplift
 - Select Area
 - Top Left X
 - Top Left Y
 - Top Right X
 - Top Right Y
 - Bottom Left X
 - Bottom Left Y
 - Bottom Right X
 - Bottom Right Y
- Color Adjustment
 - All
 - Red
 - Green
 - Blue
 - Reset
- Uniformity
 - Mode
 - Location X
 - Location Y
 - Red Gain
 - Green Gain
 - Blue Gain
 -

3D

- 3D Format
- Eye Swap
- Dark Time
- Sync Offset
- Sync Reference

Notes

Notes

Laser

- Power Mode: Normal
- Power Level: 100
- Constant Brightness: Off
- Brightness_Sync Mode: Off
 - Brightness Sync Group: 0 1 2
 - Brightness Sync Interval: 5
 - Brightness Sync Status: SLAVE_OFF_LINE

Page 1 Page 2 Page 3



Setup

- Orientation: Auto-Front
- High Altitude: Auto
- Standby Mode: ECO
- Screen Setting
 - Screen Format: 16:9
 - Screen Position: 0
- ColorMax Setting

Measured Data

Red	X:0.060	Y:0.338
Green	X:0.289	Y:0.682
Blue	X:0.140	Y:0.42
White	X:0.304	Y:0.334

Measured Data Save Measured Data Reset

Target Data - User 1

Red	X:0.640	Y:0.330
Green	X:0.300	Y:0.600
Blue	X:0.150	Y:0.60
Yellow	X:0.419	Y:0.505
Cyan	X:0.225	Y:0.329
Magenta	X:0.321	Y:0.154
White	X:0.299	Y:0.322

Target Data - User 1 Save Target Data - User 1 Reset

Target Data - User 2

Red	X:0.640	Y:0.330
Green	X:0.300	Y:0.600
Blue	X:0.150	Y:0.60
Yellow	X:0.419	Y:0.505
Cyan	X:0.225	Y:0.329
Magenta	X:0.321	Y:0.154
White	X:0.299	Y:0.322

Target Data - User 2 Save Target Data - User 2 Reset

Page 1 Page 2 Page 3

- Projector Status
 - Projector Control
 - Network Setup
 - Date/Time Setup
 - Error Log
 - DP OSD Function
- Hot Key
- PictMute OSD
 - Freeze

• Power on/off Management

Auto Power Off ▼

Auto Power On ▼

Scheduled on/off off on

	Sun	Mon	Tue	Wed	Thu	Fri	Sat	Time(HH:MM)
On	<input type="checkbox"/>	<input type="checkbox"/>	<input type="checkbox"/>	<input type="checkbox"/>	<input type="checkbox"/>	<input type="checkbox"/>	<input type="checkbox"/>	00:00
Off	<input type="checkbox"/>	<input type="checkbox"/>	<input type="checkbox"/>	<input type="checkbox"/>	<input type="checkbox"/>	<input type="checkbox"/>	<input type="checkbox"/>	00:00
On	<input type="checkbox"/>	<input type="checkbox"/>	<input type="checkbox"/>	<input type="checkbox"/>	<input type="checkbox"/>	<input type="checkbox"/>	<input type="checkbox"/>	00:00
Off	<input type="checkbox"/>	<input type="checkbox"/>	<input type="checkbox"/>	<input type="checkbox"/>	<input type="checkbox"/>	<input type="checkbox"/>	<input type="checkbox"/>	00:00

Instant Startup ▼

Standby Period ▼

• Startup Logo ▼

• Blank Screen ▼

• Auto Source ▼

• PIC MUTE Setting

PIC MUTE ▼

Fade In Timer ▼

Fade Out Timer ▼

• Trigger ▼

• Infrared Remote ▼

• IR Code

• OSD Setting

Language ▼

Menu Position ▼

Menu Transparency ▼

Time Out ▼

Message Box ▼

Menu Rotation ▼

• Trigger ▼

• Infrared Remote ▼

• IR Code

• OSD Setting

Language ▼

Menu Position ▼

Menu Transparency ▼

Time Out ▼

Message Box ▼

Menu Rotation ▼

• Memory

Recall Memory ▼

Save Settings ▼

• EDID Mode

HDMI1 ▼

HDMI2 ▼

DisplayPort1 ▼

DisplayPort2 ▼

HDBaseT ▼

• Smear Reduction ▼

• Output Frame Rate ▼

• Image Latency ▼

Notes

Information

- Model Name Titan Luma 35000 4K-UHD
- Serial Number C507XXXX01846
- Software Version ME03-LE08-0.9
- Control Module VE03-GP02
- Video Module RXP03-V19946-5.4.87-BT16
- Option Module Formatter Module 2.0.7-20250903-CT05-20
- Light Module 12-12
- Active HDMI 1
- Signal Format HDMI 1
- Active Source 1920x1200@59.94Hz
- Timing 74.0 KHz 59.94 Hz
- Scanning Frequency 153.96 MHz
- Pixel Clock No Data
- HDR Format 325 HRS
- Laser Hours
- System Status
- Atmospheric Pressure 99248 Pa (174 m)
- AC Voltage 200V ~ 240V
- Altitude Mode Auto
- Laser Power 100%
- Custom Brightness Off
- Thermal Status
- Inlet-FIP-PW1 Temp. 31(C), 50(C), 80(C)
- DMD Temp. 46(C), 45(C), 44(C)
- BLD 1-6 Temp. 61(C), 64(C), 63(C), 62(C), 44(C), 47(C)
- RLD Temp. 38(C)
- Fan 1-6 Speed 3568, 3555, 3574, 3548, 2974, 2969
- Fan 7-12 Speed 2965, 2960, 2938, 2960, 3249, 3752
- Fan 13-18 Speed 3908, 5438, 7405, 3924, 2804, 4053
- Fan 19/24 Speed 4062, 1201
- Fan 25 Speed 4053
- Fan 34/35 Speed 3568, 3548
- Wheel 1 Speed 10802
- Water Pump Speed 2586, 3412
- Factory Reset [Factory Reset](#)

Page 1 Page 2 Page 3

Notes

DIGITAL **PROJECTION**

A brand of  **DELTA**

TITAN Luma 35000 4K+ & 37000 WU

High Brightness Digital Video Projector

REFERENCE GUIDE



Choosing a lens

A number of lenses are available. Which lens you choose depends on the screen size, image aspect ratio, throw distance and light output. The following table shows all available lenses in order of their throw ratios:

Lens	Focus Range	Lens Shift	Lens Extension	Part No
0.37:1 (Right Angled)	1.6m - 4.9m	Vert: 0.6 (U) 0.6 (D) frame, Hor: 0.31 (L) 0.31 (R) frame	215mm	120-510
0.65-0.85:1 (Right Angled)	2.8m - 8.4m	Vert: 0.51 (U) 0.51 (D) frame, Hor: 0.24 (L) 0.24 (R) frame	281mm	120-511
0.67:1 fixed HB	1.1m - 3.2m	Vert: 0.108 (U) 0.108 (D) frame, Hor: 0.044 (L) 0.044 (R) frame	141mm	105-607
0.8-1.16:1 (Includes support bracket)	1.7m - 11m	Vert: 0.4 (U) 0.4 (D) frame, Hor: 0.19 (L) 0.19 (R) frame	235	120-827
1.12:1 (short) fixed HB	3m - 15m	Vert: 0.567 (U) 0.567 (D) frame, Hor: 0.273 (L) 0.273 (R) frame	205mm	105-608
1.16 - 1.49:1 zoom HB	3m - 15m	Vert: 0.408 (U) 0.408 (D) frame, Hor: 0.188 (L) 0.188 (R) frame	162.5mm	109-236
1.39 - 1.87:1 zoom HB	4m - 24m	Vert: 0.567 (U) 0.45 (D) frame, Hor: 0.273 (L) 0.273 (R) frame	130.5mm	105-610
1.87 - 2.56:1 zoom HB	4m - 24m	Vert: 0.567 (U) 0.45 (D) frame, Hor: 0.273 (L) 0.273 (R) frame	95.3 mm	105-611
2.56 - 4.16:1 zoom HB	9.1m - 45m	Vert: 0.567 (U) 0.45 (D) frame, Hor: 0.273 (L) 0.273 (R) frame	88.7mm	105-612
4.16 - 6.96:1 zoom HB	12m - 80m	Vert: 0.567 (U) 0.45 (D) frame, Hor: 0.273 (L) 0.273 (R) frame	55mm	105-613
6.92 - 10.36:1 zoom HB	12m - 80m	Vert: 0.567 (U) 0.45 (D) frame, Hor: 0.273 (L) 0.273 (R) frame	105mm	109-235

To choose a lens, calculate the throw ratio required. Allow a tolerance of +/- 3% in the throw ratio calculation.

Notes

Basic calculation

Identify the required lens by calculating the *throw ratio*

A throw ratio is the ratio of the throw distance ② to the screen width ①

Throw Ratio = Throw Distance / Screen Width

1. Use the formula above to obtain the required throw ratio.
2. Allow a tolerance of +/- 3% in the throw ratio calculation and match the throw ratio with a lens from the table below:

Throw Ratios	Focus Range
0.37:1 (Right Angled)	1.6m - 4.9m
0.65-0.85:1 (Right Angled)	2.8m - 8.4m
0.67:1 fixed HB	1.1m - 3.2m
0.8-1.16:1 (Includes support bracket)	1.7m - 11m
1.12:1 (short) fixed HB	3m - 15m
1.16 - 1.49:1 zoom HB	3m - 15m
1.39 - 1.87:1 zoom HB	4m - 24m
1.87 - 2.56:1 zoom HB	4m - 24m
2.56 - 4.16:1 zoom HB	9.1m - 45m
4.16 - 6.96:1 zoom HB	12m - 80m
6.92 - 10.36:1 zoom HB	12m - 80m

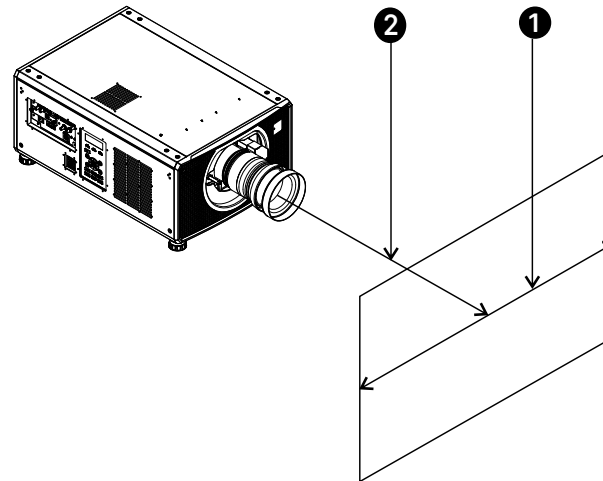

Notes



The basic calculation on this page does not take into consideration DMD™ and image size, which could affect the throw ratio.

See "Full lens calculation" on page 101 for a more complex and realistic calculation.



When calculating the throw ratio, be sure to use identical measurement units for both the throw distance and the screen width.



See "Choosing a lens" on page 98 for information about individual lens part numbers.

Ensure the required throw distance is within the range covered by the lens.

Basic calculation example

- Calculate the throw ratio using the formula.
Your screen is **4.5m** wide and you wish to place the projector approximately **11m** from the screen. The throw ratio will then be $11 \div 4.5 = 2.44$
- Match the result with the lens table.
The lens matching a throw ratio of 2.44 is the **1.87 - 2.56:1 Standard Zoom lens**.
- Check whether the lens covers the required throw distance.**
The focus range quoted for the 1.87 - 2.56:1 Standard Zoom lens is **4 - 24m**. The required distance of 11m is within the range.

INFORMATION YOU NEED FOR THIS CALCULATION

The throw ratio formula:

Throw Ratio = Throw Distance / Screen Width

Allow a tolerance of +/- 3% in the throw ratio calculation.

The lens table:

Throw Ratios	Focus Range
0.37:1 (Right Angled)	1.6m - 4.9m
0.65-0.85:1 (Right Angled)	2.8m - 8.4m
0.67:1 fixed HB	1.1m - 3.2m
0.8-1.16:1 (Includes support bracket)	1.7m - 11m
1.12:1 (short) fixed HB	3m - 15m
1.16 - 1.49:1 zoom HB	3m - 15m
1.39 - 1.87:1 zoom HB	4m - 24m
1.87 - 2.56:1 zoom HB	4m - 24m
2.56 - 4.16:1 zoom HB	9.1m - 45m
4.16 - 6.96:1 zoom HB	12m - 80m
6.92 - 10.36:1 zoom HB	12m - 80m

Notes



The basic calculation on this page does not take into consideration DMD™ and image size, which could affect the throw ratio.

See "Full lens calculation" on page 101 for a more complex and realistic calculation.



See "Choosing a lens" on page 98 for information about individual lens part numbers.

Full lens calculation

Introducing TRC

The choice of lens will affect the image size and will address discrepancies between the DMD™ resolution and the source.

When an image fills the height of the DMD™ but not the width, it uses less than 100% of the DMD™ surface. A lens chosen using the basic formula may produce an image that is considerably smaller than the actual screen.

To compensate for loss of screen space in such situations, you need to increase the throw ratio using a **Throw Ratio Correction (TRC)**.

Example

Fig. 1 illustrates a 4:3 image within a 16:9 display

When a 16:9 projector is used for a 4:3 image, the image does not fill the width of the DMD™, creating a **pillarboxing** effect - blank spaces to the left and right.

Fig. 2 shows the same image projected on a 4:3 screen using a standard lens (chosen with the basic calculation).

The DMD™ accurately fills the width of the screen; however, the pillarboxing is now part of the projected image and is transferred to the screen.

The DMD™ does not fill the height of the screen, which has caused **letterboxing** - further blank spaces at the top and bottom of the screen.

The image is now surrounded by blank space, which can be removed if the throw ratio is increased.

Fig. 3 shows the image projected on the same screen with a lens chosen using TRC. The increased throw ratio has allowed the 4:3 image to fill the 4:3 screen seamlessly



Fig 1

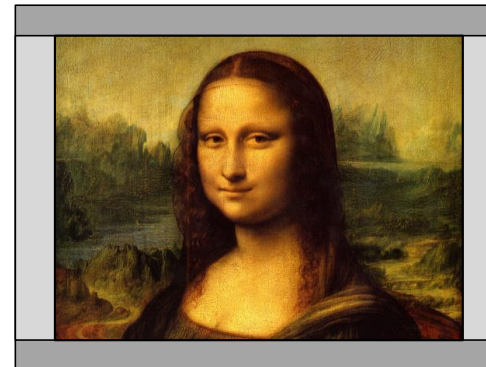

Fig 2



Fig 3

Notes



TRC can only be applied if greater than 1. If TRC is 1 or less, disregard it and calculate the throw ratio using the basic formula..

Calculating Throw Ratio Correction (TRC).

To calculate TRC, use the following formula:

$$TRC = 1.6(DMD^{TH} \text{ Aspect Ratio}) / \text{Source Aspect Ratio}$$

TRC table

Alternatively, you can save time by referencing the following table, which shows the TRC value for some popular image formats:

2.35:1 (Scope)	1920 x 817 pixels	TRC < 1, not used
1.85:1 (Flat)	1920 x 1037 pixels	TRC < 1, not used
1.78:1 (16:9)	1920 x 1080 pixels	TRC < 1, not used
1.6:1 (16:10)	1920 x 1200 pixels	TRC < 1, not used (native aspect ratio)
1.33:1 (4:3)	1596 x 1200 pixels	TRC = 1.2
1.25:1 (5:4)	1500 x 1200 pixels	TRC = 1.28

Calculating the throw ratio with TRC

1. For TRC > 1, amend the basic throw ratio formula as follows:

$$\text{Throw Ratio} = \text{Throw Distance} / \text{Screen Width} * TRC$$

Allow a tolerance of +/- 3% in the throw ratio calculation.

2. Once a throw ratio is established, identify the matching lens from the table:

Throw Ratios	Focus Range
0.37:1 (Right Angled)	1.6m - 4.9m
0.65-0.85:1 (Right Angled)	2.8m - 8.4m
0.67:1 fixed HB	1.1m - 3.2m
0.8-1.16:1 (Includes support bracket)	1.7m - 11m
1.12:1 (short) fixed HB	3m - 15m
1.16 - 1.49:1 zoom HB	3m - 15m
1.39 - 1.87:1 zoom HB	4m - 24m
1.87 - 2.56:1 zoom HB	4m - 24m
2.56 - 4.16:1 zoom HB	9.1m - 45m
4.16 - 6.96:1 zoom HB	12m - 80m
6.92 - 10.36:1 zoom HB	12m - 80m

3. Ensure the required throw distance is within the range of the matching lens

Notes



TRC can only be applied if greater than 1. If TRC is 1 or less, disregard it and calculate the throw ratio using the basic formula.

Full lens calculation example

Your screen is **4.5m** wide; you wish to place the projector approximately **11m** from the screen. The source is **4:3**.

1. Calculate TRC as follows:

$$TRC = 1.6 / 1.33 = 1.2.$$

2. Calculate the throw ratio:

$$\text{Throw ratio} = 11 / 4.5 \times 1.2 = \mathbf{2.04}$$

3. Allow a tolerance of +/- 3% in the throw ratio calculation and find a match in the lens table.

The table shows that the matching lens is **the 1.87 - 2.56:1 Standard Zoom lens**.

4. Check whether the lens covers the required throw distance.

The focus range quoted for the 1.87 - 2.56:1 Standard Zoom lens is **4m - 24m**. The required distance of 11 m is within the range.

INFORMATION YOU NEED FOR THIS CALCULATION

The TRC formula

$$TRC = DMD^{TH} \text{ Aspect Ratio} / \text{Source Aspect Ratio}$$

The TRC table (to use instead of the formula)

2.35:1 (Scope)	TRC < 1, not used
1.85:1 (Flat)	TRC < 1, not used
1.78:1 (16:9)	TRC < 1, not used
1.6:1 (16:10)	TRC < 1, not used (native aspect ratio)
1.33:1 (4:3)	TRC = 1.2
1.25:1 (5:4)	TRC = 1.28

The throw ratio formula

$$Throw Ratio = Throw Distance / Screen Width * TRC$$

Allow a tolerance of +/- 3% in the throw ratio calculation.

The lens table:

Throw Ratios	Focus Range
0.37:1 (Right Angled)	1.6m - 4.9m
0.65-0.85:1 (Right Angled)	2.8m - 8.4m
0.67:1 fixed HB	1.1m - 3.2m
0.8-1.16:1 (Includes support bracket)	1.7m - 11m
1.12:1 (short) fixed HB	3m - 15m
1.16 - 1.49:1 zoom HB	3m - 15m
1.39 - 1.87:1 zoom HB	4m - 24m
1.87 - 2.56:1 zoom HB	4m - 24m
2.56 - 4.16:1 zoom HB	9.1m - 45m
4.16 - 6.96:1 zoom HB	12m - 80m
6.92 - 10.36:1 zoom HB	12m - 80m

Notes

Screen requirements

Fitting the image to the display

If the source image supplied to the projector is smaller than the WUXGA resolution, the image will not fill the display. The following examples show how a number of common formats may be displayed, depending on your DMD™ resolution.

WUXGA images displayed full width

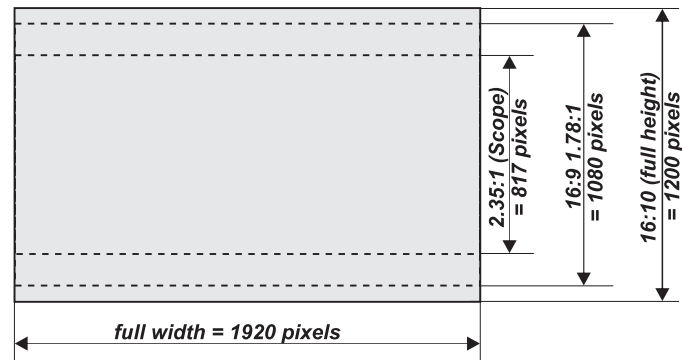

WUXGA images displayed with a height of 1200 pixels

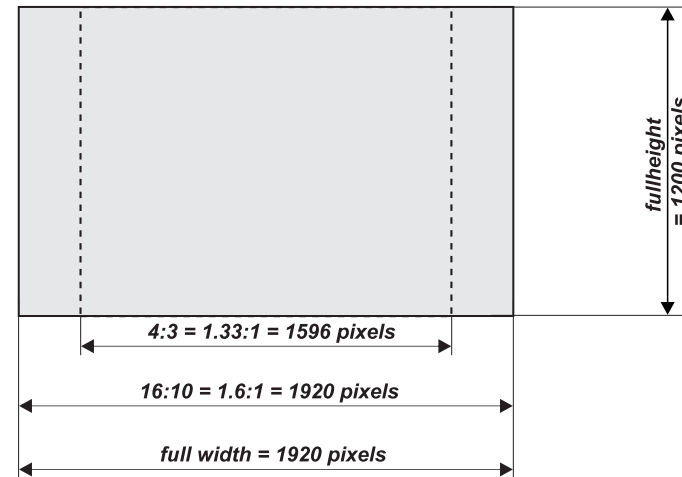

Notes

WUXGA images displayed full height

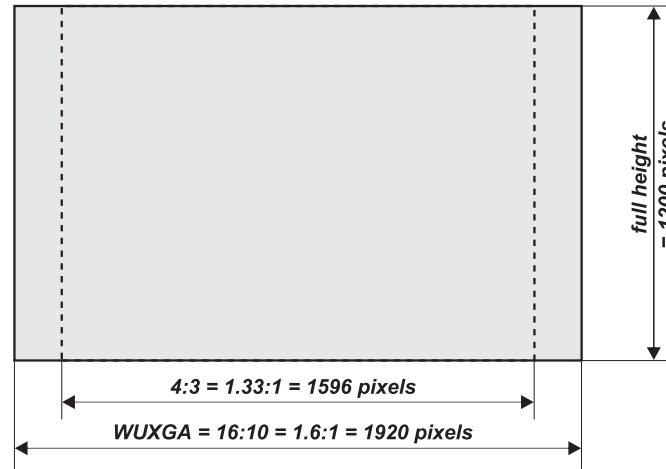

Notes

Diagonal screen sizes

Screen sizes are sometimes specified by their diagonal size (D). When dealing with large screens and projection distances at different aspect ratios, it is more convenient to measure screen width (W) and height (H).

The example calculations below show how to convert diagonal sizes into width and height, at various aspect ratios.

2.35:1 (Scope)

$W = D \times 0.92$ $H = D \times 0.39$

1.85:1

$W = D \times 0.88$ $H = D \times 0.47$

16:9 = 1.78:1

$W = D \times 0.87$ $H = D \times 0.49$

16:10 = 1.6:1 (native aspect ratio for WUXGA projectors)

$W = D \times 0.85$ $H = D \times 0.53$

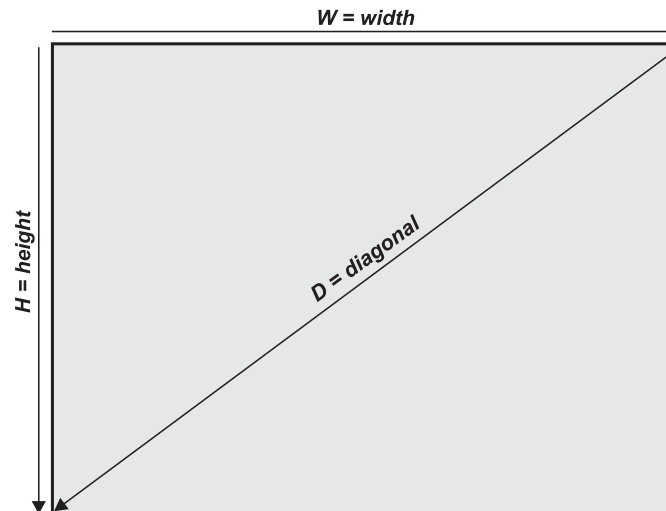

Positioning the image

The normal position for the projector is at the centre of the screen. However, you can set the projector above or below the centre, or to one side, and adjust the image using the **Lens shift** feature (known as **rising and falling front**) to maintain a geometrically correct image.

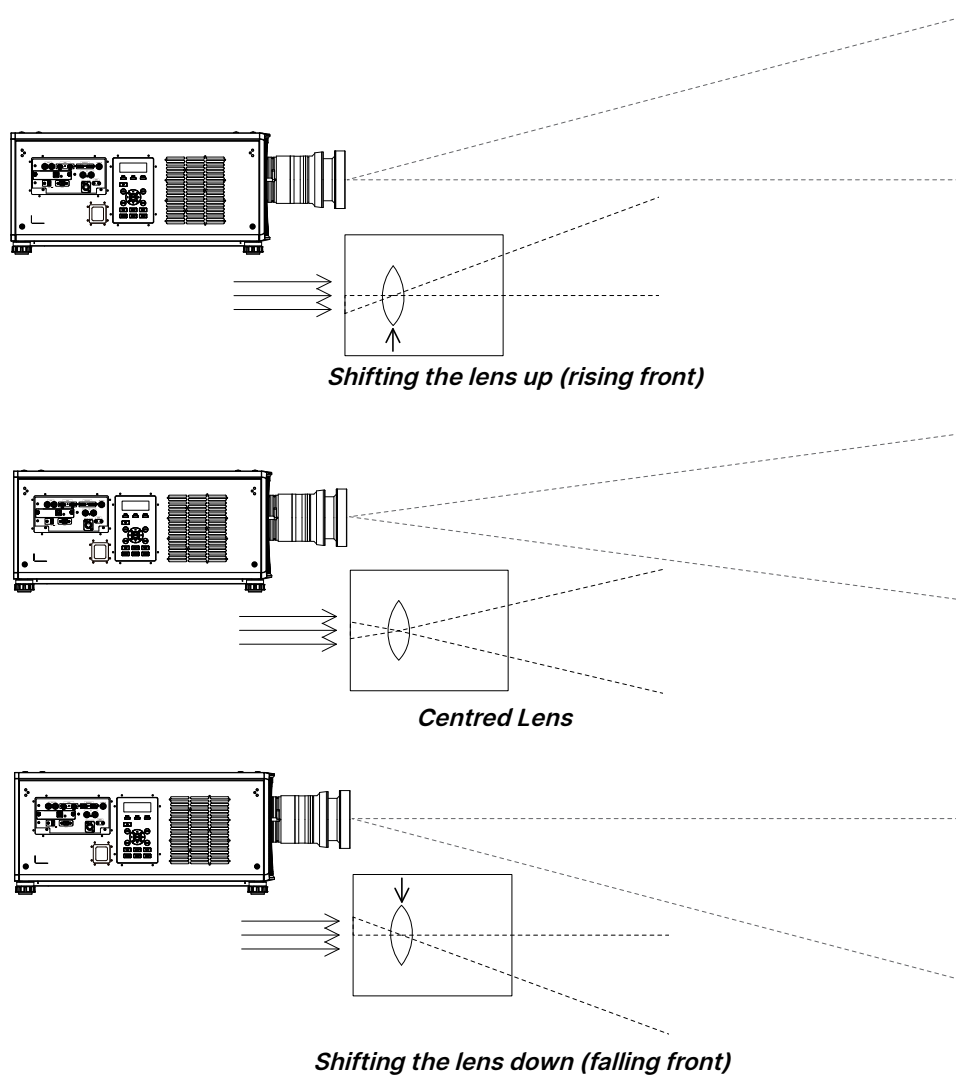

Notes



See "Lens control" on page 48 for more information on shifting the lens.



Whenever possible, position the projector so that the lens is centered for the highest quality image.

Any single adjustment outside the ranges specified on the following page may result in an unacceptable level of distortion, particularly at the corners of the image, due to the image passing through the periphery of the lens optics.

If the lens is to be shifted in two directions combined, the maximum range without distortion will be somewhat less, as can be seen in the illustrations.

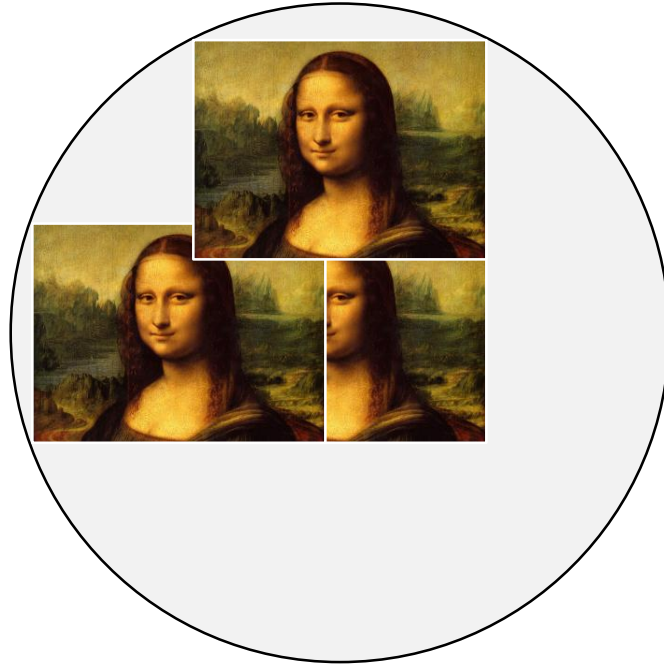

Full horizontal or vertical shift

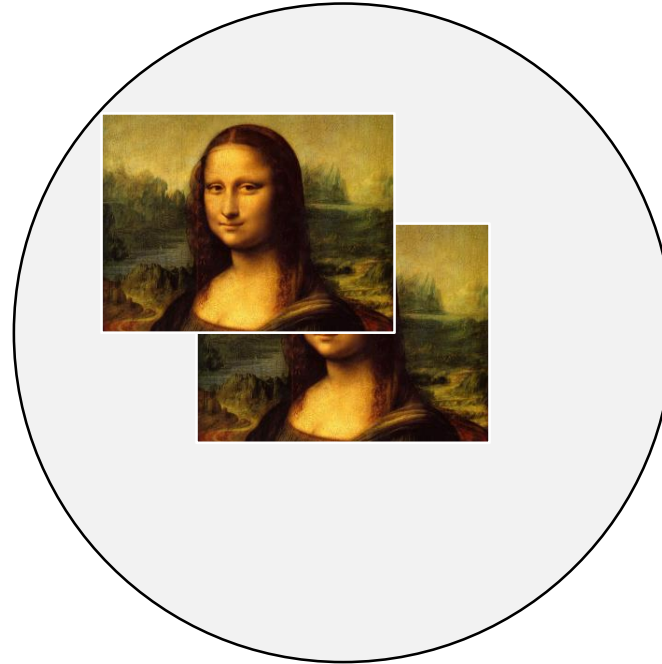

Combined shift is reduced

Notes



See "Lens control" on page 48 for more information on shifting the lens.

Aspect ratios explained

The appearance of a projected image on the screen depends on a combination of the following:

- The display resolution is **WUXGA** with a 1920 x 1200 resolution, corresponding to an aspect ratio of 16:10
- The aspect ratio of the input signal: usually **4:3**, **16:9** or **16:10**
- The value of the **Aspect Ratio** setting of the projector:
 - **16:9**, **4:3**, **16:10** and **5:4** stretch the image to the selected aspect ratio. **16:9** leaves black bars at the top and bottom of the screen (letterboxing effect); **4:3** and **5:4** leave black bars at the sides of the screen (pillarboxing).
 - **TheaterScope** is a special setting used in combination with an anamorphic lens, an optional accessory. It removes letterboxing from a 2.35:1 source packed into a 16:9 frame.
 - **Source** shows the image with its original aspect ratio, if this does not match the native aspect ratio of the DMD either fit the full width or height of the display.

Aspect ratios examples

1. Unused screen areas

Source: 4:3

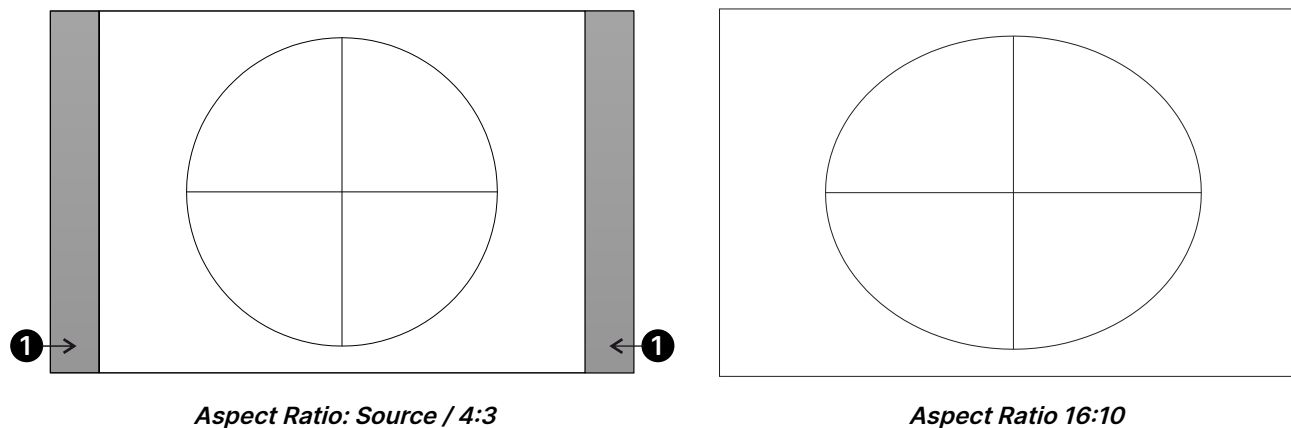

Notes

Source: 16:9

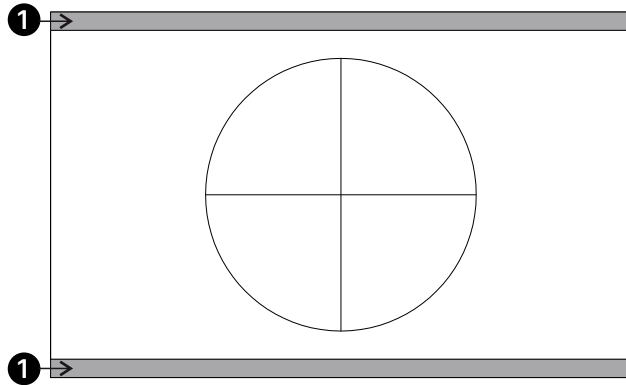

Aspect Ratio: Source / 4:3

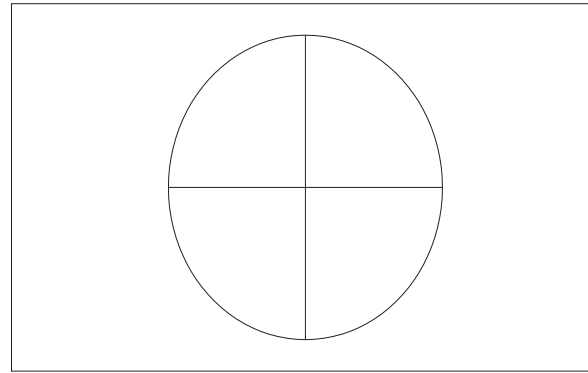

Aspect Ratio 16:10

Source: 16:10 (native)

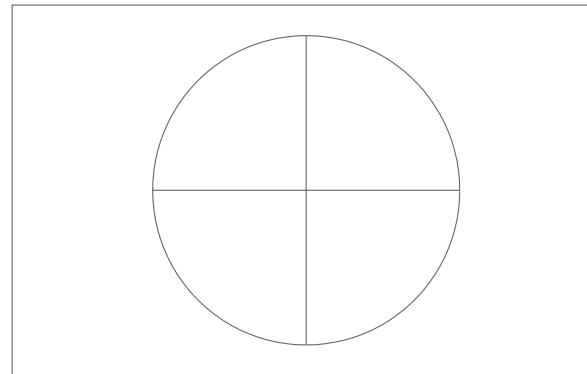

Aspect Ratio: Source / 16:10

Notes

Aspect ratio example: TheatreScope

The TheaterScope setting is used in combination with an anamorphic lens to restore 2.35:1 images packed into a 16:9 frame. Such images are projected with black lines at the top and bottom of the 16:9 screen to make up for the difference in aspect ratios.

Without an anamorphic lens and without the TheaterScope setting applied, a 16:9 source containing a 2.35:1 image looks like this

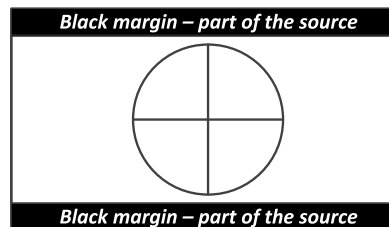

If we change the setting to TheaterScope, the black lines will disappear but the image will stretch vertically to reach the top and bottom of the DMD™:

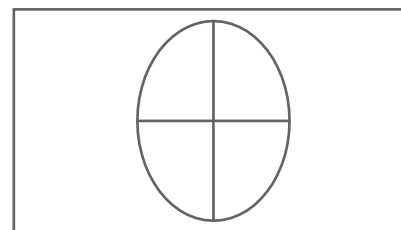

An anamorphic lens will stretch the image horizontally, restoring the original 2.35 ratio:

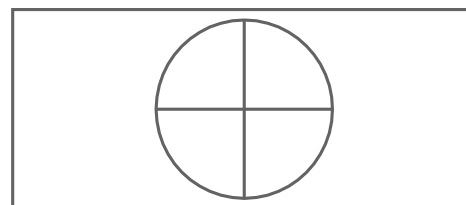

Notes



Appendix A: supported signal input modes

Notes

2D formats

Signal Format	Resolution	Frame Rate (Hz)	DisplayPort	HDMI / HDBaseT			
				RGB	YUV 8-bit	YUV 10-bit	YUV 12-bit
PC	640 x 480	59.94	○	○			
	640 x 480	74.99	○	○			
	640 x 480	85	○	○			
	800 x 600	60.32	○	○			
	800 x 600	75	○	○			
	800 x 600	85.06	○	○			
	848 x 480	47.95	○	○			
	848 x 480	59.94	○	○			
	1024 x 768	60	○	○			
	1024 x 768	75	○	○			
	1024 x 768	85	○	○			
	1280 x 720	47.95	○	○			
	1280 x 768	60	○	○			
	1280 x 800	60	○	○			
	1280 x 960	60	○	○			
	1280 x 1024	60.02	○	○			
	1280 x 1024	75.02	○	○			
	1280 x 1024	85.02	○	○			
	1366 x 768	60	○	○			
	1440 x 900	60	○	○			
	1400 x 1050	60	○	○			
	1600 x 1200	60	○	○			
	1680 x 1050	59.94	○	○			
	1920 x 1080	47.95	○	○			
1920 x 1200 RB	50	○	○				
1920 x 1200 RB	60	○	○				

Signal Format	Resolution	Frame Rate (Hz)	DisplayPort	HDMI / HDBaseT				Notes
				RGB	YUV 8-bit	YUV 10-bit	YUV 12-bit	
PC	2048×1152 RB	60	○					
	2560×1600 RB	60	○					
	3840×2400 RB	24	○	○				
	3840×2400 RB	25	○	○				
	3840×2400 RB	30	○	○				
	3840×2400 RB	50	○	○				
	3840×2400 RB	60	○	○				
Apple Mac	640 x 480	66.59	○	○				
	832 x 624	74.54	○	○				
EDTV	480p	59.94	○	○	○	○	○	
	576p	50	○	○	○	○	○	
HDTV	1080i	50	○	○	○	○	○	
	1080i	59.94	○	○	○	○	○	
	1080i	60	○	○	○	○	○	
	720p	50	○	○	○	○	○	
	720p	59.94	○	○	○	○	○	
	720p	60	○	○	○	○	○	
	1080p	23.98	○	○	○	○	○	
	1080p	24	○	○	○	○	○	
	1080p	25	○	○	○	○	○	
	1080p	29.97	○	○	○	○	○	
	1080p	30	○	○	○	○	○	
	1080p	50	○	○	○	○	○	
	1080p	59.94	○	○	○	○	○	
	1080p	60	○	○	○	○	○	
	2K (2048×1080)	24	○	○	○	○	○	
	2K (2048×1080)	25	○	○	○	○	○	
	2K (2048×1080)	30	○	○	○	○	○	
	2K (2048×1080)	50	○	○	○	○	○	
2K (2048×1080)	60	○	○	○	○	○		

Signal Format	Resolution	Frame Rate (Hz)	DisplayPort	HDMI / HDBaseT				Notes
				RGB	YUV 8-bit	YUV 10-bit	YUV 12-bit	
HDTV	4K-UHD	24	○	○	○	○*1	○*1	<p> *1: HDBaseT supports 4K 24/25/30Hz 4:2:2 only</p> <p> *2: HDBaseT supports 4K 50/60Hz 4:2:0 only</p> <p> *3: HDMI 1,2 support up to 4:2:2, HDBaseT does not support</p>
	4K-UHD	25	○	○	○	○*1	○*1	
	4K-UHD	30	○	○	○	○*1	○*1	
	4K-UHD	50	○	○	○*2	○*3	○*3	
	4K-UHD	60	○	○	○*2	○*3	○*3	

12G-SDI (SDI Format)

Timing	SDI Link mode	Signal Standards	Color Encode	Sampling Structure	Bit Depth
1080i59	HD	SMPTE 292M 1.5Gbps HD	YCbCr	4:2:2	10
1080i60	HD	SMPTE 292M 1.5Gbps HD	YCbCr	4:2:2	10
1080P30	HD	SMPTE 292M 1.5Gbps HD	YCbCr	4:2:2	10
1080P25	HD	SMPTE 292M 1.5Gbps HD	YCbCr	4:2:2	10
1080i50	HD	SMPTE 292M 1.5Gbps HD	YCbCr	4:2:2	10
1080P24	HD	SMPTE 292M 1.5Gbps HD	YCbCr	4:2:2	10
720P60	HD	SMPTE 292M 1.5Gbps HD	YCbCr	4:2:2	10
720P50	HD	SMPTE 292M 1.5Gbps HD	YCbCr	4:2:2	10
1080P50	3G Level A	SMPTE 424M 3Gbps	YCbCr	4:2:2	10
1080P59	3G Level A	SMPTE 424M 3Gbps	YCbCr	4:2:2	10
1080P60	3G Level A	SMPTE 424M 3Gbps	YCbCr	4:2:2	10
2160p24 (3840×2160)	6G (Single Link)	SMPTE 2081 6Gbps	YCbCr	4:2:2 / 4:2:0	10
2160p25 (3840×2160)	6G (Single Link)	SMPTE 2081 6Gbps	YCbCr	4:2:2 / 4:2:0	10
2160p30 (3840×2160)	6G (Single Link)	SMPTE 2081 6Gbps	YCbCr	4:2:2 / 4:2:0	10
2160p24 (4096×2160)	6G (Single Link)	SMPTE 2081 6Gbps	YCbCr	4:2:2	10
2160p25 (4096×2160)	6G (Single Link)	SMPTE 2081 6Gbps	YCbCr	4:2:2	10
2160p30 (4096×2160)	6G (Single Link)	SMPTE 2081 6Gbps	YCbCr	4:2:2	10
2160p24 (3840×2160)	12G (Single Link - 2SI)	SMPTE 2082 12Gbps	YCbCr	4:2:2 / 4:4:4	10/12
2160p25 (3840×2160)	12G (Single Link - 2SI)	SMPTE 2082 12Gbps	YCbCr	4:2:2 / 4:4:4	10/12
2160p30 (3840×2160)	12G (Single Link - 2SI)	SMPTE 2082 12Gbps	YCbCr	4:2:2 / 4:4:4	10/12
2160p24 (4096×2160)	12G (Single Link - 2SI)	SMPTE 2082 12Gbps	YCbCr	4:2:2 / 4:4:4	10/12
2160p25 (4096×2160)	12G (Single Link - 2SI)	SMPTE 2082 12Gbps	YCbCr	4:2:2 / 4:4:4	10/12
2160p30 (4096×2160)	12G (Single Link - 2SI)	SMPTE 2082 12Gbps	YCbCr	4:2:2 / 4:4:4	10/12
2160p50 (3840×2160)	12G (Single Link - 2SI)	SMPTE 2082 12Gbps	YCbCr	4:2:2	10
2160p60 (3840×2160)	12G (Single Link - 2SI)	SMPTE 2082 12Gbps	YCbCr	4:2:2	10
2160p50 (4096×2160)	12G (Single Link - 2SI)	SMPTE 2082 12Gbps	YCbCr	4:2:2	10
2160p60 (4096×2160)	12G (Single Link - 2SI)	SMPTE 2082 12Gbps	YCbCr	4:2:2	10

Notes

3D formats

Standard		Resolution	V-Freq (Hz)	V-Total	H-Freq (kHz)	Dual-Pipe HDMI	Output Frame Rate (Hz)
1080p100	Frame Sequential	1920×1080	100	1125	112.5		100
1080p120	Frame Sequential	1920×1080	120	1125	135		120
WUXGA_100_RB	Frame Sequential	1920×1200	100	1258	125.72		100
1080p50	Dual Pipe	1920×1080	50	1125	56.25	○	100
1080p60	Dual Pipe	1920×1080	60	1125	67.5	○	120
WUXGA_50_RB	Dual Pipe	1920×1200	50	1258	62.86	○	100
WUXGA_60_RB	Dual Pipe	1920×1200	60	1125	74.04	○	120

Notes

Appendix B: wiring details

Signal inputs and outputs

HDMI 1 and 2

19 way type A connector

1	T.M.D.S. Data 2+ Input	11	Ground
2	Ground	12	T.M.D.S. Clock C- Input
3	T.M.D.S. Data 2- Input	13	CEC
4	T.M.D.S. Data 1+ Input	14	N.C
5	Ground	15	SCL
6	T.M.D.S. Data 1- Input	16	SDA
7	T.M.D.S. Data 0+ Input	17	Ground
8	Ground	18	P5V
9	T.M.D.S. Data 0- Input	19	HPD
10	T.M.D.S. Clock C+ Input		

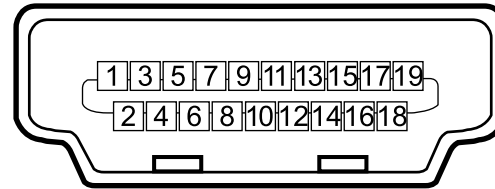

HDMI: pin view of panel connector

DisplayPort

DisplayPort 1.2

Pin 1	ML_Lane 0 (p)	Pin 11	GND
Pin 2	GND	Pin 12	ML_Lane 3 (n)
Pin 3	ML_Lane 0 (n)	Pin 13	CONFIG1
Pin 4	ML_Lane 1 (p)	Pin 14	CONFIG2
Pin 5	GND	Pin 15	AUX CH (p)
Pin 6	ML_Lane 1 (n)	Pin 16	GND
Pin 7	ML_Lane 2 (p)	Pin 17	AUX CH (n)
Pin 8	GND	Pin 18	Hot plug
Pin 9	ML_Lane 2 (n)	Pin 19	Return
Pin 10	ML_Lane 3 (p)	Pin 20	DP_PWR

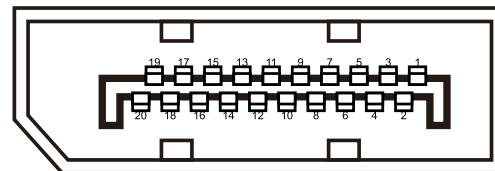

DisplayPort: pin view of panel connector

Notes

12G-SDI in, 12G-SDI out

75 ohm BNC

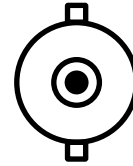

12G-SDI connector

HDBaseT input

RJ45 socket.

1	HDBT_N3
2	HDBT_P3
3	HDBT_N2
4	HDBT_N1
5	HDBT_P1
6	HDBT_P2
7	HDBT_P0
8	HDBT_N0

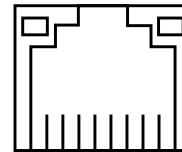

8 7 6 5 4 3 2 1

HDBaseT / LAN

Notes

Control connections

LAN

RJ45 socket (Shared with HDBaseT)

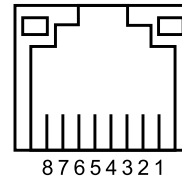

HDBaseT / LAN

RS232

9 way D-type connector

1	N.C
2	RXD
3	TXD
4	N.C
5	Ground
6	N.C
7	N.C
8	N.C
9	N.C

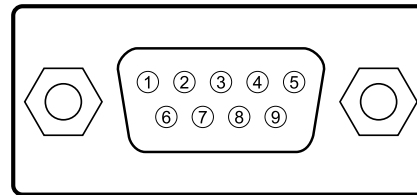

*RS232
pin view of female connector*

Wired Remote Control Input

3.5 mm mini jack

Tip	VCC(3.3V)
Sleeve-	Ground
Ring	Signal

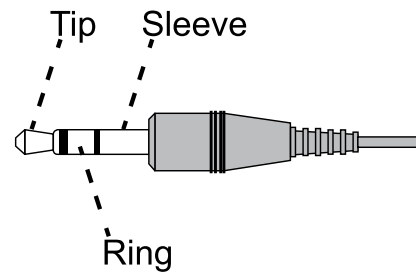

Wired Remote

Notes



Only one remote connection (RS232 or LAN) should be used at any one time.

Appendix C: memory scheme and memory items

Below is a summary of the OSD parameters that can be saved in the memory presets.

Item	Global Memory	Per Input Memory (Preset A/B/C/D)	3D input	Remark
Input Select	Ⓞ			
Test Pattern				Not Memorized
Lens Lock / Lens Memory	Ⓞ			
DB		Ⓞ		
Light Off Timer		Ⓞ		Available when DB is set at ON
Brightness		Ⓞ	N/A	
Contrast		Ⓞ	N/A	
Gamma		Ⓞ		Will apply the general gamma when HDR is not activated.
HDR Mode		Ⓞ		Will apply the gamma for HDR when auto detected the HDR signal or manual select the PQ- 400/PQ-500/PQ-1000/HLG option.
Saturation		Ⓞ	N/A	
Hue		Ⓞ	N/A	
Sharpness		Ⓞ	N/A	
Noise Reduction		Ⓞ	N/A	
Freeze			N/A	Not Memorized
Ambient Brightness Correction	Ⓞ		N/A	
Color Space		Ⓞ	N/A	
Color Mode		Ⓞ		
ColorMax		Ⓞ		When Color Mode is selected at ColorMax option.
Manual Color Matching		Ⓞ		When non-HDR and the Color Mode is selected at Manual Color Matching option.

Notes

Item	Global Memory	Per Input Memory (Preset A/B/C/D)	3D input	Remark
Matching		⊙		When HDR and the Color Mode is selected at Manual Color Matching option.
Color Temperature		⊙		When Color Mode is selected at Color Temperature option.
Red Lift		⊙		When Color Mode is selected at Gains and Lifts option.
Green Lift		⊙		
Blue Lift		⊙		
Red Gain		⊙		
Green Gain		⊙		
Blue Gain		⊙		
Aspect ratio		⊙	N/A	
Digi Zoom			N/A	Not Memorized and reset to 0 after power cycle
Digi Pan			N/A	
Digi Scan			N/A	
OverScan		⊙	N/A	
Warping Mode	⊙			All Geometry/Edge-Blending settings are global
H Keystone	⊙			
V Keystone	⊙			
Rotation	⊙			
Lens Throw Ratio	⊙			
H PinBarrel	⊙			
V PinBarrel	⊙			
4Corner	⊙			
Blanking	⊙			
Customer Warp	⊙			

Notes

Item	Global Memory	Per Input Memory (Preset A/B/C/D)	3D input	Remark	Notes
Edge Blending	⊙				
Black Level	⊙				
3D Format		⊙			
3D Sync		⊙			
3D DarkTime		⊙			
3D SyncOffset		⊙			
3D SyncReference		⊙			
Laser Mode	⊙				
Laser Power	⊙				
Fan Altitude	⊙				
Contrast Brightness	⊙				
MUBC	⊙				
Orientation	⊙				
High Altitude	⊙				
Screen Setting	⊙		N/A		
Auto Power off	⊙				
Auto Power on	⊙				
Schedule Setting	⊙				
Startup Logo	⊙				
Blank Screen	⊙				
Trig	⊙		N/A		
Auto Source	⊙		N/A		
PIC MUTE Setting	⊙				

Item	Global Memory	Per Input Memory (Preset A/B/C/D)	3D input	Remark
Ir Enable	⊙			
Ir Code	⊙			
OSD Language	⊙			
OSD Menupos	⊙			
OSD Trans	⊙			
OSD Timer	⊙			
Standby Power	⊙			
Instant Startup	⊙			
Standby Period	⊙			
EDID Mode	⊙			
Hotkey Setting	⊙			
Keypad Backlight	⊙			
Smear Reduction	⊙			
Output Frame Rate	⊙		N/A	
Lan DHCP	⊙			
Lan IP	⊙			
Lan Subnet	⊙			
Lan Gateway	⊙			
Lan DNS	⊙			
Lan MAC	⊙			
Lan AMX	⊙			
Art-Net Setting	⊙			

Notes

Appendix D: glossary of terms

Notes

1

1080p

An HDTV resolution which corresponds to 1920 x 1080 pixels (a widescreen aspect ratio of 16:9).

3

3D active glasses

Wireless battery-powered glasses with LCD shutters. Synchronization information is communicated to the glasses by means of an infrared (IR) or radio frequency (RF) emitter which is connected to the Sync Out terminal on the projector. IR or RF pulses are transmitted by the emitter to signal when the left eye and right eye images are being displayed. The glasses incorporate a sensor which detects the emitter's signal and synchronises the left and right eye shutters with the projected image.

3D passive glasses

Passive glasses do not require a power source to work. Light with left-hand polarisation can pass through the left lens and light with right hand polarisation can pass through the right-hand lens. These glasses are used in conjunction with another device which polarizes the image, such as a ZScreen.

4

4K-UHD

The 4K-UHD resolution of 3840 × 2160 is the dominant 4K resolution used in the consumer media and display industries. This resolution has an aspect ratio of 16:9, with 8,294,400 total pixels.

4K+

The 4K+ resolution of 3840 x 2400 is the dominant 4K resolution used in the consumer media and display industries. This resolution has an aspect ratio of 16:10, with 9,216,000 total pixels.

A

Adjust lines

A pattern applied to the image where its edge is to be blended with another image. Adjust lines are used to position the projectors in the array during the edge blend process.

Anamorphic lens

A special lens which, when used with the TheaterScope aspect ratio, allows watching 2.35:1 content packed in a 16:9 source.

Aperture

The opening of the lens that determines the angle through which light travels to come into focus.

Aspect ratio

The proportional relationship between the width and the height of the projected image. It is represented by two numbers separated by a colon, indicating the ratio of image width and height respectively: for example, 16:9 or 2.35:1. Not to be confused with resolution.

B**Blanking (projection)**

The ability to intentionally turn off, that is, set to black, areas around the edges of the projected image. It is sometimes referred to as “curtains” since it can be used to blank an area of image that literally falls on the curtains at the side of the screen in a movie theater. Usually no image resizing or geometric correction takes place and the “blanked” part of the image is lost. Not to be confused with horizontal and vertical blanking (video signal).

Blanking (video signal)

The section of the video signal where there is no active video data. Not to be confused with blanking (projection).

Blend region

The area of the image that is to overlap with another image in an edge blend setup. Sometimes called overlapping region.

Brightness (electronic control)

A control which adds a fixed intensity value to every pixel in the display, moving the entire range of displayed intensities up or down, and is used to set the black point in the image (see Contrast). In Component Video signals, brightness is the same as luminance.

Brightness (optical)

Describes how ‘bright’ an image that is projected onto a screen appears to an observer.

C**c**

Also known as ‘C’, this is the component, or pair of components, of a Component Video signal which describes color difference information.

Notes

Chrominance

Also known as 'C', this is the component, or pair of components, of a Component Video signal which describes color difference information.

Color difference

In Component Video signals, the difference between specified colors and the luminance component. Color difference is zero for monochrome images.

Color gamut

The spectrum of color available to be displayed.

Color temperature

The position along the black body curve on the chromaticity diagram, normally quoted in Kelvin. It takes into account the preset values for color balance in the service set-up to take up the variations in the prism. The projector allows you to adjust this temperature (i.e. adjust the picture color temperature).

Component video

A three-wire or four-wire video interface that carries the signal split into its basic RGB components or luminance (brightness) and two-color difference signals (YUV) and synchronization signals.

Contrast (electronic control)

The adjustment of the white point of the image without affecting the black point. This increases the intensity range of the displayed image.

Contrast (electronic control)

The adjustment of the white point of the image without affecting the black point. This increases the intensity range of the displayed image.

Contrast (optical)

The intensity difference between the darkest and lightest areas of the screen.

Cr, Cb

Color difference signals used with 'Y' for digital Component Video inputs. They provide information about the signal color. Not to be confused with Pr, Pb.

Crop

Remove part of the projected image. Alternatively, fit an image into a frame with a different aspect ratio by removing part of the image. The image is resized so that either its length or its width equals the length or width of the frame, while the other dimension has moved outside the frame; the excess area is then cut out.

Notes

D

Dark time

The time inserted between frames when using 3D active glasses, to avoid ghosting caused by switching time between left and right eye.

DDC (Display Data Channel)

A communications link between the source and projector. DDC is used on the HDMI, DVI and VGA inputs. The link is used by the source to read the EDID stored in the projector.

Deinterlacing

The process of converting interlaced video signals into progressive ones.

DHCP (Dynamic Host Configuration Protocol)

A network protocol that is used to configure network devices so that they can communicate on an IP network, for example by allocating an IP address.

DMD™ (Digital Micromirror Device™)

The optical tool that transforms the electronic signal from the input source into an optical image projected on the screen. The DMD™ of a projector has a fixed resolution, which affects the aspect ratio of the projected image. A Digital Micromirror Device™ (DMD™) consists of moving microscopic mirrors.

Each mirror, which acts as a pixel, is suspended between two posts by a thin torsion hinge. It can be tilted to produce either a bright or dark pixel.

E

Edge blend

A method of creating a combined image by blending the adjoining edges of two or more individual images.

Edge tear

An artifact observed in interlaced video where the screen appears to be split horizontally. Edge tears appear when the video feed is out of sync with the refresh rate of the display device.

EDID (Extended Display Identification Data)

Information stored in the projector that can be read by the source. EDID is used on the HDMI, DVI and VGA inputs, allowing the source to automatically configure to the optimum display settings.

EDTV (Enhanced Definition Television)

A progressive digital television system with a lower resolution than HDTV.

Notes

F

Field

In interlaced video, a part of the image frame that is scanned separately. A field is a collection of either all the odd lines or all the even lines within the frame.

Frame

One of the many still images displayed in a sequence to create a moving picture. A frame is made of horizontal lines of pixels. For example, a 1920×1080 frame consists of 1080 lines, each containing 1920 pixels. In analog video frames are scanned one at a time (progressive scanning) or split into fields for each field to be scanned separately (interlaced video).

Frame rate

The number of frames shown per second (fps). In TV and video, a frame rate is the rate at which the display device scans the screen to “draw” the frame.

Frame rate multiplication

To stop low frame rate 3D images from flickering, frame rate multiplication can be used, which increases the displayed frame rate by two or three times

G

Gamma

A nonlinear operation used to code and decode luminance. It originates from the Cathode Ray Tube technology used in legacy television sets.

Ghosting

An artifact in 3D image viewing. Ghosting occurs when an image intended for one eye is partially seen by the other eye. Ghosting can be removed by optimizing the dark time and sync delay.

H

HDCP (High-bandwidth Digital Content Protection)

An encryption scheme used to protect video content.

HDTV (High Definition Television)

A television system with a higher resolution than SDTV and EDTV. It can be transmitted in various formats, notably 1080p and 720p.

Notes

Hertz (Hz)

Cycles per second.

Horizontal Scan Rate

The rate at which the lines of the incoming signal are refreshed. The rate is set by the horizontal synchronization from the source and measured in Hertz.

Hs + Vs

Horizontal and vertical synchronization.

Hue

The gradation (red/green balance) of color (applicable to NTSC).

I

Interlacing

A method of updating the image. The screen is divided in two fields, one containing every odd horizontal line, the other one containing the even lines. The fields are then alternately updated. In analog TV interlacing was commonly used as a way of doubling the refresh rate without consuming extra bandwidth.

Interleaving

The alternation between left and right eye images when displaying 3D.

L

LED (Light Emitting Diode)

An electronic component that emits light.

Letterboxing

Black margins at the top and bottom of the image. Letterboxing appears when a wider image is packed into a narrower frame without changing the original aspect ratio.

Lumen

A photometric unit of radiant power. For projectors, it is normally used to specify the total amount of emitted visible light.

Luminance

Also known as 'Y'; this is the part of a Component Video signal which affects the brightness, i.e. the black and white part.

Notes

N

Noise

Electrical interference displayed on the screen.

NTSC (National Television Standards Committee)

The United States standard for television - 525 lines transmitted at 60 interlaced fields per second

O

OSD (on-screen display)

The projector menus allowing you to adjust various settings.

Overlapping region

The area of the image that is to overlap with another image in an edge blend setup. Sometimes called overlapping region.

P

PAL (Phase Alternate Line)

The television system used in the UK, Australia and other countries - 625 lines transmitted at 50 interlaced fields per second.

Pillarboxing

Black margins at the left and right of the image. Pillarboxing appears when a narrower image is packed into a wider frame without changing the aspect ratio.

Pixel

Short for Picture Element. The most basic unit of an image. Pixels are arranged in lines and columns. Each pixel corresponds to a micromirror within the DMD™; resolutions reflect the number of pixels per line by the number of lines. For example, a 1080p projector contains 1080 lines, each consisting of 1920 pixels.

Pond of mirrors

Area around the periphery of the DMD™ containing inactive mirrors. The pond of mirrors may cause artifacts, for example during the edge blending process.

Pr, Pb

Color difference signals used with 'Y' for analog Component Video inputs. They provide information about the signal color. Not to be confused with Cr, Cb

Notes

Primary colors

Three colors any two of which cannot be mixed to produce the third. In additive color television systems the primary colors are red, green and blue.

Progressive scanning

A method of updating the image in which the lines of each frame are drawn in a sequence, without interlacing.

Pulldown

The process of converting a 24 fps film footage to a video frame rate (25 fps for PAL/SECAM, 30 fps for NTSC) by adding extra frames. DP projectors automatically carry out reverse pulldown whenever possible.

R

Resolution

The number of pixels in an image, usually represented by the number of pixels per line and the number of lines (for example, 1920 x 1200).

RGB (Red, Green and Blue)

An uncompressed Component Video standard.

S

Saturation

The amount of color in an image.

Scope

An aspect ratio of 2.35:1.

SDTV (Standard Definition Television)

An interlaced television system with a lower resolution than HDTV. For PAL and SECAM signals, the resolution is 576i; for NTSC it is 480i.

SECAM (Sequential Color with Memory)

The television system used in France, Russia and some other countries - 625 lines transmitted at 50 interlaced fields per second.

Smooth picture

A feature that can display a higher resolution source than the native resolution of the projector without losing any pixel data.

Notes

SX+

A display resolution of 1400 x 1050 pixels with a 4:3 screen aspect ratio. (Shortened from SXGA+, stands for Super Extended Graphics Array Plus.)

Synchronization

A timing signal used to coordinate an action.

T

Test pattern

A still image specially prepared for testing a projection system. It may contain various combinations of colors, lines and geometric shapes.

TheaterScope

An aspect ratio used in conjunction with a special anamorphic lens to display 2.35:1 images packed into a 16:9 frame.

Throw distance

The distance between the screen and the projector.

Throw ratio

The ratio of the throw distance to the screen width.

TRC (Throw ratio correction)

A special number used in calculating throw distances and throw ratios when the image does not fill the width of the DMD™. TRC is the ratio of the DMD™ aspect ratio to the image source aspect ratio: $TRC = \text{DMD}^{\text{TM}} \text{ aspect ratio} / \text{Source aspect ratio}$ TRC is only used in calculations if it is greater than 1.

U

UXGA

A display resolution of 1600 x 1200 pixels with a 4:3 screen aspect ratio. (Stands for Ultra Extended Graphics Array.)

Notes

V

Vertical Scan Rate

The rate at which the frames of the incoming signal are refreshed. The rate is set by the vertical synchronization from the source and measured in Hertz.

Vignetting

Optical cropping of the image caused by the components in the projection lens. This can happen if too much offset is applied when positioning the image using the lens mount.

Vista

An aspect ratio of 1.66:1.

W

WUXGA

A display resolution of 1920 x 1200 pixels with a 16:10 screen aspect ratio. (Stands for Widescreen Ultra Extended Graphics Array.)

Y

Y

This is the luminance input (brightness) from a Component Video signal.

YUV

Color difference signals used with 'Y' for analog Component Video inputs. They provide information about the signal color. Not to be confused with Cr, Cb.

Z

ZScreen

A special kind of light modulator which polarizes the projected image for 3D viewing. It normally requires that images are projected onto a silver screen. The ZScreen is placed between the projector lens and screen. It changes the polarization of the projected light and switches between left- and right- handed circularly polarized light at the field rate.

Notes

DIGITAL PROJECTION

A brand of  DELTA

Contact Information:

Europe

Digital Projection Limited

Unit 3 Aniseed Park,
Broadgate, Oldham,
OL9 9XA, United Kingdom

Registered in England No.
03287264

Registered Office: As Above

Tel: (+44) 161 947 3300
Fax: (+44) 161 684 7674

enquiries@digitalprojection.co.uk

service@digitalprojection.co.uk

www.digitalprojection.co.uk

North America

Digital Projection Inc.

55 Chastain Road, Suite 115,
Kennesaw, GA 30144, USA

Tel: (+1) 770 420 1350

Fax: (+1) 770 420 1360

powerinfo@digitalprojection.com

www.digitalprojection.com

China

Digital Projection China

中国 北京市 朝阳区 芍药居北里
101号

世奥国际中心A座2301室(100029)

Rm A2301, ShaoYaoJu 101
North Lane, Shi Ao International
Center, Chaoyang District, Beijing
100029, PR CHINA

Tel: (+86) 10 84888566

Fax: (+86) 10 84888566-805

techsupport@dp-china.com.cn

www.dp-china.com.cn

Japan

Digital Projection Japan

〒105-0012 東京都港区芝大門
2-1-14

2-1-14 Shibadaimon, Minato-ku,
Tokyo, Japan 105-0012

japan@digitalprojection.co.uk

www.digitalprojection.com/ja

Taiwan

Digital Projection Taiwan

186 Ruey Kuang Rd, Neihu
District, Taipei, 114 Taiwan

Tel: +886-8797-2088 x8854

Taiwan@digitalprojection.co.uk

Korea

Digital Projection Korea

대한민국 서울 금천구 가산디지털1로
219, 벽산 디지털 벨리 6차 1511

1511, Byucksan Digital Valley
6-cha, 219 Gasan Digital 1-ro,
Geumcheon-gu, Seoul, Korea

Tel: (+82) 2 515 5303 #1225

Korea@digitalprojection.co.uk

www.digitalprojection.com/ko

India

Digital Projection India

Plot-43, Sector-35, HSII DC,
Gurgaon Haryana -122001

Tel: +91-124-4874900#4275

india@digitalprojection.co.uk

"Importer for EU
statement per REGULATION (EU)
2023/988"

Top Group International B.V.

Perryweg 2-8
3225Kg Hellevoetsluis
The Netherlands

Tel. +31 418 66 66 88

sally@topgroup.nl